

Linear modules MKK, MKR, MLR

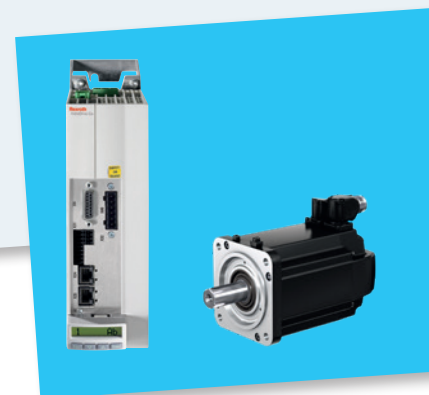
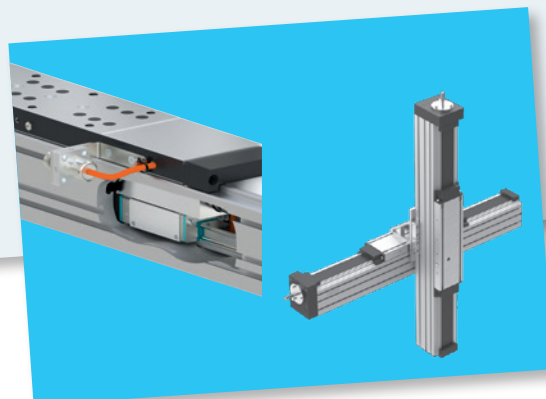
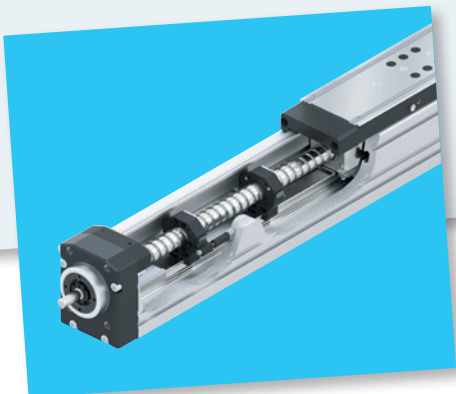
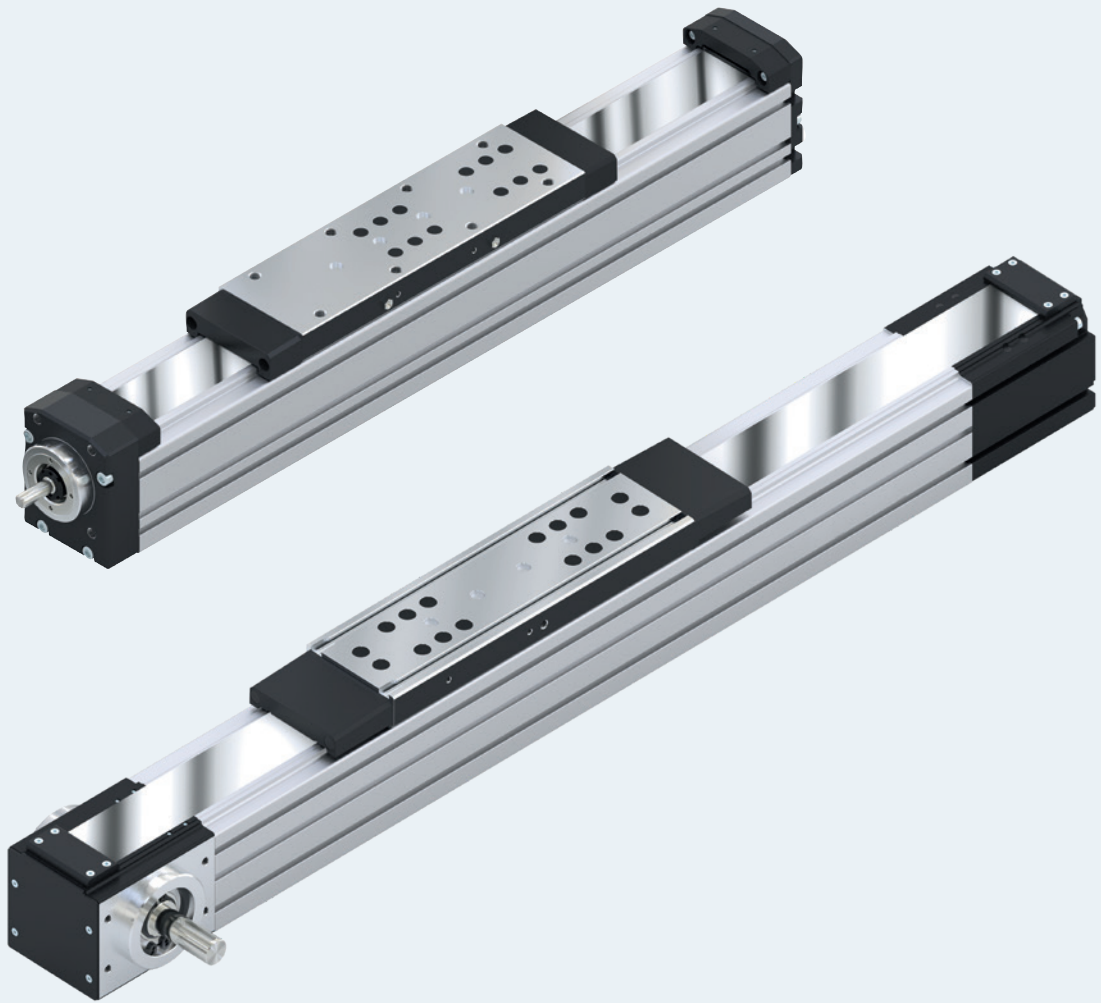

Overview

Rexroth linear modules

Identification system for short product names

Example		M	K	K	- 110 -	NN	- 3
System	= Linear M odule						
Guideway	= Ball rail system (BSHP) (K) = Cam roller guide (L)						
Drive	= Ball screw assembly (K) = Belt drive (R)						
Size	= 040 / 065 / 080 / 110 / 140 / 145 / 165						
Version	= NN -Normal version						
Generation	= Product generation 2/3						

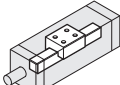
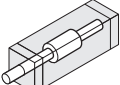
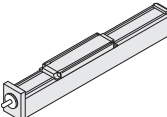
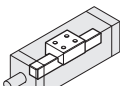
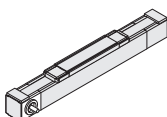
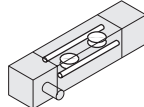
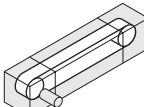
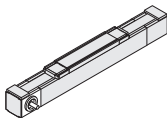
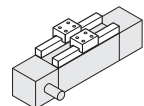
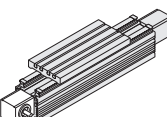
Type	Guideway	Drive	Linear module
MKK	 Ball rail system (K)	 Ball screw assembly (K)	
MKR	 Ball rail system (K)		
MLR	 Cam roller guide (L)	 Belt drive (R)	
MKR-145	 two ball rail systems (K)		

Changes/additions at a glance

Changes as compared to edition 2021-03

- ▶ MS2N motors revised: chapter "Configuration and ordering" and chapter "Motors"
- ▶ "Automation package" amended: in the product description, in the option tables, for accessories
- ▶ Revision "Technical data" (load capacities and moments)
- ▶ Section "Threaded strips" in the Attachments and accessories chapter revised

Product generations

Product generation 2 (only size -165)

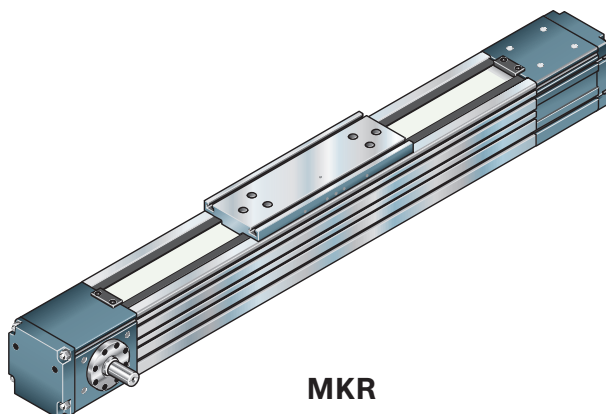
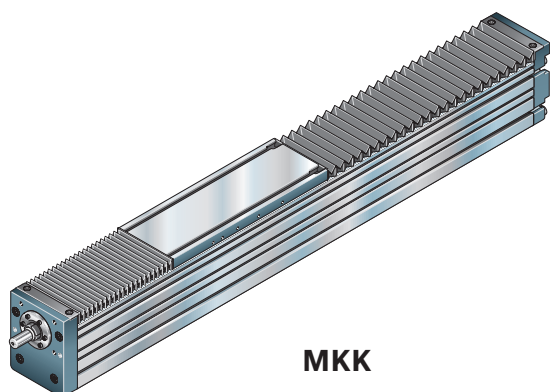

Product generation 3

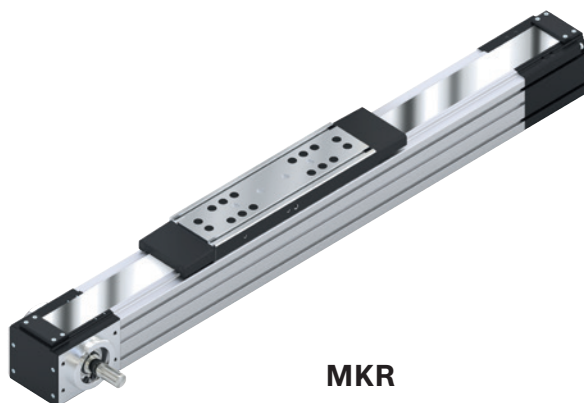
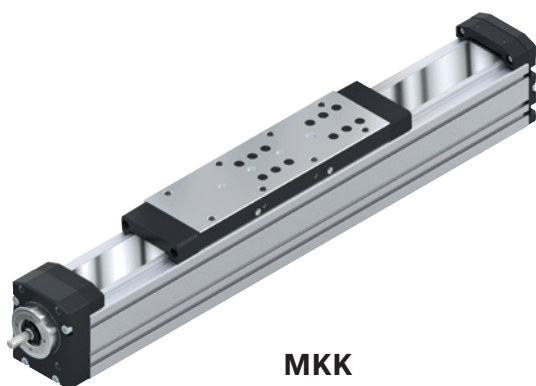

Linear module	Size	Product generation 2	Product generation 3 (new)
MKK - / MKR - NN	-040	Replaced by generation 3	MKx-040-NN-3
	-065	Replaced by generation 3	MKx-065-NN-3
	-080	Replaced by generation 3	MKx-080-NN-3
	-110	Replaced by generation 3	MKx-110-NN-3
	-140	–	MKx-140-NN-3
	-165	MKx-165-NN-2	–
	-145 (MKR only)	Replaced by generation 3	MKR-145-NN-3
MLR - NN	-080	Replaced by generation 3	MLR-080-NN-3
	-110	Replaced by generation 3	MLR-110-NN-3

MKx: x = K for ball screw assembly, x = R for toothed belt drive

General product description MKK/MKR/MLR/OBB	6	Dimension drawings	113
Linear modules delivery form	10	Nozzle pipe	114
Linear modules MKK	14	Frequency meter	114
Product description MKK-xxx-NN-3	14	Linear motion systems connection technology	115
Product description MKK-165-NN-2	17	Product description	115
Structural design	18	Motors	116
Technical data	20	Motor attachment kits according to customer specification	116
Configuration and ordering	32	IndraDyn S - Servo motors MSM	118
MKK-040-NN-3	32	IndraDyn S - Servo motors MS2N	120
MKK-065-NN-3	34	Automation package	122
MKK-080-NN-3	36	Motor/controller combinations	123
MKK-110-NN-3	38	Motor/controller/cable combinations	126
MKK-140-NN-3	40	Type designation	130
MKK-165-NN-2	42	Switching system MKK, MKR, MLR	134
Dimension drawings	44	Overview of switching system	134
MKK-040/-065/-080/-110/-140/-NN-3	44	Switch mounting arrangement	
MKK-165-NN-2	50	MKK/MKR-040-NN-3	134
Linear modules MKR	52	Switch mounting arrangement	
Product description MKR-xxx-NN-3	52	MKK/MKR -065/-080/-110/-140-NN-3	136
Product description MKR-165-NN-2	54	Switch mounting arrangement	
Structural design	55	MLR-080/-110-NN-3	136
Technical data	56	Switch mounting arrangement MKR-145-NN-3	137
Configuration and ordering	64	Inductive sensors, mechanical switches and accessories (MKK/MKR/MLR)	138
MKR-040-NN-3	64	Mounting examples of switches	139
MKR-065-NN-3	66	Switch mounting	140
MKR-080-NN-3	68	Socket and connector, cable duct	142
MKR-110-NN-3	70	Switch system accessories	144
MKR-140-NN-3	72	Sensors	144
MKR-165-NN-2	74	Switches	150
Dimension drawings	76	Extensions	154
MKR-040/-065/-080/-110/-140/-NN-3	76	Connectors	156
MKR-165-NN-2	82	Adapters	157
Linear modules MKR-xxx-NN-3 without drive / support axle	84	Distributors	158
Linear modules MLR	86	Combination examples	162
Product description MLR-xxx-NN-3	86	Integrated measuring system IMS-A	164
Structural design	87	Additional information	166
Technical data	88	Operating conditions	166
Configuration and ordering	92	Lubrication-MKx-165-NN-2	167
MLR-080-NN-3	92	Lubrication-MLR-xxx-NN-3	167
MLR-110-NN-3	94	Lubrication MKx-xxx-NN-3	168
Dimension drawings MLR-080/-110/-NN-3	96	Documentation	170
Linear modules MKR-145	100	Parameterization (commissioning)	172
Product description MKR-145-NN-3	100	Project planning/calculation	174
Structural design	101	Calculation principles	174
Technical data	102	Calculation example MKK with belt side drive	184
MKR-145-NN-3	104	Calculation example MKR with gear reducer	187
MKR-145-NN-3 dimension drawings	106	Abbreviations	190
Attachments and accessories	108	Ordering example MKK-080-NN-3	192
Fastener	108	Further information	193
Mounting and fastening elements	110	Notes	194
Connecting shafts	112		

General product description

Product description MKK/MKR/MLR-xxx-NN-3

The new product generation 3 (MKK/MKR/MLR-XXX-NN-3) of the Rexroth linear modules is based on the consistent further development of the previous series. The usual Rexroth performance features have been enhanced once again in terms of backward compatibility.

Linear modules are available complete with motors, controllers and control units.

Structural design

- Ready-to-install linear modules in any length up to L_{max}
- Extremely compact aluminum profile with integrated Rexroth ball rail systems (MKK/MKR) or cam roller guides (MLR)
- Identical exterior profile dimensions between linear modules MKK, MKR, MLR
- Various carriage versions.
- Individual lubrication versions for connection to central lubrication systems

Attachments (range of accessories)

- Sensors and extension cables
- Switches (proximity or mechanical)
- Switching cam
- Socket and connector
- Aluminum profile cable duct
- Clamping fixtures and sliding blocks
- Connecting shafts
- Linear motion systems connection technology

Further highlights

- Flexible thanks to selectable options
- Centering holes for simple combination with other linear systems and connection elements
- MKK/MKR available in two material pairings ALST (aluminum/steel version) and ALCR (aluminum/steel hard chrome plated version).
- Optionally selectable absolute length measuring system IMS-A (MKx-080/-110/-140)
- Magnetic field sensors can be mounted in frame/profile slot
- Motor attachment via flange and coupling or via timing belt side drive
- Planetary gear with various gear ratios
- Servo motor

Application areas

- Pick and place
- Handling systems
- Placement systems, palletizers
- Machine tool feed units
- Inspection and analysis systems
- Feed units in transfer lines
- Motion units

Linear module MKK with ball rail system and ball screw assembly

- Drive via precision ball screw assembly, either in accuracy class T7 or T5
- Screw support (only suitable for horizontal installation position) to reach high speeds with large overall lengths (MKK-080/ -110/-140) optionally available.
- Installation elements are protected by a plastic strip (MKK-040 / -065) or corrosion-resistant steel strip (MKK-080/-110/-140)
- Repeatability of up to +/- 0.005 mm

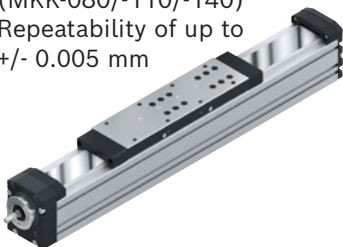

Linear module MKR with a ball rail system and belt drive

- Realization of greater lengths of up to 9800 mm
- High-performance toothed belt (AT profile) for high travel speeds of up to 5 m/s
- Installation elements are protected by a plastic strip (MKR-040/-065) or corrosion-resistant steel strip (MKR-080/-110/-140)
- Repeatability of up to +/- 0.05 mm



Linear module MLR with cam roller guide and toothed belt drive

- Realization of greater lengths of up to 10000 mm
- High-performance toothed belt (AT profile) for high travel speeds of up to 10 m/s
- Installation elements are protected by a toothed belt
- Repeatability of up to +/- 0.05 mm



Product description MKK/MKR-165-NN-2

Rexroth linear modules of product generation 2 (MKx-165-NN-2) are precise, ready-to-install guide systems with high-performance features in compact dimensions.

Linear modules are available complete with motors, controllers and control units.

Structural design

- Ready-to-install linear modules in any length up to L_{max}
- Extremely compact aluminum profile with integrated Rexroth ball rail systems
- Identical exterior profile dimensions between linear module types MKK and MKR
- Aluminum carriages with T-slots

Attachments

- Switches (proximity or mechanical)
- Socket and connector
- Aluminum profile cable duct

Attachments (range of accessories)

- Clamping fixtures and sliding blocks
- Connecting shafts
- Linear motion systems connection technology
- Sensors and extension cables

Further highlights

- Flexible thanks to selectable options
- Central re-lubrication point of the Rexroth ball rail system and the Rexroth precision ball screw assembly (MKK) from both sides; lubrication only suitable for grease lubrication with a manual grease gun.
- With bellows cover on MKK-165
- Motor attachment via flange and coupling or via timing belt side drive
- Planetary gear with various gear ratios
- Servo motor

Application areas

- Pick and place
- Handling systems
- Placement systems, palletizers
- Machine tool feed units
- Inspection and analysis systems
- Feed units in transfer lines
- Motion units

Linear module MKK with ball rail system and ball screw assembly

- Drive via precision ball screw assembly, accuracy class T7
- Installation elements are protected by a bellows cover
- Repeatability of up to ± 0.005 mm

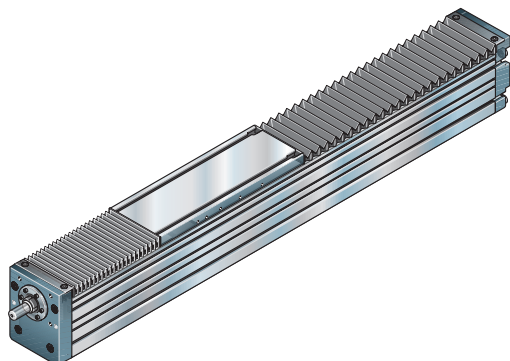

Linear module MKR with a ball rail system and toothed belt drive

- Realization of greater lengths of up to 12000 mm
- High performance toothed belt (AT profile) for high travel speeds of up to 5 m/s
- Repeatability of up to ± 0.05 mm

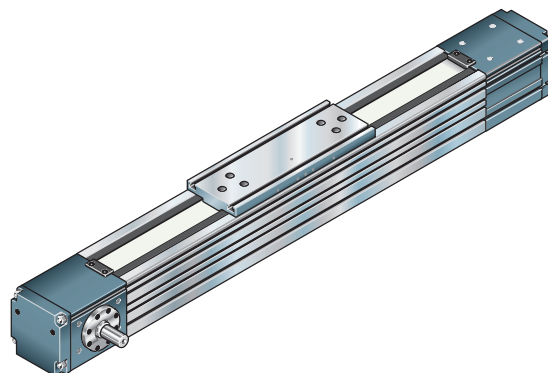

General product description

Product description MKR-145-NN-3

Rexroth linear modules are precise, ready-to-install guide systems that combine high-performance characteristics with compact dimensions. Rexroth provides a favorable price/performance ratio and fast delivery times.

Linear modules are available complete with motors, controllers and control units.

Structural design

- Ready-to-install linear modules in any length up to L_{\max}
- Realization of greater lengths of up to 6000 mm
- Rigid aluminum profile frame with Rexroth ball rail system with cover strip
- Ball runner block with moderate preload (Preload class C1)
- Aluminum carriages with T-slots and centering holes
- Economical maintenance thanks to the one-point lubrication feature (grease lubrication or oil lubrication) from both sides via the carriage
- High-performance toothed belt (AT profile) for high drive torques with simultaneously high rigidity

Attachments

- Planetary gear with various gear ratios
- Attachment kits for motor according to customer specification
- Servo motor
- Magnetic field sensors for easy assembly
- Switches (proximity or mechanical), cable duct,

Socket-plug and extension cables in the range of accessory products

Further highlights

- Centering holes also in the frame profile for simple combination with other linear systems and connection elements
- Standard with integrated solenoid switch for magnetic field sensors
- Extensive accessories range of connection and clamping units and connecting shafts
- Nameplate with parameters for easy commissioning

Application areas

- Pick and place
- Handling systems
- Placement systems, palletizers
- Machine tool feed units
- Feed units in transfer lines

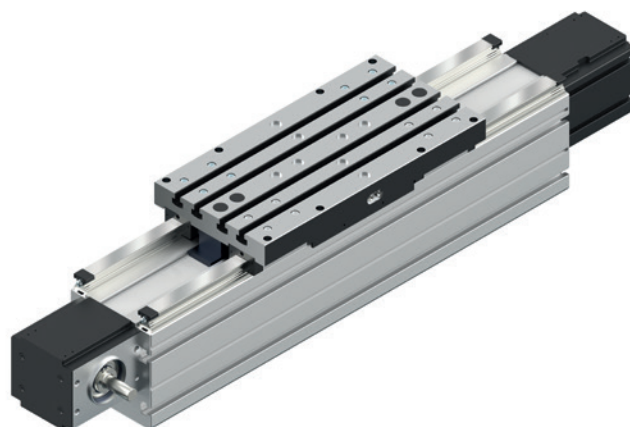

Product description – Omega modules OBB

Omega modules are ready-to-install linear axes for any installation position in freely configurable lengths of up to 5500 mm.

Omega modules (OBB) with ball rail system and toothed belt drive for speeds of up to 5.0 m/s.

Omega modules are available complete with motors, controllers and control units.

Structural design

Due to the structural design, Omega modules are particularly suited for applications where the frame extends into the working area.

- Frame from anodized aluminum frame with high inherent rigidity
- Integrated ball rail system
- Carriage from an aluminum profile with ball runner blocks
- Driven by toothed belt for travel speeds of up to 5 m/s

Attachments

- Switches (proximity and mechanical)
- Socket and connector
- Aluminum profile cable duct

For more information, see the catalog "OBB Omega modules" R999001178

Further highlights:

- The Rexroth ball rail system features one-point lubrication from both sides (only suitable for grease lubrication with a manual grease gun)
- With centering holes in the carriage and on the end blocks
- Driven by a toothed belt for high dynamics and high travel speeds
- Pneumatic clamping unit is optional
- With planetary gear (PG) or angular planetary gear (WPG) with various gear ratios
- Servo motor

Application areas

- Pick and place
- Handling systems

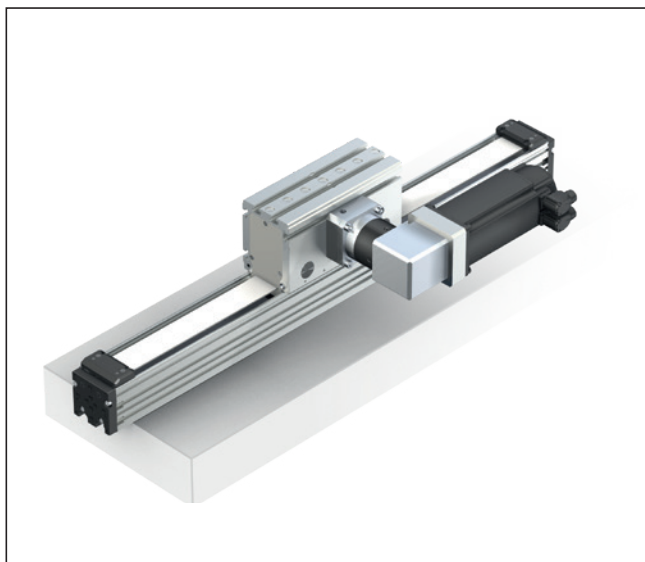

OBB as a horizontal axis

Installation case: Carriage moves
(frame fastened)

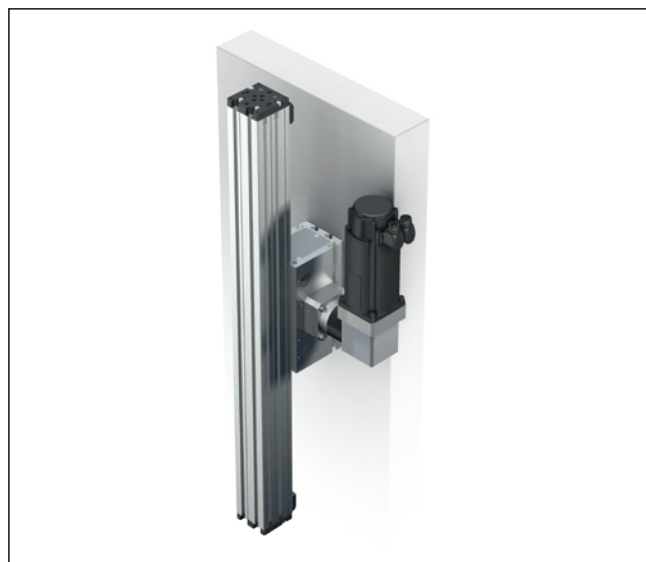

OBB as a vertical axis

Installation case: Frame moves
(fixed carriage)

General product description

Linear modules delivery form

Product generation 3:

Linear modules with ball screw or toothed belt drive are delivered fully assembled.

Gear/motor attachment interface:

If a combination of attachment interface, gears and motor has been selected, the attachment of the components is done as shown in the figure below. When ordering linear modules with only an attachment interface (without gears and motor!), not all parts can be mounted. Final assembly must then be carried out by the customer. All required instructions and parameters for professional assembly are included. The installation version is selected and determined during product configuration, and it is a part of the ordering code.

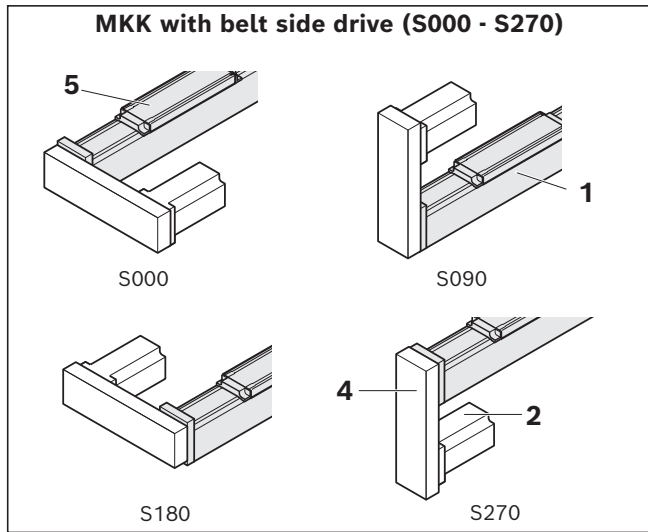
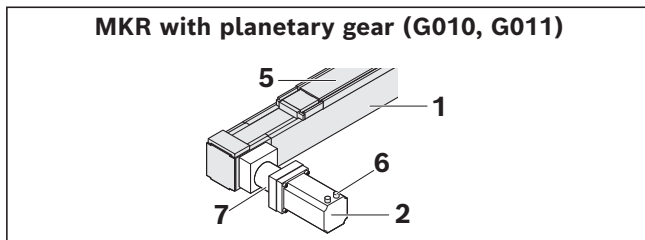
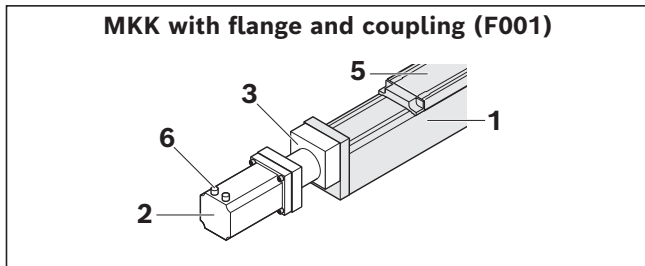

Motor connector position

- Linear module in horizontal installation position (carriage at the top)
- View toward the motor from the rear
- Selectable motor connector locations, see chapter "Configuration and ordering"

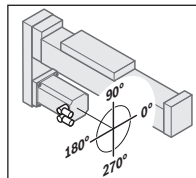

Example:
Timing belt side drive S270
Motor connector position 180°

Integrated measuring system

For further information, see the "Integrated Measuring System" chapter

Switching system

Magnetic sensors are included as loose parts. Further switching system components can be ordered from the range of accessory products. The exact setting of the position must be carried out before commissioning. See chapter "Switching system."

Lubrication

On delivery, linear modules of product generation 3 are supplied with initial greasing, preserved or prepared for connection to a central lubrication system according to the optionally selected lubricant version. Information about lubricants can be found in the chapter Lubrication.

Documentation

Each linear module is supplied with the appropriate documentation.

Product generation 2 (MKK/MKR-165-NN-2):

Linear modules with ball screw or toothed belt drive are delivered fully assembled.

Motor attachment - motor:

If a combination of motor mounting and motor has been chosen, the attachment of the components is done as shown in the figure below. When ordering linear modules only with a motor mounting (without motor!), not all parts can be mounted. Final assembly must then be carried out by the customer. All required instructions and parameters for professional assembly are included.

The installation version is selected and determined during product configuration, and it is a part of the ordering code.

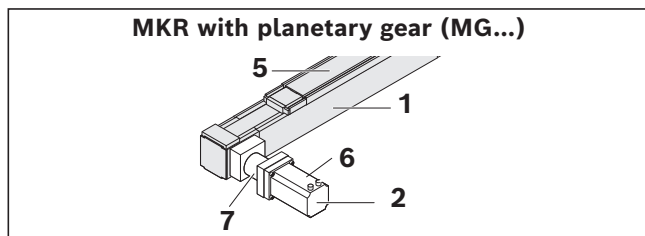
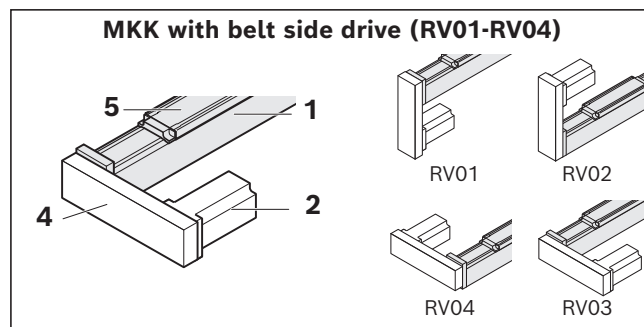
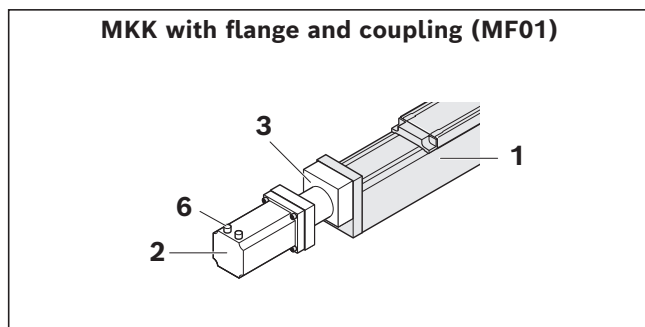

Motor connector position

An individually selectable motor connector position is not configurable for product generation 2 linear modules, therefore a standard position is specified upon delivery. Selectable motor connector positions, see chapter "Configuration and ordering."

Switching system

Cable duct, switch, switching cam and socket with connector are included as loose parts.

Lubrication

Product generation 2 linear modules are delivered with initial greasing. Information about lubricants can be found in the chapter Lubrication.

Documentation

Each linear module is supplied with the appropriate documentation.

- 1 Linear module
- 2 Motor
- 3 Flange and coupling
- 4 Belt side drive
- 5 Carriage
- 6 Motor connector
- 7 Gearing

General product description
Axis + drive + software

**SAVE TIME AND MONEY:
EVERYTHING FROM A SINGLE SOURCE.
WITH A SINGLE MATERIAL NUMBER.**

To enable you to realize fully automated movements with single axes faster, all components are now available in one package.

With just a few clicks, you can design and configure motor, drive controller, mains filter and cable online, and optionally also the software.

Ordered with just one material number, your solution will be available to you in now time – and immediately ready for operation thanks to the axis parameters stored in the motor. If necessary, the proven Rexroth service is always available to assist you.

Really everything from a single source.
Can it be easier?



The quicker way to automate:

**Single axis + drive + software
in one package.**



**3 ORDERING OPTIONS,
ALL FREEDOMS:**

1. **Single axis**
2. **Single axis + drive**
(incl. mains filter/cable)
3. **Single axis + drive + software**
(incl. mains filter/cable) as plug & play complete solution

Product description MKK-xxx-NN-3

Features

- Ready-to-install linear modules in any length up to L_{\max}
- Extremely compact aluminum profile with integrated Rexroth ball rail system.
Ball rail system with moderate preload (preload class C1)
- Driven by precision BASA ball screw drive in rolled design, optionally in tolerance grade T7 or T5 according to ISO 3408-3 with zero-backlash cylindrical single nut
- High travel speeds thanks to large leads with high precision over long distances
- Carriage made of aluminum, in two design versions, with T-slots or threaded holes and with centering holes in each case
- Protection of the guideway and drive components by sealing strip (plastic strip for MKK-040/-065, corrosion resistant steel strip for MKK-080/-110/-140)
- Economical maintenance thanks to one-point lubrication feature (grease or oil lubrication) on either one or both sides of the carriage
- Repeatability of up to ± 0.005 mm

Further highlights

- Available in two material versions, ALST (aluminum/steel version) and ALCR (aluminum/steel hard chrome plated version).
- Centering holes also in the frame for simple combination with other linear motion systems and connection elements
- Screw support (SPU) to reach high speeds with a large travel range (MKK-080/-110/-140) optionally available
- Absolute length measuring system IMS-A directly integrated into the guide system (MKK-080/-110/-140)
- Standard with integrated solenoid switch for magnetic field sensors
- Extensive accessories range of connection and clamping units
- Nameplate with parameters for easy commissioning

Attachments

- Motor attachment with flange and coupling or via a belt side drive
- Attachment kits for motor according to customer specification
- Servo motor
- Magnetic field sensors for easy assembly directly on the profile frame
- Switch (proximity or mechanical) cable duct, socket-plug and extension cable in the accessories program

Carriage with thread

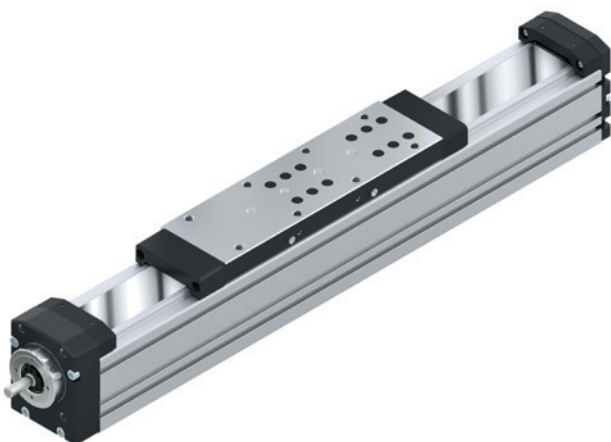

Carriage with T-slots

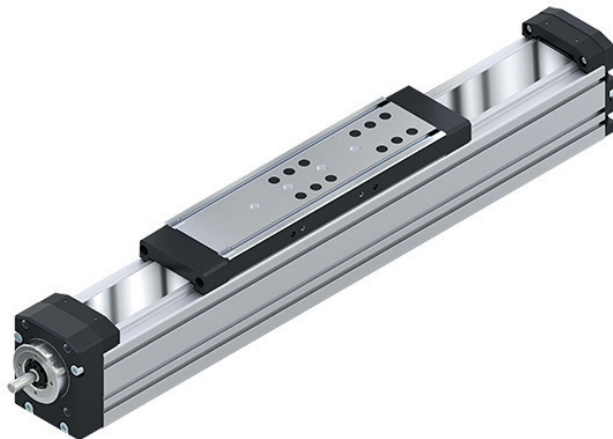

**Product description
Screw support (SPU)**

for MKK-080/-110/-140

The screw support (SPU) offers the following advantages:

- Screw support for horizontal applications (please consult us for vertical applications)
- Screw support can be selected as standard option via the option number.
- A maximum of two screw support pairs is possible.
- High speed over long lengths of up to 5400 mm.
- Guideway of the screw supports in the frame.
- Screw supports are maintenance-free.
- Screw supports are protected by optionally selectable sealing strip.

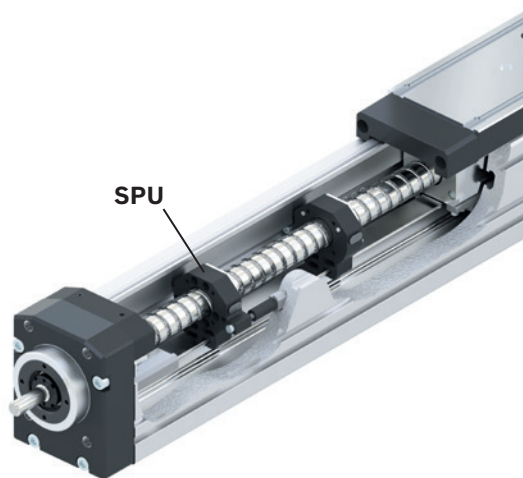

**Product description
Integrated measuring system**

for MKK-080/-110/-140

The IMS-A measuring system offers the following advantages:

- No additional space required.
- No additional mounting surfaces required for the measuring system.
- No measurement inaccuracies due to parallelism offset between the measuring system and the guide system.
- Full integration of the measuring system components into the guide means no complex mounting or tuning work is needed.
- The runner block, scanner and guide rail with scale can be replaced individually during servicing.
- Interfaces: HIPERFACE (HF) or DRIVE-CLiQ (DQ).
- Connecting cable directly on the side of the carriage.
- For further information, see the "Integrated Measuring system" chapter

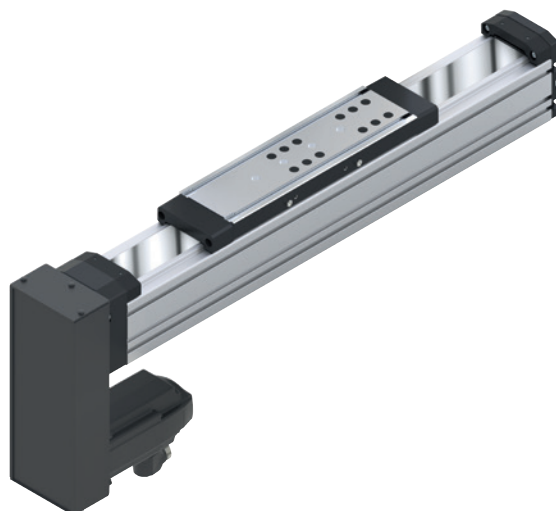
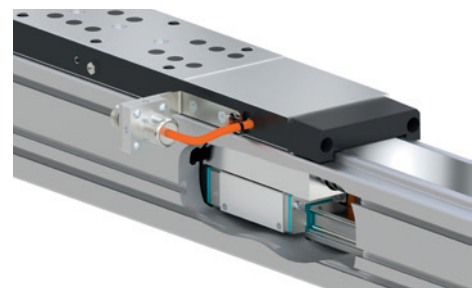

Motor attachment with belt side drive

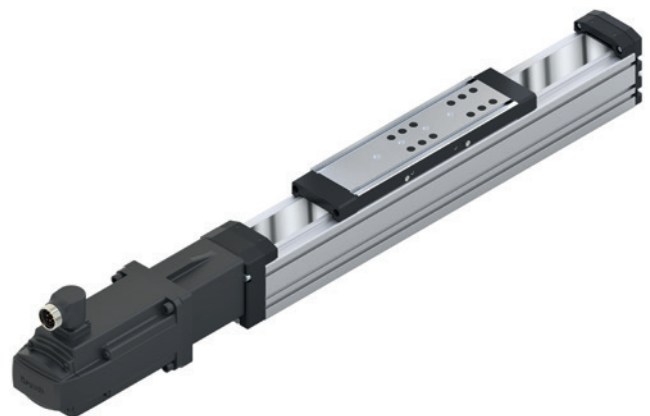

Motor attachment with flange coupling

Product description MKK-xxx-NN-3

Material pairing

ALST:

- Frame, carriage and end blocks made of anodized aluminum (AL)
- MKK-065/-080/-110/-140: ball guide rail, ball runner block and Rexroth ball screw assembly made of anti-friction bearing steel (ST)
- MKK-040: Ball guide rail and ball runner block of rust and acid resistant material. Ball screw assembly made of anti-friction bearing steel (ST)
- Angular-contact ball bearing and deep-groove ball bearing of the screw drive bearing made of anti-friction bearing steel

ALCR:

- Frame, carriage and end blocks made of anodized aluminum (AL)
- MKK-065/-080/-110/-140: Ball guide rail and Rexroth ball screw assembly made of anti-friction bearing steel with corrosion-resistant coating, matte-silver finish, hard chrome plated (Resist CR), ball runner block from corrosion-resistant steel (Resist NR)
- MKK-040: Ball guide rail and ball runner block of rust and acid resistant material. Ball screw assembly made of anti-friction bearing steel with corrosion-resistant coating, matte-silver finish, hard chrome plated (Resist CR)
- Angular-contact ball bearing and deep-groove ball bearing of the screw drive bearing made of anti-friction bearing steel

Lubrication versions

LSS: (Initial lubrication done at the factory)

- Initial standard greasing done at the factory, suitable for normal environmental conditions.
- Simple relubrication via manual grease gun.

MKK-065/-080/-110/-140:

- Grease Dynalub 510, lithium-based high-performance grease of grade NLGI 2 according to DIN 51818 (KP2K-20 according to DIN 51825)

MKK-040:

- Grease lubricant Dynalub 520, lithium-based high-performance grease of grade NLGI 00 according to DIN 51818 (GP00K-20 according to DIN 51826)

LPG: (Corrosion prevention, no initial lubrication)

- Linear module without initial greasing done at the factory.
- Ball rail system and ball screw drive only with corrosion prevention.
- Basic lubrication required

LCF: (prepared for connection to central lubrication systems with liquid grease)

- for liquid grease, lithium-based high-performance grease of grade NLGI 00 according to DIN 51818 (GP00K-20 according to DIN 51826)
- Only use liquid grease lubrication with single-line total-loss lubrication systems via piston distributors.
- Basic lubrication required

LCO: (prepared for connection to central lubrication systems with oil)

- ball runner block and ball screw assembly nut with integrated non-return valves
- Only use oil lubrication with single-line total-loss lubrication systems via piston distributors.
- Basic lubrication required

Product description MKK-165-NN-2

Features

Linear modules with ball rail system and ball screw assembly for high positioning accuracy and repeatability as well as thrust forces.

The Linear modules comprise:

- A compact, anodized aluminum profile (frame)
- The integrated Rexroth ball rail system
- A carriage with T-slots for fixtures, with central lubrication point
- The Rexroth ball screw assembly set to zero-clearance (also available without a drive)
- Mountable switches
- Servo motor
- Flange, coupling or timing belt side drive for motor attachment
- Cover provided by the bellows

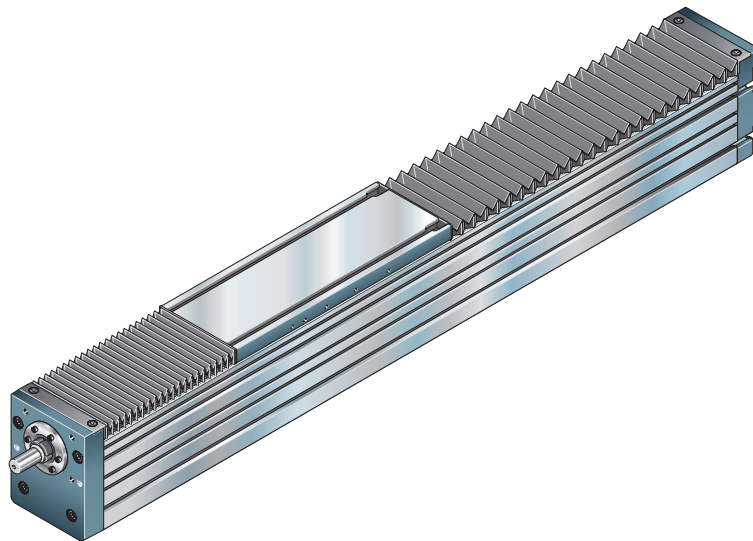

Linear modules MKK

Structural design

- 1 BASA ball screw drive with zero-backlash cylindrical single nut
- 2 End block fixed bearing
- 3 Sealing strip on MKK-040/-065/-080/-110/-140
- 4 Carriage with runner block
- 5 Strip fixing
- 6 End block floating bearing
- 7 Frame

Attachments:

- 8 Switching cam
- 9 Proximity switch
- 10 Mechanical switch
- 11 Cable duct
- 12 Socket/connector
- 13 Bellows cover for MKK-165
- 14 Magnetic field sensor

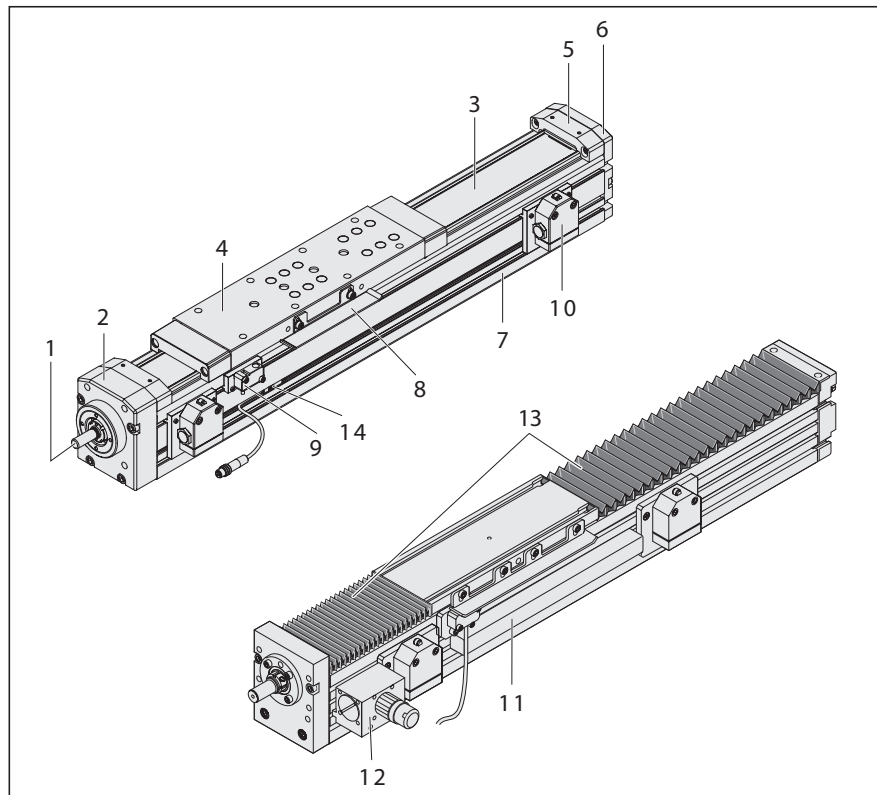

- 15 Flange
- 16 Servo motor
- 17 Belt side drive

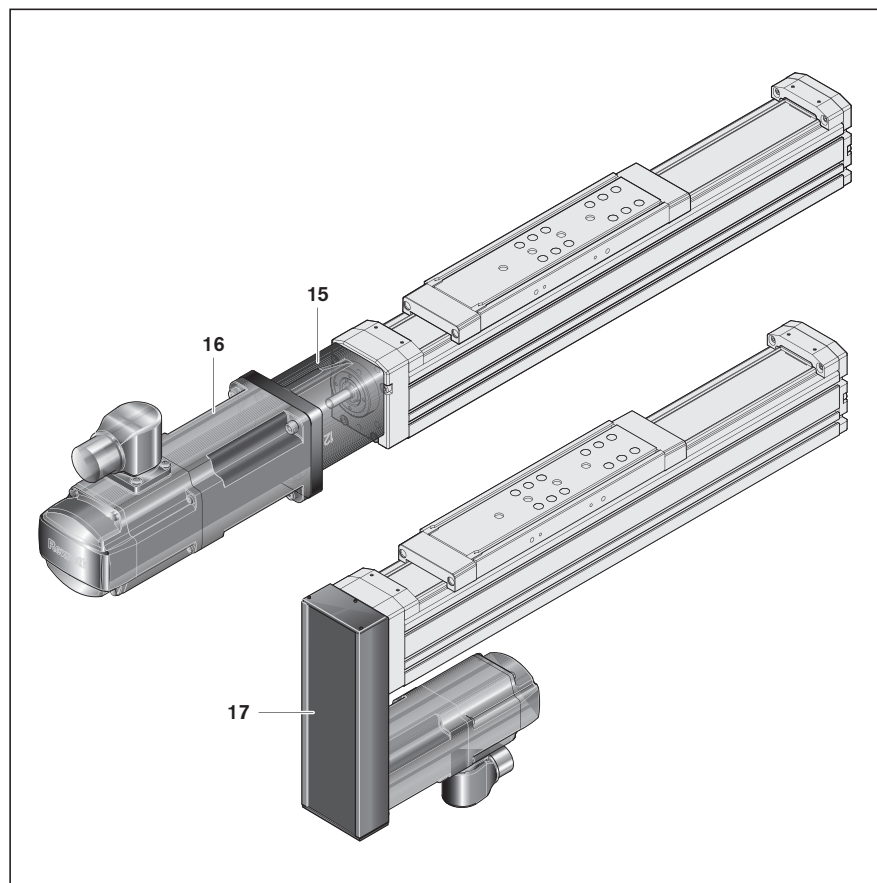

Structure of flange and coupling

All linear module with a ball screw assembly allow for the attachment of a motor via a flange and coupling.

The flange serves to fasten the motor to the linear module and acts as a closed housing for the coupling. The coupling transmits the motor drive torque free of distortive stresses to the linear module's drive shaft.

Our standard couplings compensate for the system's thermal expansion.

- 1 Motor
- 2 Flange
- 3 Coupling
- 4 Linear module

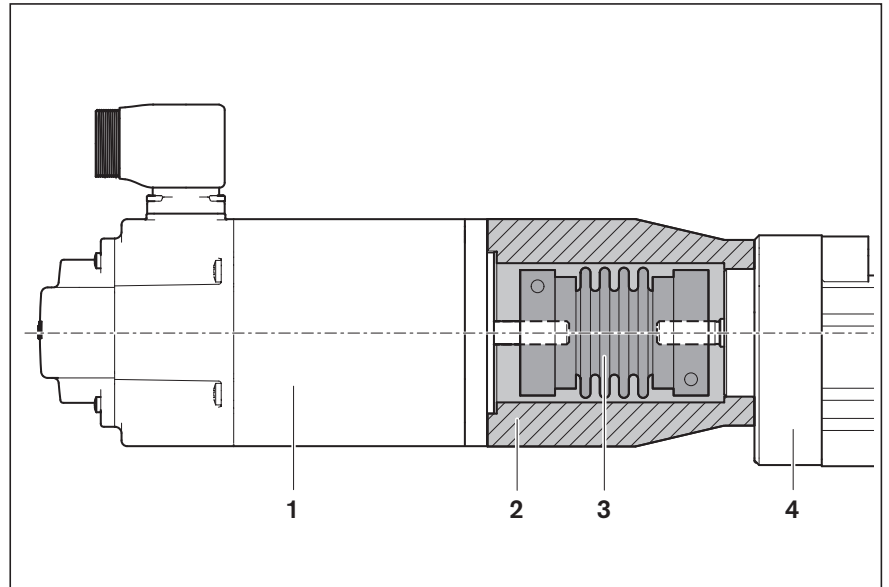

Structure of the belt side drive

All linear modules with a ball screw drive allow for the attachment of the motor via a belt side drive.

This makes the overall length shorter than in case of motor attachment with flange and coupling.

The space-saving, closed pulley housing provides protection for the belt and acts as a motor bracket. In addition, various gear ratios are available.

The belt side drive can be mounted in four different directions:

- 1 Pulley housing made of anodized aluminum frame
- 2 Partially with support bearing for BASA screw journal
- 3 Linear module
- 4 Drive via toothed belt with gear ratio:
 $i = 1; i = 1.5; i = 2$
- 5 Servo motor
- 6 Belt pulley
- 7 Cover
- 8 Belt pulleys attached using tensioning units
- 9 Cover plate

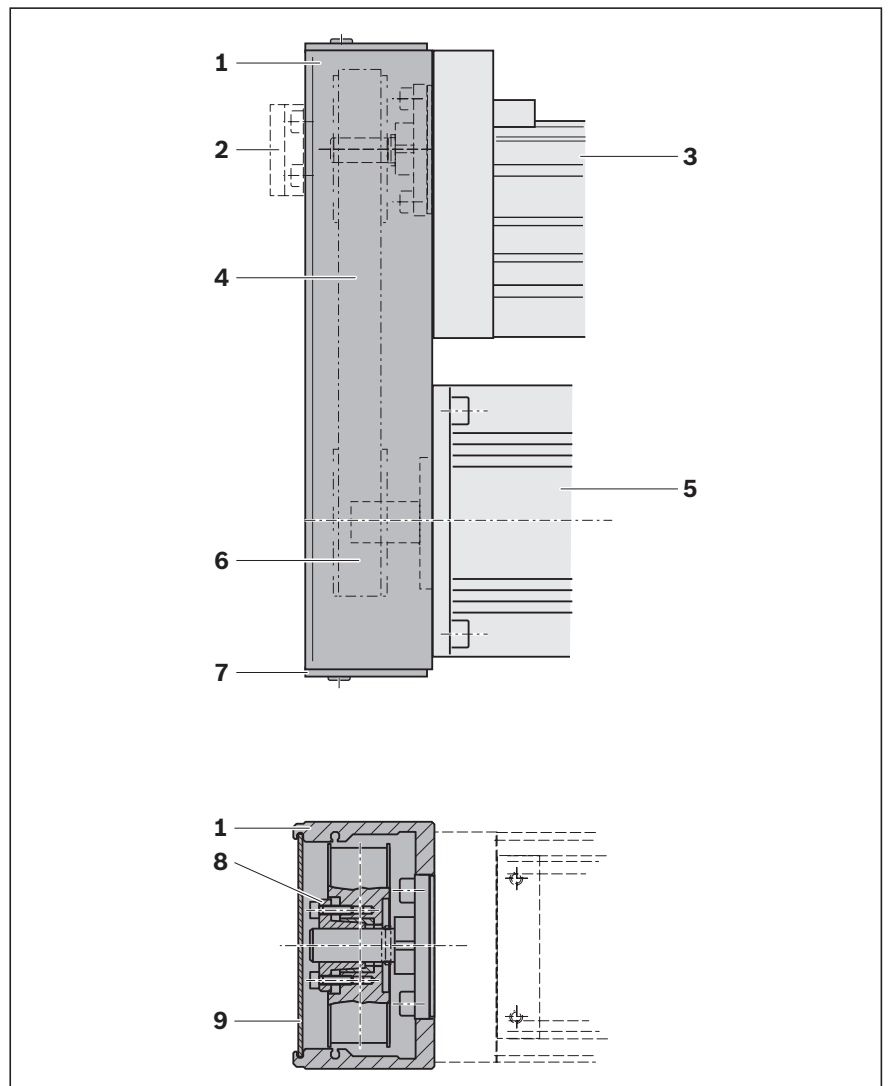

Linear modules MKK

Technical data

General technical data

Observe the chapter "Project planning/calculation"!

MKK	Number of carriages	Carriage		BASA d ₀ x P		Dynamic characteristic values					Maximum permissible loads			
		L _{ca} (mm)	L _w ¹⁾ (mm)	d ₀ (mm)	P (mm)	Load capacities		C _{rib} (N)	Load moments		Moments			
						C _{gw} (N)	C _{bs} (N)			M _t (Nm)	M _L ²⁾ (Nm)	M _{x max} (Nm)	M _{y max} ³⁾ (Nm)	M _{z max} ³⁾ (Nm)
-040-NN-3	1	135	-	12	2	3,750	2,420	4,000	22.3	105	11	53	53	
					5		4,100							
					10		2,700							
-065-NN-3	1	190	-	16	5	16,020	13,320	13,400	154	533	76	262	213	
					10		10,350							
					16		10,080							
	2	2 x 190	variable min = 210 max = 750		5	26,020	13,320		251	13 x L _w	152	7.9 x L _w	7.9 x L _w	
					10		10,350							
					16		10,080							
-080-NN-3	1	260	-	20	5	38,015	15,480	16,900	487	1,843	240	908	908	
					10		15,210							
					20		14,400							
					40		12,600							
	1 (with IMS)	360	-		-	5	61,775		15,480	792	30.9 x L _w	480	18.7 x L _w	18.7 x L _w
						10			15,210					
						20			14,400					
						40			12,600					
	2	260	variable min = 320 max = 960		-	5	75,475		23,310	1,082	37.7 x L _w	656	22.9 x L _w	22.9 x L _w
						10			34,200					
						20			21,240					
						32			21,060					
-110-NN-3	1	305	-	32	5	46,460	23,310	26,000	666	2,235	328	1,100	1,100	
					10		34,200							
					20		21,240							
					32		21,060							
	1 (with IMS)	430	-		-	5	75,475		23,310	1,082	37.7 x L _w	656	22.9 x L _w	22.9 x L _w
						10			34,200					
						20			21,240					
						32			21,060					
	2	305	variable min = 375 max = 1095		-	5	75,475		23,310	1,082	37.7 x L _w	656	22.9 x L _w	22.9 x L _w
						10			34,200					
						20			21,240					
						32			21,060					

¹⁾ Variable center-to-center distance defined by customer-built attachment.

Centerline-to-centerline distance freely selectable between minimum and maximum distance in millimeters steps.

²⁾ Determine the dynamic longitudinal load moment M_L with variable carriage centerline-to-centerline distance according to the selected centerline-to-centerline distance.

³⁾ Determine the maximum permissible longitudinal moments M_{y max} and M_{z max} at variable carriage centerline-to-centerline distance according to the selected centerline-to-centerline distance.

⁴⁾ Minimum required travel range to ensure a reliable lubrication distribution.

For operating conditions, see chapter "Additional information."

If values are not met, please contact Bosch Rexroth.

⁵⁾ Additional length L_{ad} for version with screw support (SPU) 1 pair

⁶⁾ Additional length L_{ad} for version with screw support (SPU) 2 pair

⁷⁾ Maximum permissible length L_{max} for version with screw support (SPU)

⁸⁾ Maximum permissible length L_{max} with material pairing "ALCR"

Length calculation ➡ Chapter "Project planning/calculation"

Short product names ➡ Chapter "Abbreviations"

Size -140 and -165 ➡ next page

	Forces			Additional length L_{ad} (mm)	Min. travel range $s_{min}^{4)}$ (mm)	Max. length L_{max} (mm)	Application point of the effective force z_1 (mm)	Moved mass of system m_{ca} (kg)	Constant mass calculation		Planar moment of inertia	
	$F_{y \max}$ (N)	$F_{z1 \max}$ (N)	$F_{z2 \max}$ (N)						$k_g \text{ fix}$ (kg)	$k_g \text{ var}$ (kg/mm)	I_y (cm ⁴)	I_z (cm ⁴)
	1,875	1,875	1,875	25	50	1,000	42	0.39	0.26	0.0028	11.74	11.72
	6,600	7,890	7,890	34	60	2,500	67	1.57	1.00	0.0075	79.40	90.70
	15,775	15,775	15,775					1.75				
								1.82				
								2.97				
								3.15				
				3.22								
	18,100	18,100	18,100	109	60	2,500 3,400 ⁷⁾	74	2.91	2.00	0.0117	182.00	213.00
	18,100	18,100	8,440	122 ⁵⁾								
				2.86								
				3.14								
				3.20								
	37,740	37,740	37,740	168 ⁶⁾	3.31							
				3.26								
				3.54								
				3.60								
				5.61								
	22,880	22,880	22,880	119	60	4,000 5,400 ⁷⁾ 3,950 ⁸⁾	94	4.75	3.20	0.021	510.00	678.00
				22,880				22,880				
	5.01											
	5.06											
	5.37											
	45,760	45,760	45,760	178 ⁶⁾	6.25							
				6.51								
				6.56								
				6.87								
				9.15								
								9.41				
								9.46				
								9.77				

Linear modules MKK

Technical data

General technical data

Observe the chapter "Project planning/calculation"!

MKK	Number of carriages	Carriage		BASA d ₀ x P		Dynamic characteristic values					Maximum permissible loads			
		L _{ca} (mm)	L _w ¹⁾ (mm)	d ₀ (mm)	P (mm)	Load capacities		Moments			Moments			
						C _{gw} (N)	C _{bs} (N)	C _{fb} (N)	M _t (Nm)	M _L ²⁾ (Nm)	M _{x max} (Nm)	M _{y max} ³⁾ (Nm)	M _{z max} ³⁾ (Nm)	
-140-NN-3	1	370	-	40	5	59,295	54,000	54,000	1,020	3,190	260	1,088	1,572	
					10									
					20									
					40									
	5													
	10													
	20													
	40													
	1 (with IMS)	500	-	5	96,325	31,410	54,000	29,000	1,663	48.2 x L _w	520	20.2 x L _w	20.2 x L _w	
				10										
				20										
				40										
2	370	variable min = 450 max = 1350	5	84,100	31,410	54,000	29,000	1,803	11,980	340	1,286	2,538		
			10											
			20											
			40											
-165-NN-2	1	400	-	without	without	without	without	without	without	without	without	without	without	
				40	5	84,100	31,410	54,000	29,000	1,803	5,130	340	1,286	2,538
					10									
					20									
					40									

¹⁾ Variable center-to-center distance defined by customer-built attachment.

Centerline-to-centerline distance freely selectable between minimum and maximum distance in millimeters steps.

²⁾ Determine the dynamic longitudinal load moment M_L with variable carriage centerline-to-centerline distance according to the selected centerline-to-centerline distance.

³⁾ Determine the maximum permissible longitudinal moments M_{y max} and M_{z max} at variable carriage centerline-to-centerline distance according to the selected centerline-to-centerline distance.

⁴⁾ Minimum required travel range to ensure a reliable lubrication distribution.

For operating conditions, see chapter "Additional information."

If values are not met, please contact Bosch Rexroth.

⁵⁾ Additional length L_{ad} for version with screw support (SPU) 1 pair

⁶⁾ Additional length L_{ad} for version with screw support (SPU) 2 pair

⁷⁾ Maximum permissible length L_{max} for version with screw support (SPU)

⁸⁾ Maximum permissible length L_{max} with material pairing "ALCR"

Length calculation ➡ Chapter "Project planning/calculation"

Short product names ➡ Chapter "Abbreviations"

Forces			Additional length L_{ad} (mm)	Min. travel range $s_{min}^{4)}$ (mm)	Max. length L_{max} (mm)	Application point of the effective force z_1 (mm)	Moved mass of system m_{ca} (kg)	Constant mass calculation		Planar moment of inertia	
$F_{y\ max}$ (N)	$F_{z1\ max}$ (N)	$F_{z2\ max}$ (N)						$k_{g\ fix}$ (kg)	$k_{g\ var}$ (kg/mm)	I_y (cm ⁴)	I_z (cm ⁴)
28,800	28,800	20,200	120 184 ⁵⁾ 228 ⁶⁾	80	4,000 5,400 ⁷⁾ 3,950 ⁸⁾	124	10.53	6.30	0.0342	1,500	1,875
							10.80				
							10.57				
							10.65				
							13.03				
							13.30				
							13.07				
							13.15				
							19.33				
							19.60				
19.37											
19.45											
58,400	58,400	40,400					16.50	7.80	0.045	2,479	3,504
							17.30				
							17.60				
							17.60				
							18.40				
41,400	41,400	21,000	50	80	12,000	123	16.50	7.80	0.045	2,479	3,504
					17.30						
					17.60						
					17.60						
					18.40						

Linear modules MKK

Technical data

Drive data

Observe the chapter "Project planning/calculation"!

MKK	BASA		Constant mass moment of inertia			Friction torque ¹⁾	Max. acceleration	Max. drive torque M_p (Nm)	Max. travel speed v_{max} (m/s)
	$d_0 \times P$ (mm)	Number of carriages	$k_{J \text{ fix}}$ (kgmm ²)	$k_{J \text{ var}}$ (kgmm)	$k_{J \text{ m}}$ (mm ²)				
-040-NN-3	12 x 2	1	1.274	0.013	0.101	0.09	48.4	See graphs	See graphs
	12 x 5	1	1.468	0.011	0.633	0.10	50.0		
	12 x 10	1	2.201	0.011	2.533	0.11	50.0		
-065-NN-3	16 x 5	1	4.315	0.031	0.633	0.40	50.0		
		2	5.202						
	16 x 10	1	7.754	0.031	2.533	0.40			
		2	11.300						
	16 x 16	1	15.112	0.034	6.480	0.40			
		2	24.191						
-080-NN-3	20 x 5	1	11.226	0.084	0.633	0.40	39.8		
		2	12.936						
		1 (with IMS)	11.479						
	20 x 10	1	16.628	0.084	2.533	0.50	50.0		
		2	23.467						
		1 (with IMS)	17.651						
	20 x 20	1	41.223	0.081	10.140	0.50	50.0		
		2	68.580						
		1 (with IMS)	45.276						
	20 x 40	1	139.057	0.086	40.530	0.70	50.0		
		2	248.480						
		1 (with IMS)	155.268						
-110-NN-3	32 x 5	1	49.600	0.605	0.633	1.10	17.9		
		2	52.386						
		1 (with IMS)	50.550						
	32 x 10	1	59.037	0.640	2.533	1.10	30.7		
		2	70.183						
		1 (with IMS)	62.837						
	32 x 20	1	97.623	0.639	10.140	1.00	50.0		
		2	142.204						
		1 (with IMS)	112.821						
	32 x 32	1	185.796	0.617	25.940	1.00	50.0		
		2	299.925						
		1 (with IMS)	224.703						
-140-NN-3	40 x 5	1	246.800	1.564	0.633	2.10	12.2		
		2	252.200						
		1 (with IMS)	248.400						
	40 x 10	1	263.300	1.355	2.533	2.50	16.8		
		2	284.900						
		1 (with IMS)	269.600						
	40 x 20	1	342.900	1.352	10.140	2.20	33.8		
		2	429.100						
		1 (with IMS)	368.300						
	40 x 40	1	667.300	1.342	40.530	2.30	50.0		
		2	1 012.000						
		1 (with IMS)	768.700						
-165-NN-2	40 x 5	1	217.000	1.564	0.633	2.00	12.2		
	40 x 10	1	248.000	1.355	2.533	2.40	16.8		
	40 x 20	1	381.000	1.352	10.140	2.20	33.0		
	40 x 40	1	947.000	1.342	40.530	2.60	50.0		

¹⁾ at 200 rpm

Values also valid for the carriage version with variable centerline-to-centerline distance

Drive data for motor attachment with belt side drive

MKK	Motor	BASA $d_0 \times P$ (mm)	Length up to L ¹⁾ (mm)	Permissible torque		Reduced mass moment of inertia		Friction torque M_{Rsd} (Nm)	Mass		Belt type	
				$M_{sd}^{2)}$ (Nm)	$M_{sd}^{2)}$ (Nm)	J_{sd} (10 ⁻⁶ kg/m ²)	J_{sd} (10 ⁻⁶ kg/m ²)		m_{sd} (kg)	m_{sd} (kg)	B_t	B_t
				$i = 1^{3)}$	$i = 1.5^{3)}$	$i = 1^{3)}$	$i = 1.5^{3)}$		$i = 1^{3)}$	$i = 1.5^{3)}$	$i = 1^{3)}$	$i = 1.5^{3)}$
-040-NN-3	MSM019B	12 x 2	1,000	0.79	0.53	10.7	4.1	0.10	0.28	0.26	6 AT3	6 AT3
		12 x 5		1.31	0.87							
		12 x 10		1.31	0.87							
	MS2N03-B MSM031B	12 x 5		0.79	0.53	34.8	13.0	0.15	0.63	0.60	10 AT3	10 AT3
		12 x 5		2.49	1.66							
		12 x 10		2.70	1.80							
-065-NN-3	MSM041B MS2N04	16 x 5	1,100	4.31	2.87	234.4	83.6	0.40	1.45	1.32	16 AT5	16 AT5
		16 x 10	1300	5.85	3.90							
		16 x 16	1,550	6.42	4.28							
-080-NN-3	MSM041B MS2N04	20 x 5	1,600	5.90	3.90	250.0	85.0	0.40	1.24	1.27	16 AT5	16 AT5
		20 x 10	2,000	7.60	5.00							
		20 x 20	2,500	8.30	5.50							
		20 x 40	2,500	8.50	5.70							
				$i = 1$	$i = 1.5$							
-080-NN-3	MS2N05	20 x 5	1,600	5.90	2.95	1,420.0	230.00	0.45	3.20	2.90	25 AT5	25 AT5
		20 x 10	2,000	7.70	3.85							
		20 x 20	2,500	8.50	4.25							
		20 x 40	2,500	8.70	4.35							
				$i = 1$	$i = 2$							
-110-NN-3	MS2N06	32 x 5	2,500	20.60	10.30	1,400.0	260.0	0.50	3.20	2.90	25 AT5	32 AT5
		32 x 10	3,200	22.80	14.60							
		32 x 20	4,300	22.80	14.60							
		32 x 32	5,400	22.80	14.60							
-140-NN-3	MS2N07	40 x 5	2,500	27.70	13.85	7,780.0	1,260.0	0.60	8.60	7.50	50 AT10	50 AT10
		40 x 10	1,800	72.00	36.00							
		40 x 20	2,200	96.30	48.15							
		40 x 40	3,000	108.90	54.45							
-165-NN-2	MS2N07	40 x 5	2,800	26.00	13.00	7,780.0	1,260.0	0.60	8.40	7.20	50 AT10	50 AT10
		40 x 10	2,400	52.00	26.00							
		40 x 20	2,400	99.30	49.60							
		40 x 40	3,300	99.30	49.60							

1) For greater lengths, the permissible drive torque is determined from the length-variable value M_p of the linear motion system in accordance with the diagram ! See chapter "Calculation principles"

2) Values for M_{sd} do not factor in motor torque.

3) With support bearing

Drive data for motor attachment with flange and coupling

MKK	Motor	Coupling	M_{cN} (Nm)	J_c (10 ⁻⁶ kg/m ²)	m_c (kg)	Flange and coupling
						m_{fc} (kg)
-040-NN-3	MS2N03-B		3.7	7.0	0.075	0.26
	MSM019B		1.9	2.1	0.039	0.13
	MSM031B		3.7	7.0	0.075	0.29
-065-NN-3	MS2N04		19.0	57.0	0.260	0.75
	MSM041B		9.0	61.0	0.260	0.85
-080-NN-3	MS2N04		19.0	57.0	0.260	1.00
	MS2N05		50.0	210.0	0.700	1.90
	MSM041B		14.5	63.0	0.260	0.90
-110-NN-3	MS2N06		50.0	210.0	0.700	1.80
-140-NN-3	MS2N07		115.0	390.0	0.900	2.80
-165-NN-2	MS2N07		115.0	390.0	0.900	2.80

Linear modules MKK

Technical data

Permissible drive torque M_p

The values for M_p apply under the following conditions:

- Screw journal without keyway
- No radial loads on screw journal

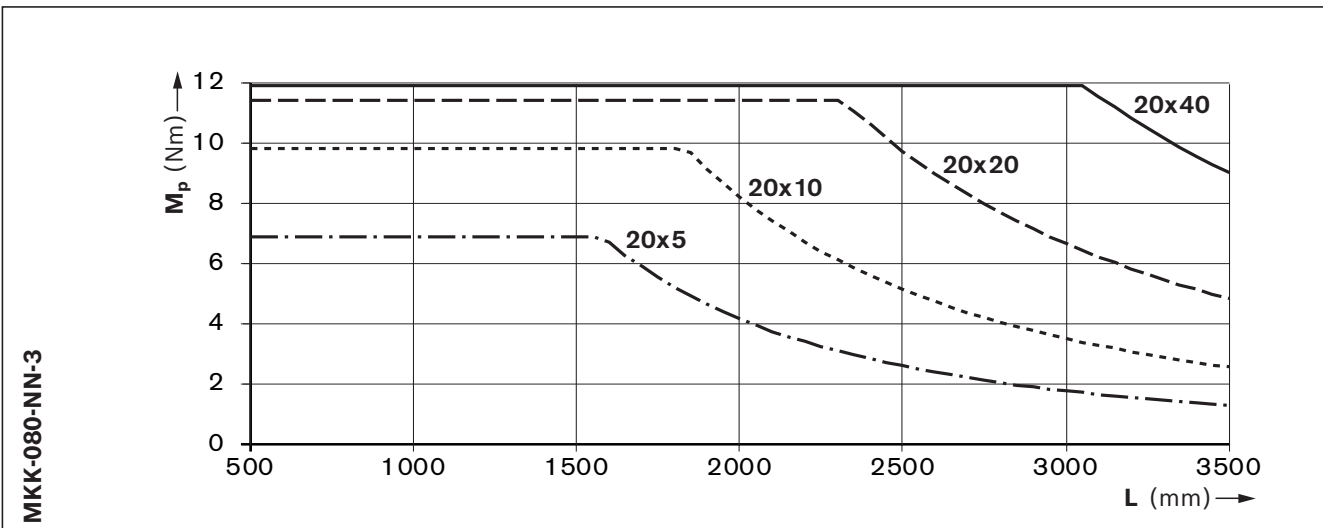
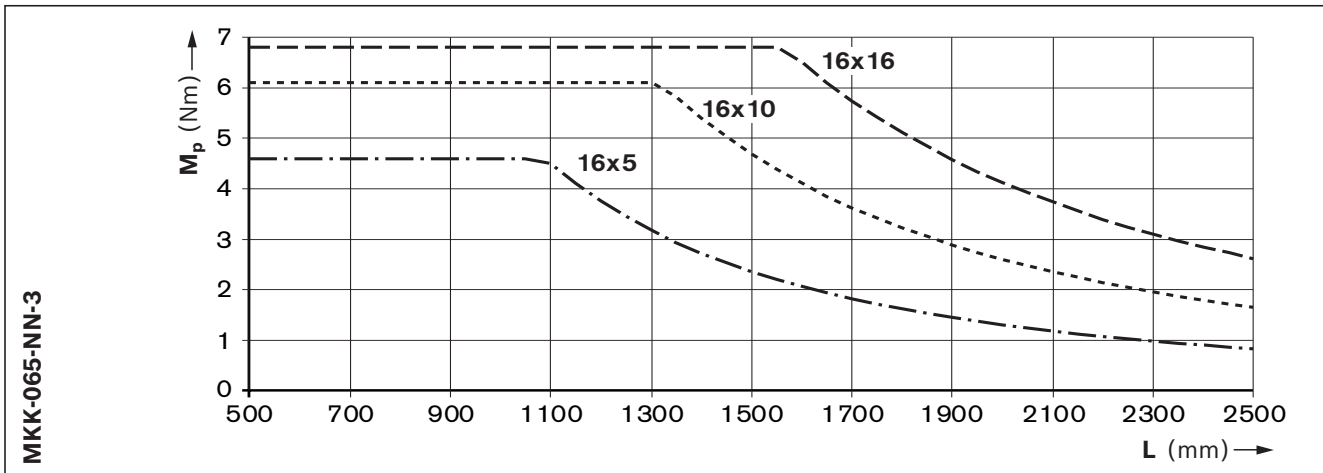
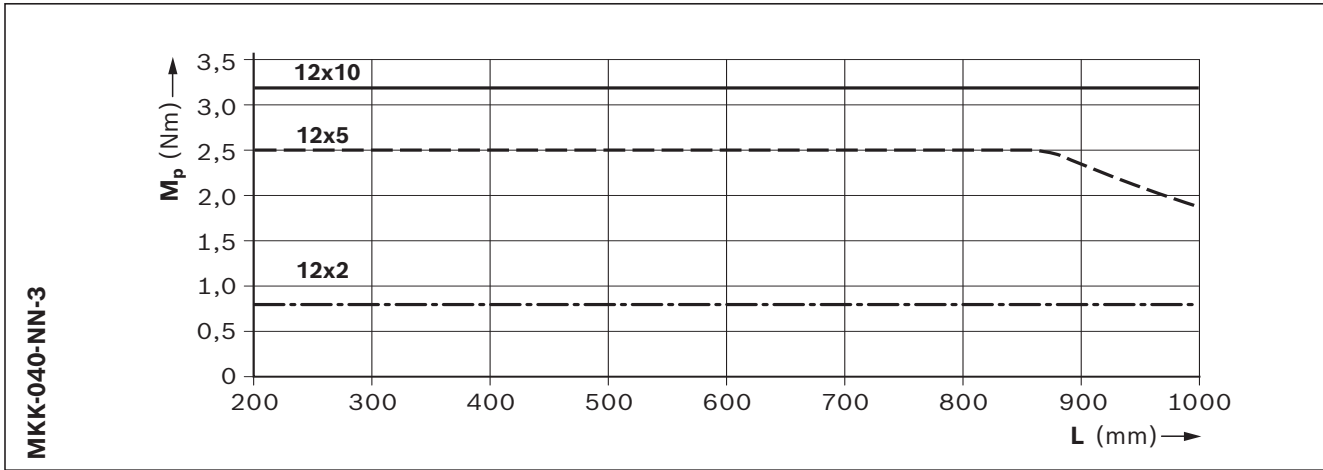

⚠ Screw journal with keyway

For reasons of stress concentration and a reduction of the effective diameter, observe the maximum value $M_p = 48 \text{ Nm}$ for drive torque! (applicable to ball screw drive 32x20 and 32x32)

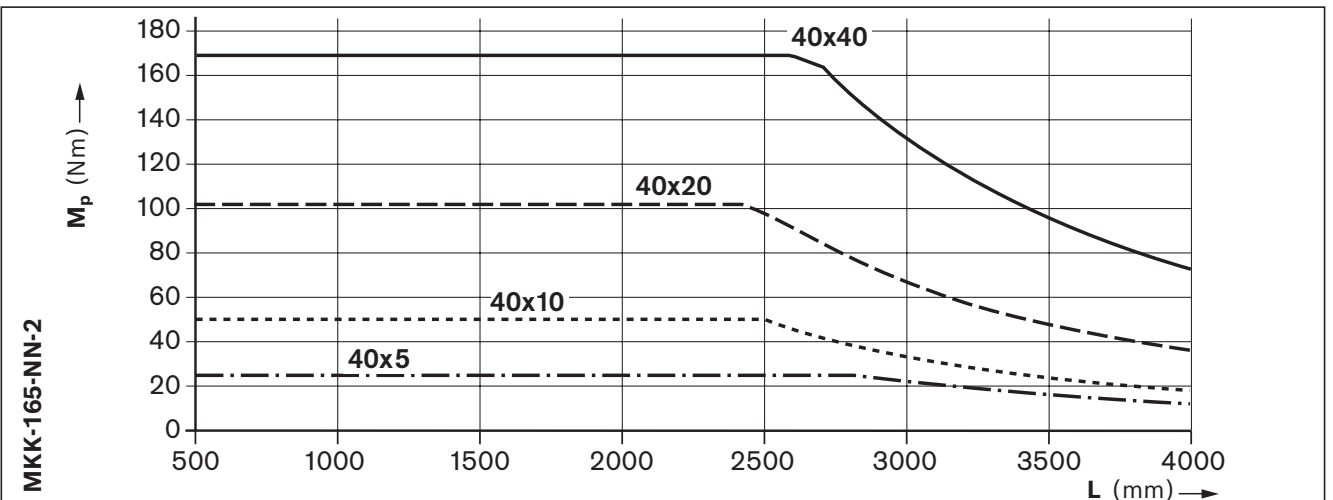
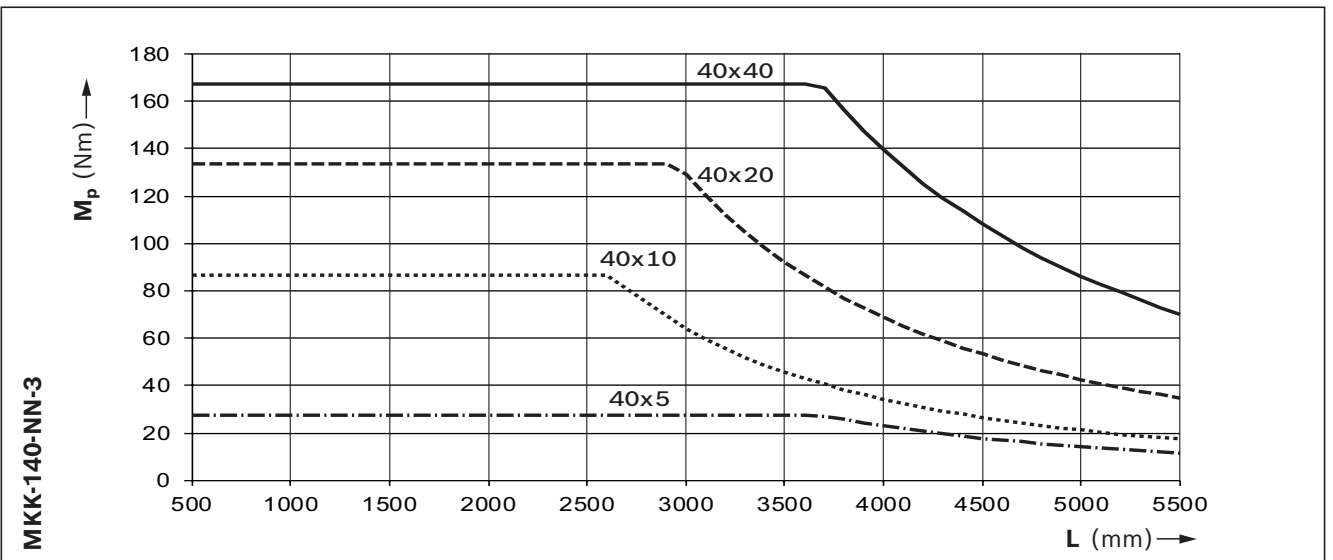
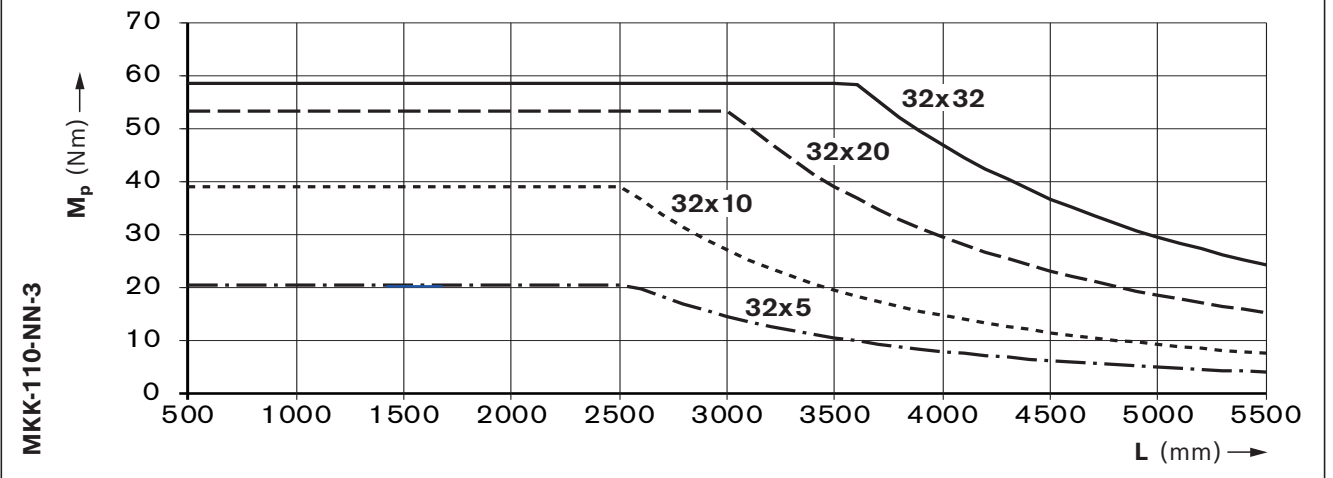

Linear modules MKK

Technical data

Permissible speed v_{max}

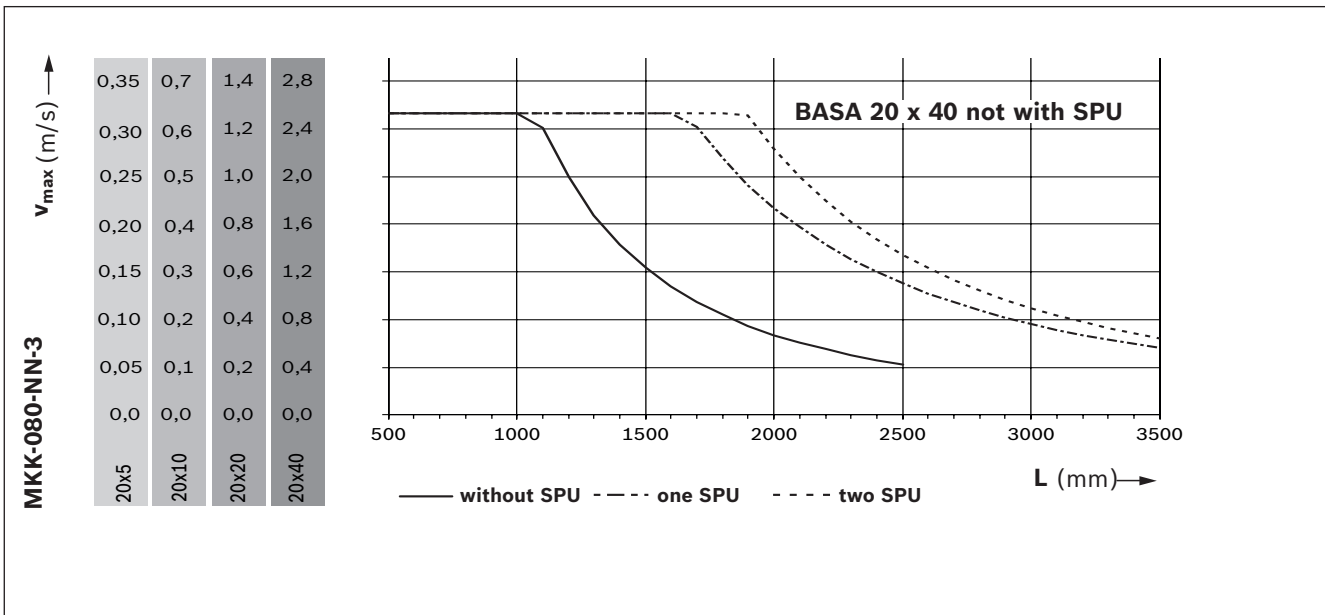
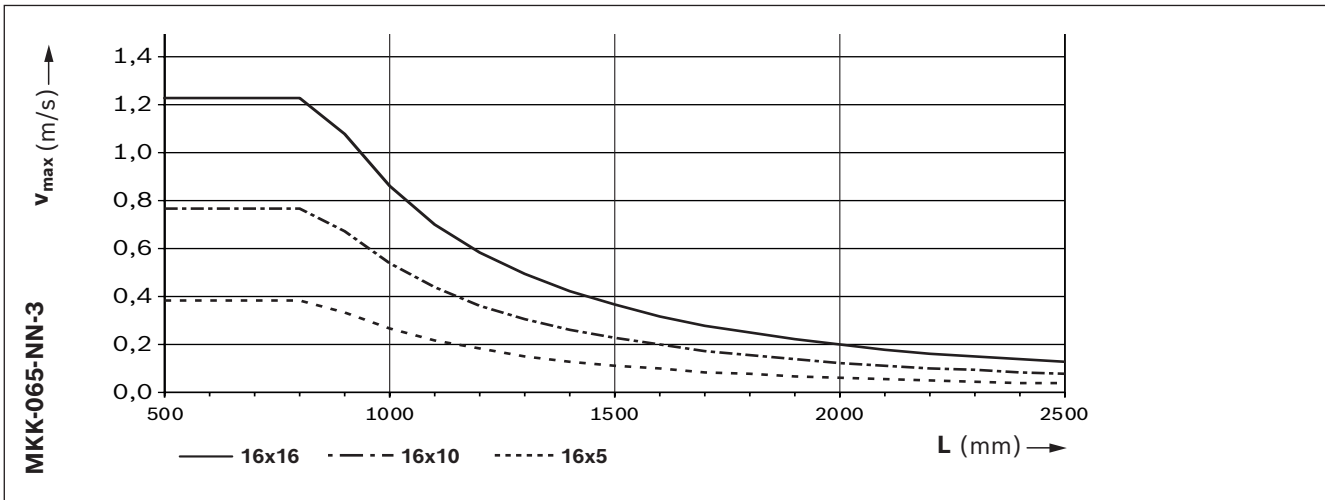
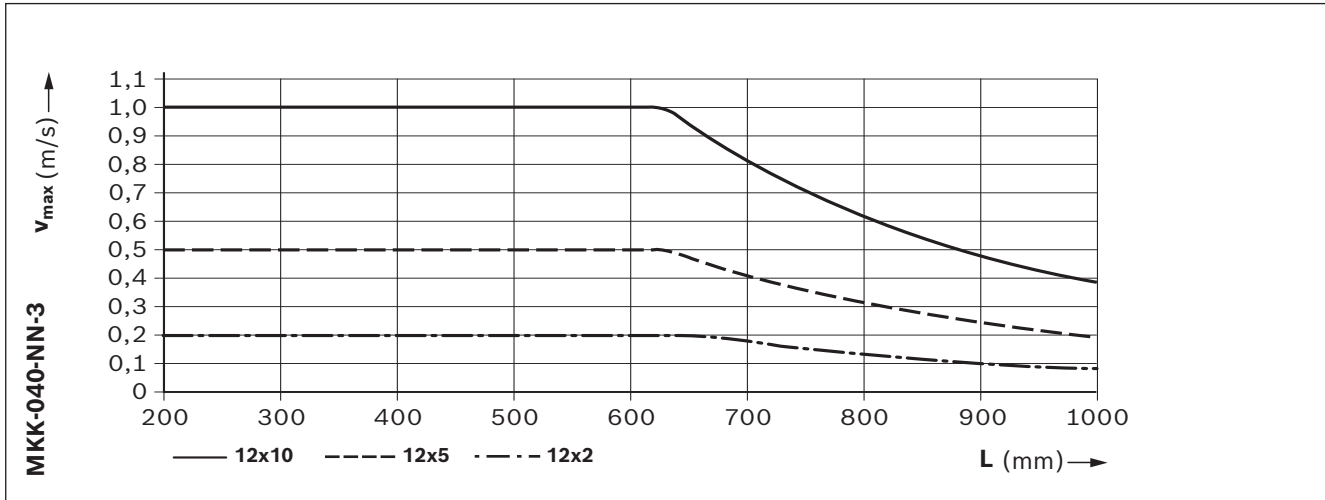

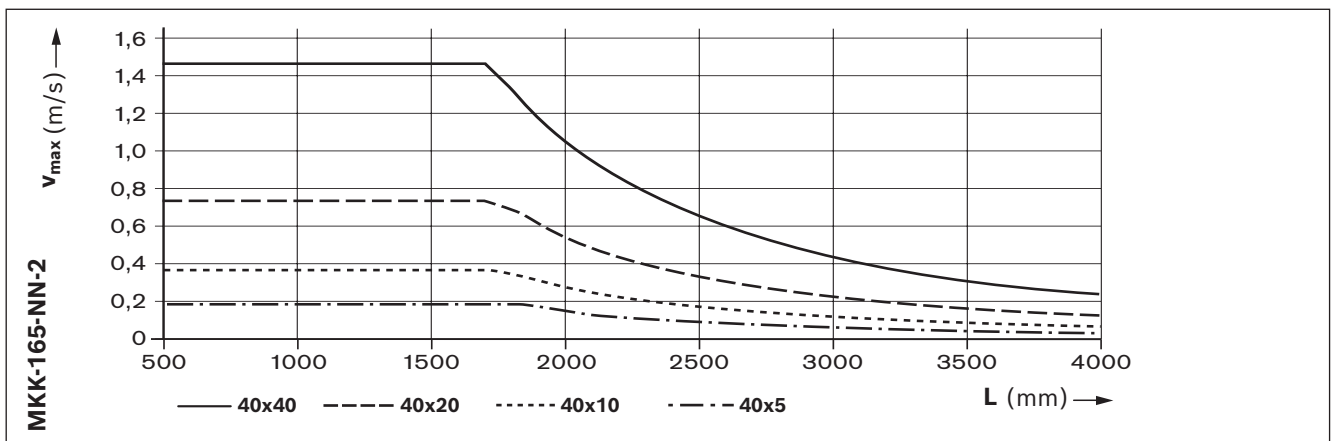
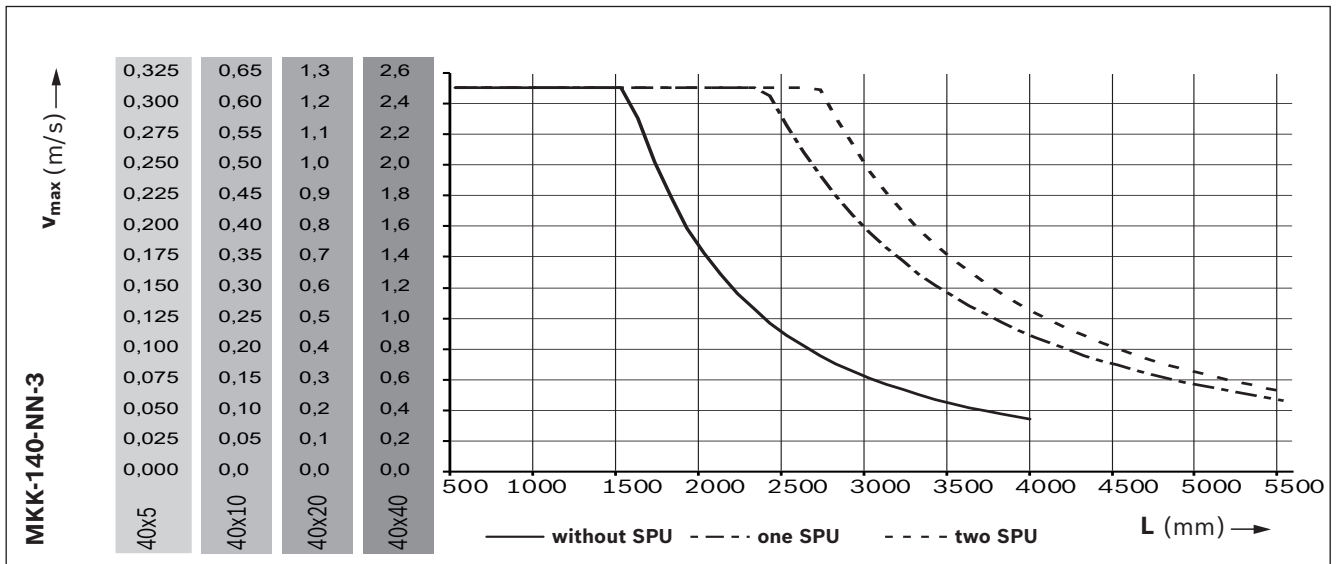
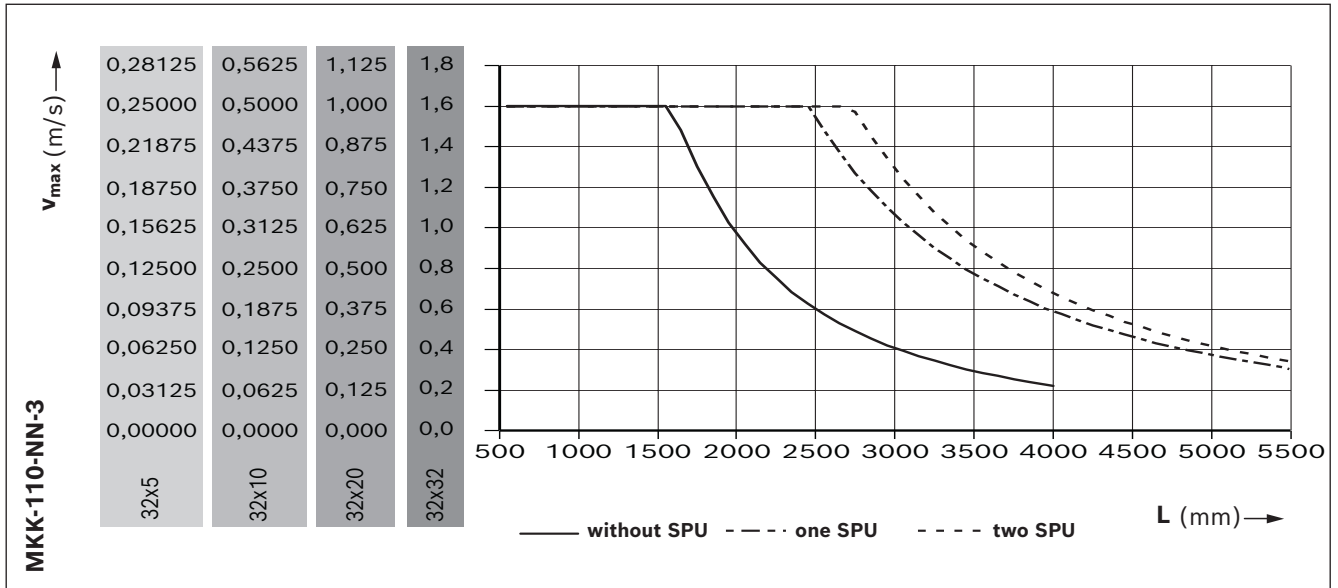

Linear modules MKK

Technical data

Deflection f

Observe the "General technical instructions" chapter

Example: The graphs apply under the following conditions:
 - both ends firmly fixed (200 to 250 mm per side)
 - 6 to 8 screws per side fixed mounting base
 - Note L_{max} ; see general technical data

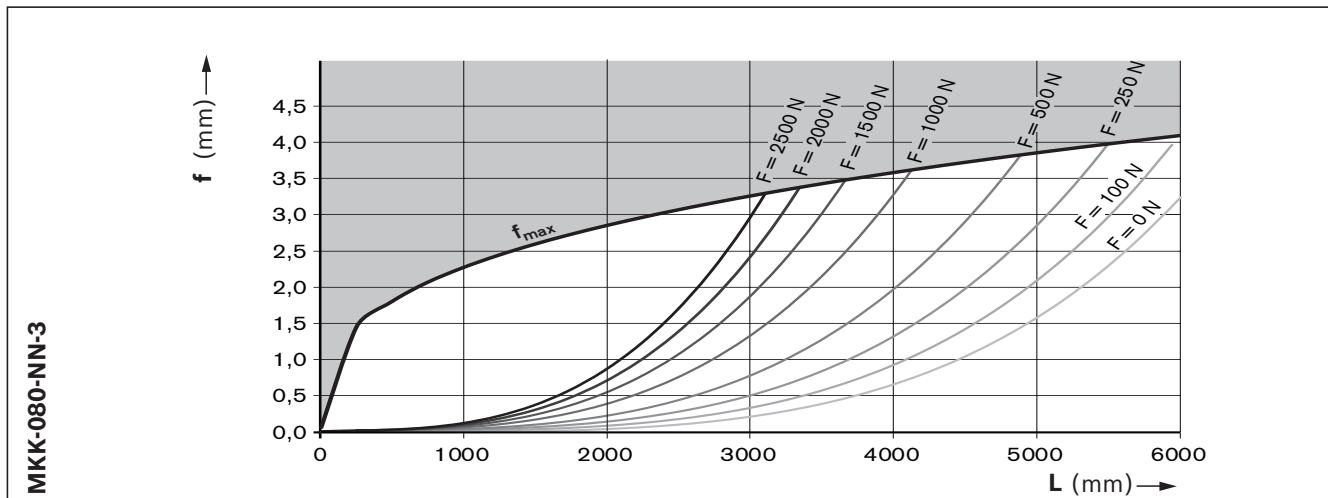
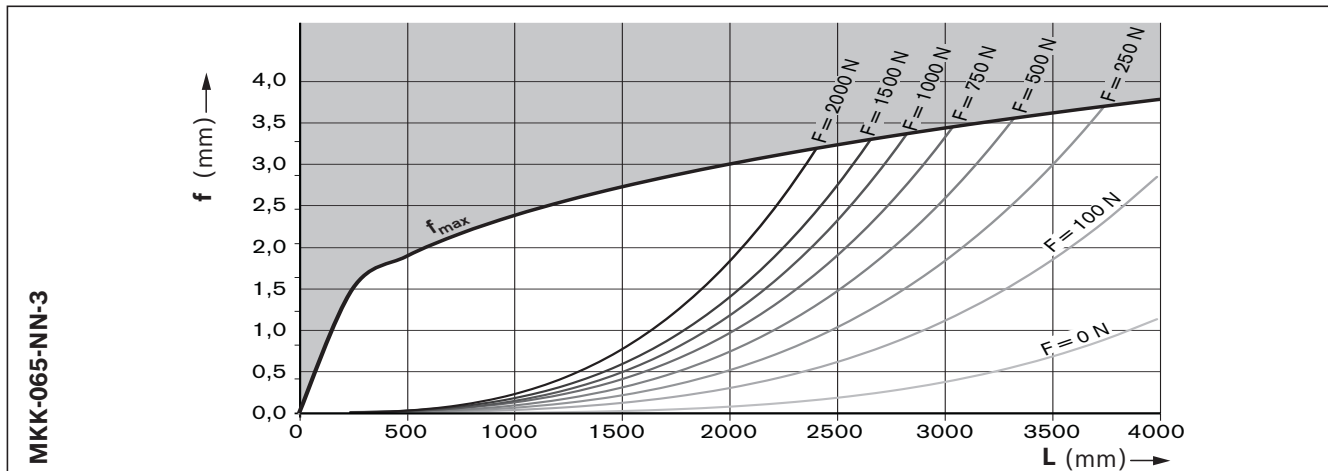
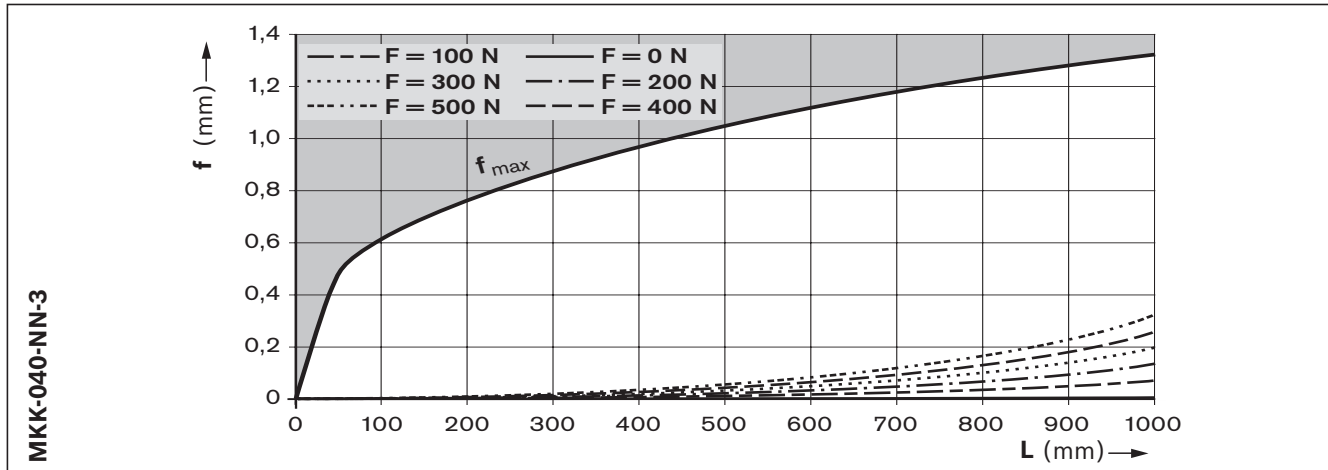

Linear module MKK-080: $L = 3000$ mm, $F = 1500$ N
 From chart MKK-080: $f = 1.8$ mm $f_{max} = 3.5$ mm
 The deflection f lies well below the maximum permissible deflection f_{max} , so no additional supports are required.

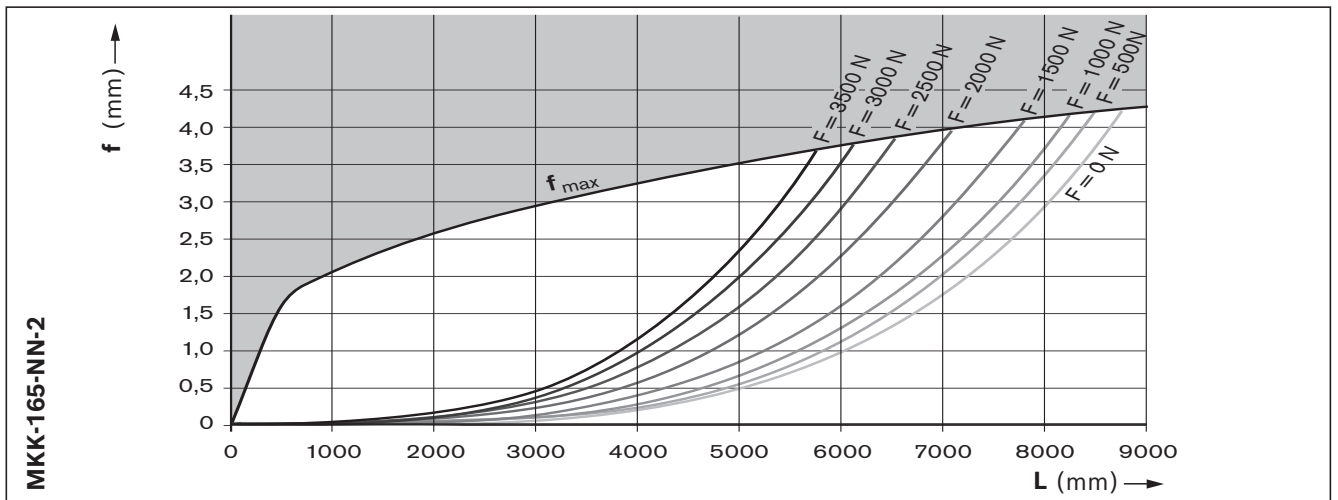
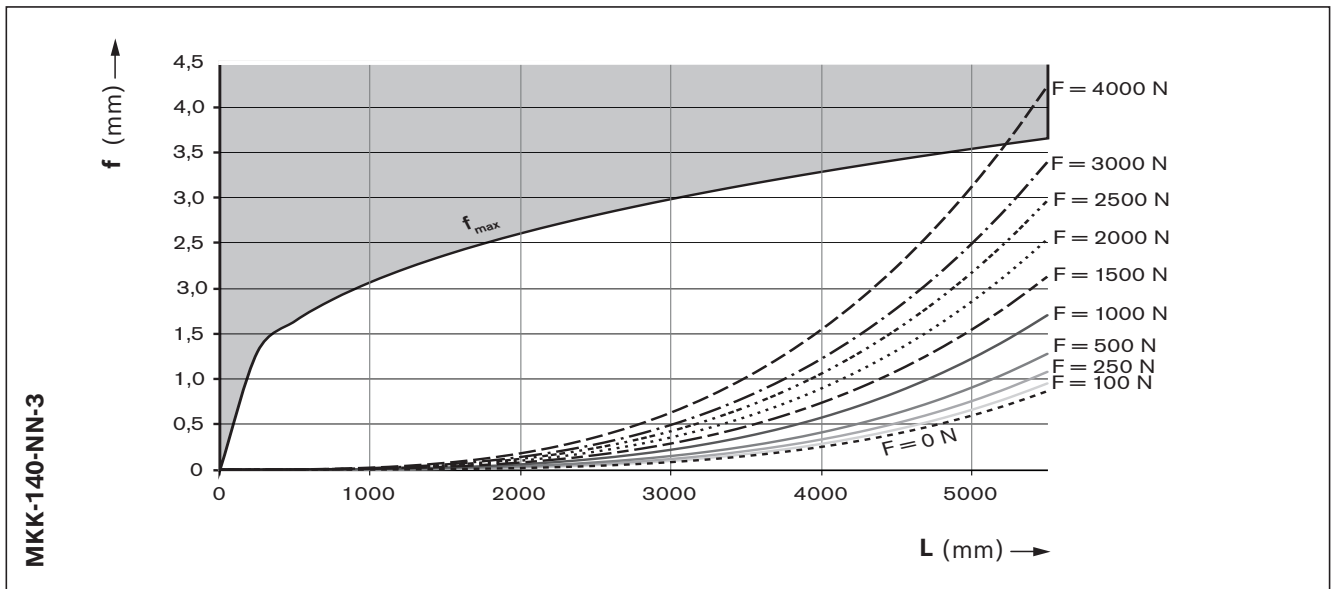
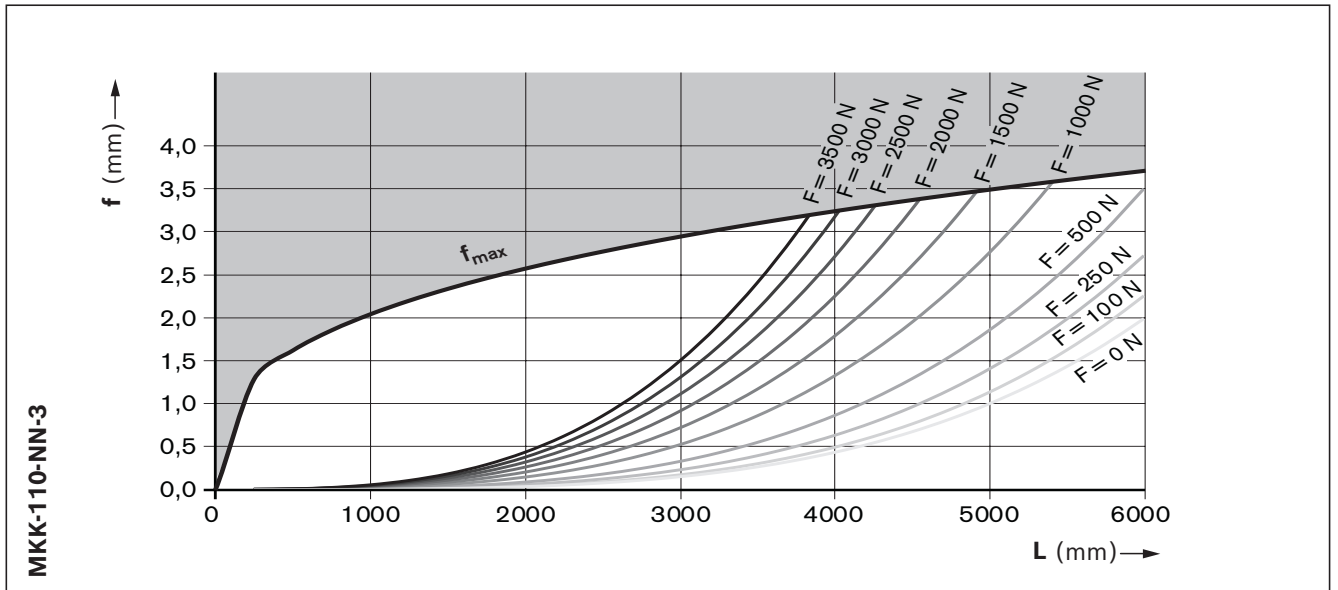

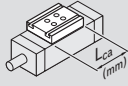

MKK-040-NN-3

Configuration and ordering

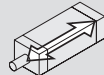
$s_{max.}^1)$ (mm)	Material pairing ²⁾	Lubrication ³⁾	Carriage (TT) 		Guideway ⁴⁾ 	Drive 	
			Thread (T) $L_{ca} = 135 \text{ mm}$	Number TT	Frame with or without centering holes	BASA	Tolerance grade
$s_{max} =$	ALST (Aluminum/steel)	LSS	T	1	001 without	12x2	T5
		LCF				12x5	T7
		LCO			004 with	12x2	T5
		LPG				12x5	T7
	ALCR (Aluminum/hard chrome plated steel)	LSS	T	1	001 without	12x5	T7
		LCF					
		LCO			004 with	12x10	
		LPG					

1) Travel range s_{max} depends on length L and option selection Length calculation \Rightarrow Chapter "Project planning/calculation"

2) Material pairing \Rightarrow Chapter "Product description MKK-xxx-NN-3."

3) Lubrication \Rightarrow see chapter "Additional information".

4) Centering holes for simple combination with other linear motion systems and connection elements (see dimension drawings).

Option 004: with centering holes and long hole in the base area of the frame from travel range $s_{min} \geq 140 \text{ mm}$.

5) Attachment kit also available without motor.

Mounting kits according to customer specification \Rightarrow Chapter "Motor attachment kits according to customer specification".

6) Further switch mounting options \Rightarrow Chapter "Switching system."

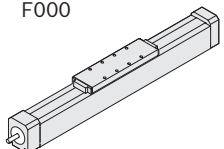
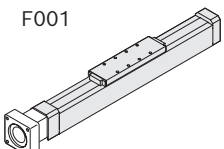
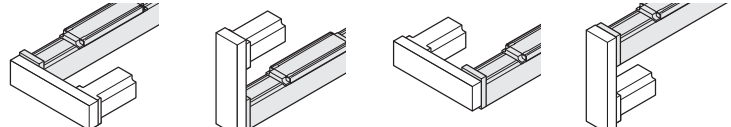
Version	Attachment interface ⁵⁾		Motor					Cover		Sensor system ⁶⁾	Automation package	Documentation						
	Gear ratio	Mechanical interface	Motor code	1 cable	2 cables	with	without	Motor connector position	Cover	Side sealing	Quantity: 1-6	Controller	Cables	Software				
F000																		
																		
F000 (without flange)	-	-	-	-	-	-	-	-	0	0	000	Chapter "Automation package"			001 standard; 002 friction torque 003 lead deviation; 005 positioning accuracy			
F001																		
																		
F001 (with flange)	i = 1	MS2N03-B MSM019B MSM031B	MS2N03-B0BYN MSM019B-0300 MSM031B-0300	1 - -	- 2 2	Y	N	000 090 180 270	0	0	000							
S000 S090 S180 S270																		
																		
S000 S090 S180 S270 (with belt side drive)	i = 1	MS2N03-B MSM019B MSM031B	MS2N03-B0BYN MSM019B-0300 MSM031B-0300	1 - -	- 2 2	Y	N	000 090 180 270	2	0	000							
	i = 1.5	MS2N03-B MSM019B MSM031B	MS2N03-B0BYN MSM019B-0300 MSM031B-0300	1 - -	- 2 2	Y	N	180 270			090							

Flange	Motor connector position			
	0 °	90 °	180 °	270 °
F001	000	090 ★	180	270

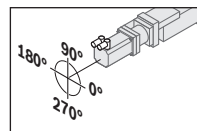

Example:
Flange F001
Motor connector position 90°

Belt side drive	Motor connector position			
	0 °	90 °	180 °	270 °
S000	-	090	180 ★	270
S090	000	090 ★	180	-
S180	000 ★	090	-	270
S270	000	-	180	270 ★

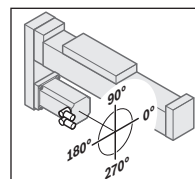



Example:
Timing belt side drive S270
Motor connector position 180°

★ Standard delivery (connector position)

MKK-065-NN-3

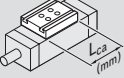
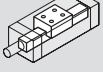
Configuration and ordering

$s_{max.}^1)$ (mm)	Material pairing ²⁾	Lubrication ³⁾ 	Carriage (TT) 		L_w (mm) (2 TT only)	Guideway Frame with or without centering holes 	Drive ⁴⁾ 		
			T-slot (S) Thread (T) $L_{ca} = 190$ mm	Number TT			Keyway	BASA	Tolerance grade
$s_{max} =$	ALST (Aluminum/steel)	LSS	S	2	$L_w =$	001 without	0 without	16x5	T5
			T	1				16x10	
		S	1		16x16		T7		
		T		1	16x5				
	LCF	S	1		-	004 with	1 with	16x10	T7
		T		16x16					
	ALCR (Aluminum/hard chrome plated steel)	LSS	S	1	-	011 without	0 without	16x5	T7
								T	
T			1	-	014 with			16x16	
								16x16	

1) Travel range s_{max} depends on length L and option selection Length calculation ➡ Chapter "Project planning/calculation"

2) Material pairing ➡ Chapter "Product description MKK-xxx-NN-3."

3) Lubrication ➡ see chapter "Additional information".

4) Drive journal with keyway only available with F000 version!

5) Attachment kit also available without motor.

Mounting kits according to customer specification ➡ Chapter "Motor attachment kits according to customer specification".

6) Further switch mounting options ➡ Chapter "Switching system."

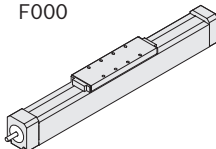
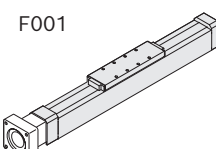
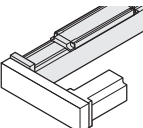
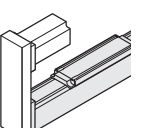
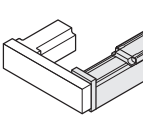
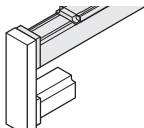
Version	Attachment interface ⁵⁾		Motor						Cover		Sensor system ⁶⁾	Automation package	Documentation			
	Gear ratio	Mechanical interface	Motor code	Con- nection		Holding brake		Motor connector position	Cover	Side sealing	Quantity: 1-6	Controller	Cables	Software		
F000																
																
F000 (without flange)	-	-	-	-	-	-	-	-	0	with- out	0	with- out	000 without switch / 120 sensor, PNP / normally closed (NC) 121 sensor, NPN / normally closed (NC) / 122 sensor, M8x1, PNP / normally open (NO) 123 sensor, M8x1, NPN / normally open (NO)			
F001																
																
F001 (with flange)	i = 1	MS2N04	MS2N04-C0BTN	1	-	Y	N	000	2	with	1	with			Chapter "Automation package"	
		MSM041	MSM041B-0300	-	2	180	270									
   																
S000 S090 S180 S270 (with belt side drive)	i = 1	MS2N04	MS2N04-B0BTN	1	-	Y	N	000	2	with	1	with	001 standard; 002 friction torque 003 lead deviation; 005 positioning accuracy			
		MSM041	MSM041B-0300	-	2			090								
	i = 1.5	MS2N04	MS2N04-B0BTN	1	-			180								
		MSM041	MSM041B-0300	-	2			270								

Flange	Motor connector position			
	0 °	90 °	180 °	270 °
F001	000	090 ★	180	270

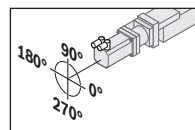

Example:
Flange F001
Motor connector
position 90°

Belt side drive	Motor connector position			
	0 °	90 °	180 °	270 °
S000	-	090	180 ★	270
S090	000	090 ★	180	-
S180	000 ★	090	-	270
S270	000	-	180	270 ★

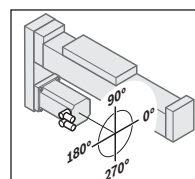

Example:
Timing belt side drive S270
Motor connector
position 180°

★ Standard delivery (connector position)

MKK-080-NN-3

Configuration and ordering

s _{max.} ¹⁾ (mm)	Material pairing ²⁾	Lubri- cation ³⁾	Measuring system IMS- A ⁴⁾	Carriage ⁵⁾⁶⁾ (TT)		L _w (mm)	Guideway	Drive ⁶⁾⁸⁾			SPU ⁹⁾¹⁰⁾															
				T-slot (S) Thread (T) L _{ca} = 260 mm ⁷⁾	Number TT			(2 TT only)	Frame with or without centering holes	Keyway		BASA	Tolerance grade													
s _{max} =	ALST (Aluminum/steel)	LSS	001 (HF)	S	1	-	104 with	0 without	20x5	T5	010 without SPU															
			002 (DQ)	T																						
			000 without	S	2	L _w =	001 without					20x10	T7													
				T																						
		20x20	S	1	-	004 with		20x40	T7																	
			T																							
		LCF	-	S	1		-	004 with	1 with	T7		20x5	20x10	20x20	20x40	001 with SPU (1 pair)										
																	LCO	T								
						LPG													-	S	1	-	011 without	20x5	20x10	20x20
																	ALCR (Aluminum/hard chrome plated steel)	LSS								
LCF	T	014 with	20x5	20x10	20x20	20x40																				

1) Travel range s_{max} depends on length L and option selection Length calculation ➡ Chapter "Project planning/calculation"
 2) Material pairing ➡ Chapter "Product description MKK-xxx-NN-3."
 3) Lubrication ➡ see chapter "Additional information".
 4) No SPU available for version with IMS. IMS measuring system not available with BASA 20x40.
 5) Carriage version "2 TT" optionally available without screw support (SPU).
 6) Thread (T) carriage version not available with BASA 20x40.
 7) Carriage with measuring system, L_{ca} = 360 mm
 8) Drive journal with keyway only available with F000 version!
 9) SPU only possible for carriage version "1 TT!"
 10) No SPU is available for BASA 20x40.
 11) Attachment kit also available without motor.
 Mounting kits according to customer specification ➡ Chapter "Motor attachment kits according to customer specification".
 12) Further switch mounting options ➡ Chapter "Switching system."

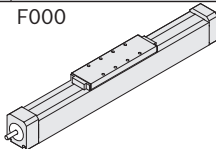
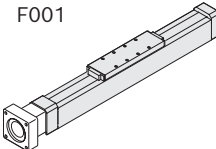
Version	Attachment interface ¹¹⁾		Motor						Cover		Sensor system ¹²⁾	Automation package	Documentation					
	Gear ratio	Mechanical interface	Motor code	Connection		Holding brake		Motor connector position	Cover	Side sealing	Quantity: 1-6	Controller	Cables	Software				
				1 cable	2 cables	with	without											
 F000																		
F000 (without flange)	-	-	-	-	-	-	-	-	0	0	000 without sensor / 120 sensor (PNP NC); 121 sensor (NPN NC) 122 sensor (PNP NO); 123 sensor (NPN NO)	Chapter "Automation package"	001 standard; 002 friction torque 003 lead deviation; 005 positioning accuracy					
 F001																		
F001 (with flange)	i = 1	MS2N04	MS2N04-B0BTN	1	-	Y	N	000	2	with								
			MS2N04-C0BTN	1	-			090										
		MSM041	MSM041B-0300	-	2	180												
			MS2N05	MS2N05-B0BTN	1	-	270											
 S000 S090 S180 S270																		
S000 S090 S180 S270 (with belt side drive)	i = 1	MS2N05	MS2N05-C0BTN	1	-	Y	N	000	1	with								
			MS2N05-D0BRN	1	-			090										
		MS2N04	MS2N04-C0BTN	1	-			180										
			MS2N04-D0BQN	-	2			270										
	i = 1.5	MS2N04	MS2N04-B0BTN	1	-	Y	N	180										
			MS2N04-C0BTN	-	2			270										
		MSM041	MSM041B-0300	-	2			270										
			MS2N05	MS2N05-B0BTN	1			-			270							

Flange	Motor connector position			
	0°	90°	180°	270°
F001	000	090 ★	180	270

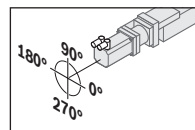

Example:
Flange F001
Motor connector position 90°

Belt side drive	Motor connector position			
	0°	90°	180°	270°
S000	-	090	180 ★	270
S090	000	090 ★	180	-
S180	000 ★	090	-	270
S270	000	-	180	270 ★

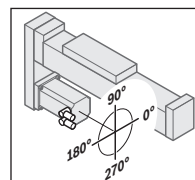

Example:
Timing belt side drive S270
Motor connector position 180°

★ Standard delivery (connector position)

MKK-110-NN-3

Configuration and ordering

$s_{max.}^{1)}$ (mm)	Material pairing ²⁾	Lu- brica- tion ³⁾	Measuring system IMS- A ⁴⁾	Carriage ⁵⁾ (TT)		L_w (mm)	Guideway	Drive ⁷⁾			SPU ⁸⁾
				T-slot (S) Thread (T) $L_{ca} = 305 \text{ mm}^{6)}$	Number TT			Keyway	BASA	Tolerance grade	
$s_{max} =$	ALST (Aluminum/steel)	LSS	001 (HF)	S	1	-	104 with	0 with- out	32x5	T5	010 without SPU
			002 (DQ)	T							
		without	S	2	$L_w =$	001 without	32x10	T7			
			T								
		LCF	S	1	-	004 with	32x20	T7			
			T								
	LCO	-	1	-	004 with	32x10	T7				
	LPG	T									
	ALCR (Aluminum/hard chrome plated steel)	LSS	S	1	-	011 without	0 with- out	32x5	T7	002 with SPU (2 pair)	
		LCF	S								
LCO		-									
LPG		T									

1) Travel range s_{max} depends on length L and option selection Length calculation ➡ Chapter "Project planning/calculation"

2) Material pairing ➡ Chapter "Product description MKK-xxx-NN-3."

3) Lubrication ➡ see chapter "Additional information".

4) No SPU available for version with IMS

5) Carriage version "2 TT" optionally available without screw support (SPU).

6) Carriage with measuring system, $L_{ca} = 430 \text{ mm}$

7) Drive journal with keyway only available with F000 version!

8) SPU only possible for carriage version "1 TT"!

9) Attachment kit also available without motor.

Mounting kits according to customer specification ➡ Chapter "Motor attachment kits according to customer specification".

10) Further switch mounting options ➡ Chapter "Switching system."

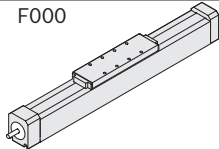
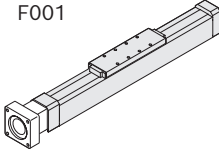
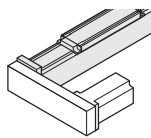
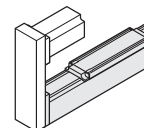
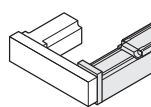
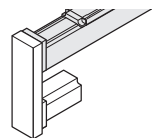
Version	Attachment interface ⁹⁾		Motor						Cover		Sensor system ¹⁰⁾	Auto- mation package	Docu- men- tation		
	Gear ratio	Mechanical inter- face	Motor code	Con- nec- tion		Hold- ing brake		Motor con- nec- tor posi- tion	Cover	Side seal- ing	Quantity: 1-6	Con- troller	Cables	Software	
F000									0 with- out		0 with- out				
F000 (without flange)			-	-	-	-	-	-	-						
F001									0 with- out		0 with- out				
F001 (with flange)			i = 1	MS2N06	MS2N06-B1BNN	1	-	Y	N	000					
					MS2N06-C0BTN					090					
					MS2N06-D0BRN					180					
					MS2N06-D1BNN					270					
S000									2 with		0 with- out				
S090															
S180															
S270															
S000 S090 S180 S270 (with belt side drive)			i = 1	MS2N06	MS2N06-B1BNN	1	-	Y	N	000					
					MS2N06-D1BNN					090					
					MS2N06-C0BTN					180					
			i = 2	MS2N06	MS2N06-C0BTN					270					

Flange	Motor connector position			
	0 °	90 °	180 °	270 °
F001	000	090 ★	180	270

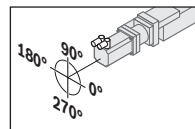

Example:
Flange F001
Motor connector
position 90°

Belt side drive	Motor connector position			
	0 °	90 °	180 °	270 °
S000	-	090	180 ★	270
S090	000	090 ★	180	-
S180	000 ★	090	-	270
S270	000	-	180	270 ★

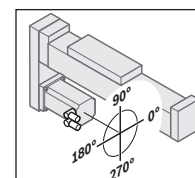

Example:
Timing belt side drive S270
Motor connector
position 180°





★ Standard delivery (connector position)

MKK-140-NN-3

Configuration and ordering

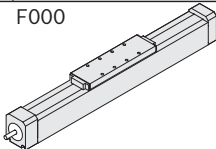
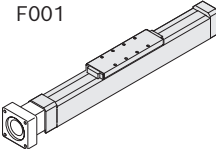
s _{max.} ¹⁾ (mm)	Material pairing ²⁾	Lubrica- tion ³⁾	Measuring system IMS- A ⁴⁾	Carriage ⁵⁾ (TT)		L _w (mm)	Guideway	Drive ⁷⁾			SPU ⁸⁾					
				T-slot (S) Thread (T) L _{ca} = 370 mm ⁶⁾	Number TT			Keyway	BASA	Tolerance grade						
s _{max} =	ALST (Aluminum/steel)	LSS	001 (HF)	S	1	-	104 with	0 without	40x5	T5	010 without SPU					
			002 (DQ)	T												
			000 without	S	2	L _w =	001 without					40x10	T7			
				T												
			LCF	-	S	1	-					004 with	1 with	40x5	T7	001 with SPU (1 pair)
					T											
	LCO															
	LPG															
	ALCR (Aluminum/hard chrome plated steel)	LSS	-	-	S	1	-	011 without	0 without	40x5	T7	002 with SPU (2 pair)				
					T											
					LCF											
					LCO											
LPG																

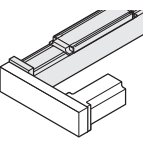
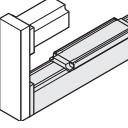
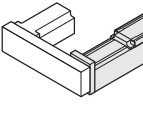
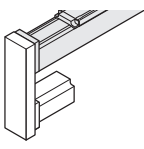
1) Travel range s_{max} depends on length L and option selection Length calculation ➡ Chapter "Project planning/calculation"
 2) Material pairing ➡ Chapter "Product description MKK-xxx-NN-3."
 3) Lubrication ➡ see chapter "Additional information".
 4) No SPU available for version with IMS
 5) Carriage version "2 TT" optionally available without screw support (SPU).
 6) Carriage with measuring system, L_{ca} = 500 mm
 7) Drive journal with keyway only available with F000 version!
 8) SPU only possible for carriage version "1 TT"!
 9) Attachment kit also available without motor.
 Mounting kits according to customer specification ➡ Chapter "Motor attachment kits according to customer specification".
 10) Further switch mounting options ➡ Chapter "Switching system."

Version	Attachment interface ⁹⁾		Motor						Cover		Sensor system ¹⁰⁾	Automation package	Documentation		
	Gear ratio	Mechanical interface	Motor code	1 cable	2 cables	with	without	Motor connector position	Cover	Side sealing	Quantity: 1-6	Controller	Cables	Software	
			 <p>F000</p>												
F000 (without flange)			-	-	-	-	-	-	0	0	000 without sensor / 120 sensor (PNP NC); 121 sensor (NPN NC) 122 sensor (PNP NO); 123 sensor (NPN NO)		Chapter "Automation package"		001 standard; 002 friction torque 003 lead deviation; 005 positioning accuracy
 <p>F001</p>									with-out	with-out					
F001 (with flange)			i = 1	MS2N07	MS2N07-B1BNN	1	-	Y	N		000		0		
			MS2N07-C1BRN		090										
			MS2N07-D1BNN		180										
 <p>S000</p>  <p>S090</p>  <p>S180</p>  <p>S270</p>											0				
S000 S090 S180 S270 (with belt side drive)			i = 1	MS2N07	MS2N07-B1BNN	1	-	Y	N		000		1		
			MS2N07-C1BRN		090										
			MS2N07-D1BNN		180										
			i = 2	MS2N07	MS2N07-B1BNN						270				

Flange	Motor connector position			
	0 °	90 °	180 °	270 °
F001	000	090 ★	180	270

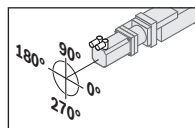

Example:
Flange F001
Motor connector position 90°

Belt side drive	Motor connector position			
	0 °	90 °	180 °	270 °
S000	-	090	180 ★	270
S090	000	090 ★	180	-
S180	000 ★	090	-	270
S270	000	-	180	270 ★

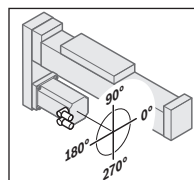

Example:
Timing belt side drive S270
Motor connector position 180°

★ Standard delivery (connector position)

Linear modules MKK

MKK-165-NN-2

Configuration and ordering

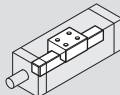
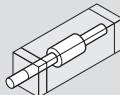
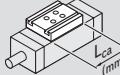
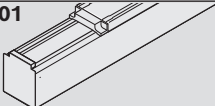
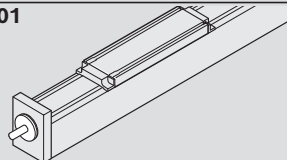
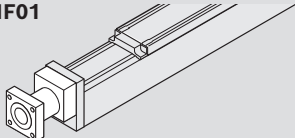
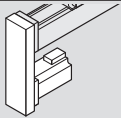
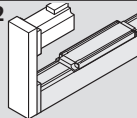
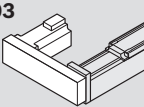
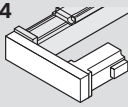
Short product name, length (L) Example: MKK-165-NN-2, (L) mm		Guideway	Drive				Carriage (TT)	
Version				BASA size d ₀ x P				 L _{ca} = 400 mm
				Screw journal	40x5	40x10	40x20	
without drive	OA01 	01		00				10
with BASA flangeless	OF01 	01	Ø 25	01	02	03	04	01
			Ø 25 with PF groove	11	12	13	14	
with BASA and flange	MF01 	01	Ø 25	01	02	03	04	01
with BASA and timing belt side drive	RV01 	01	Ø 25	01	02	03	04	01
	RV02 							
	RV03 							
	RV04 							

1) Flange and coupling or timing belt side drive for motor type according to customer specification, ➡ Chapter "Motor attachment kits according to customer specification".

2) Attachment kit also available without motor (when ordering: enter "00" for motor)

Length calculation ➡ Chapter "Project planning/calculation"

Motor attachment ¹⁾		Motor				Motor connector position	Cover	Switch/cable duct/socket-plug	Automation package	Documentation		
Gear ratio i =	Attachment kit ²⁾	Motor code	2 cables Brake		1 cable Brake		with- out PU Bellows		Controller	Cables	Software	
			with- out	with	with- out	with						
-	-	-	-				-	00 01	Without switch, without cable duct	00	Chapter "Automation package"	001 standard; 002 friction torque 003 lead deviation; 005 positioning accuracy
-	-	-	-					00 01	Switches: - PNP NC - PNP NO - Mechanical	11 13 15		
1	03	MS2N07-C0BQN	-	-	259	260	000	00 01	Cable duct (loose)	20		
		MS2N07-C1BRN	-	-	263	264				17		
1	25	MS2N07-C1BRN	-	-	263	264	090	00 01	External switching cam	16		
		MS2N07-C0BQN	-	-	259	260	180					
2	26	MS2N07-C0BQN	-	-	259	260	270					
		MS2N07-C1BRN	-	-	263	264						

Flange	Motor connector position			
	0 °	90 °	180 °	270 °
MF01	000	090 ★	180	270

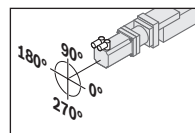

Example:
Flange MF01
Motor connector position 90°

Belt side drive	Motor connector position			
	0 °	90 °	180 °	270 °
RV01	-	090	180 ★	270
RV02	000	090 ★	180	-
RV03	000 ★	090	-	270
RV04	000	-	180	270 ★

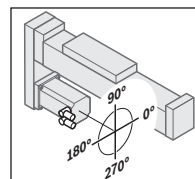

Example:
Belt side drive RV01
Motor connector position 180°

★ Standard delivery (connector position)

Dimension drawings MKK-040/-065/-080/-110/-140/-NN-3

Frame

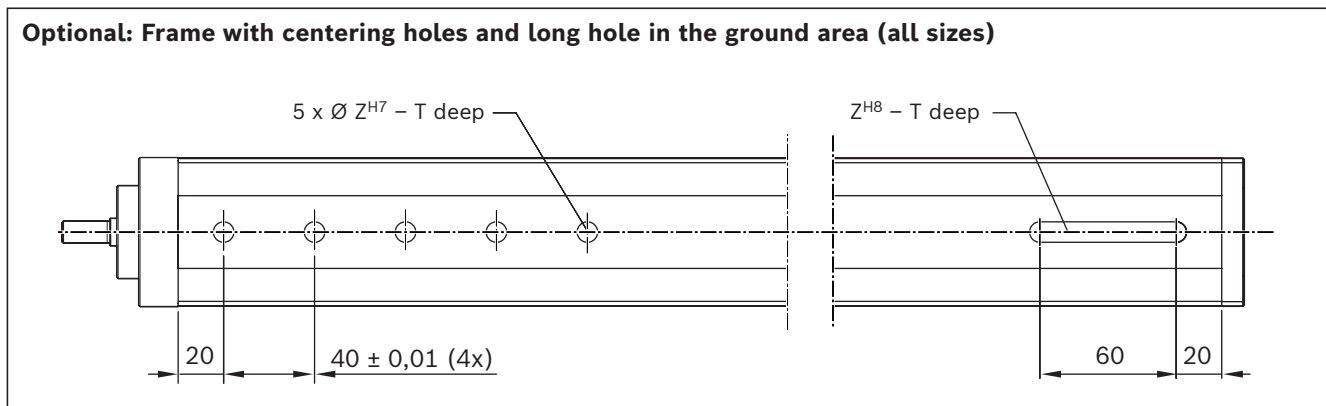
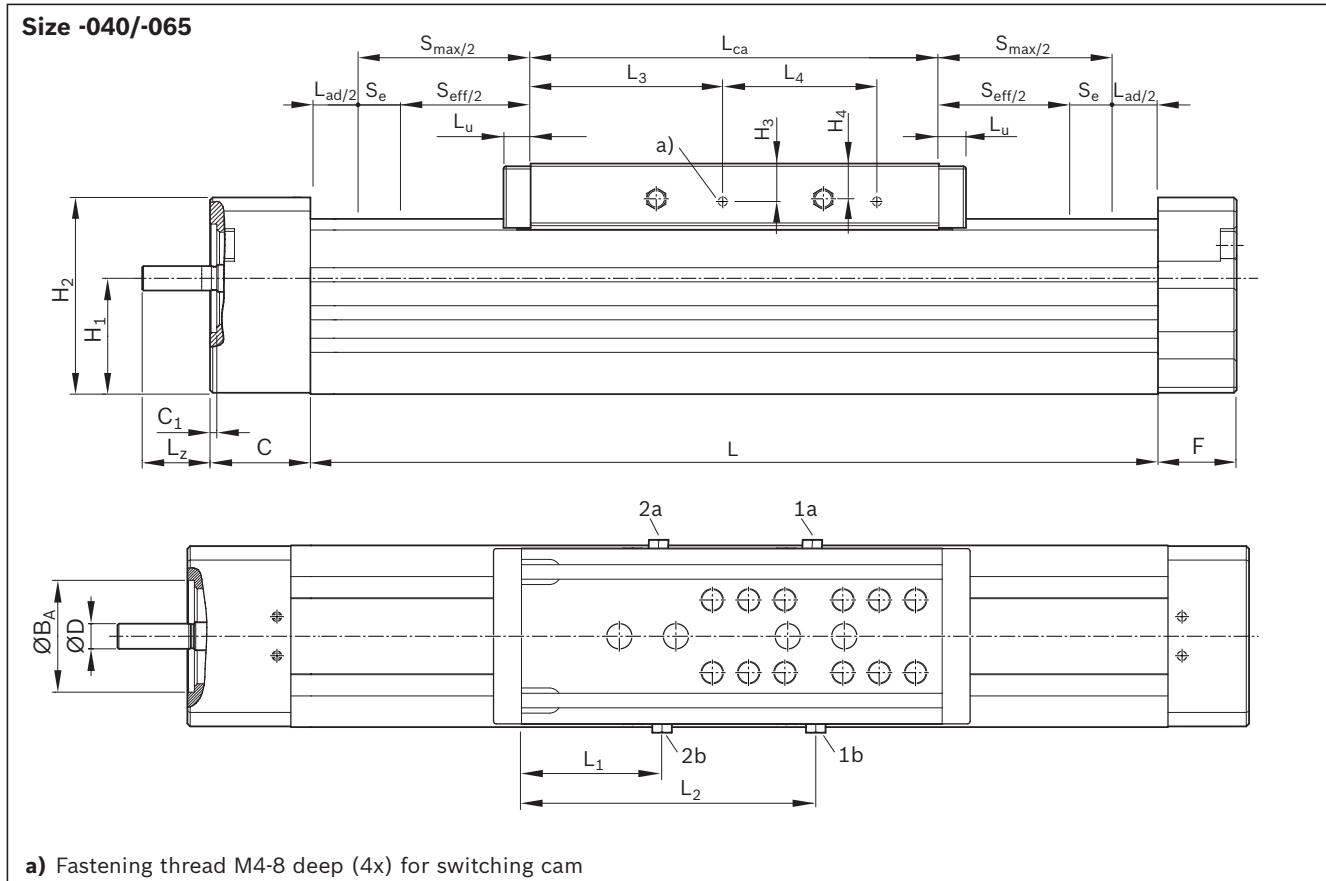

MKK	Dimensions (mm)																			
	B	B _S	$\varnothing B_A$ H7/h7	C	C ₁	$\varnothing D$ h7	E ₁	E ₂	F	H	H ₁	H ₂	H ₃	H ₄	L ₁	L ₂	L ₃	L ₄	L _{ca}	L _u
-040-NN-3	40	-	28	25	2.5	6	23	33	17	52	25.0	48.0	3.7	8.0	75.0	86.85	20.0	27	135	6.5
-065-NN-3	65	-	40	37	2.5	9	28	40	29	85	42.7	72.5	14.0	13.0	59.5	134.25	84.0	70	190	10.0
-080-NN-3	80	-	55	29	13.0	10	50	66	13	100	57.5	100.0	12.0	12.7	76.5 ¹⁾	175.00	88.0	70	260	30.0
-110-NN-3	110	85	68	29	16.0	16	46	90	16	129	78.0	133.0	16.0	16.0	120.5	224.60	137.5	70	305	35.0
-140-NN-3	140	105	80	63	4.0	25	65	100	14	170	98.5	161.0	19.0	23.0	141.0	266.70	35.0	70	370	35.0

L_{ad} = additional length ➡ Chapter "Technical data"

¹⁾ for BASA 20 x 40: Dimension $L_1 = 70$

See following pages for dimension drawings for carriages and motor attachment.

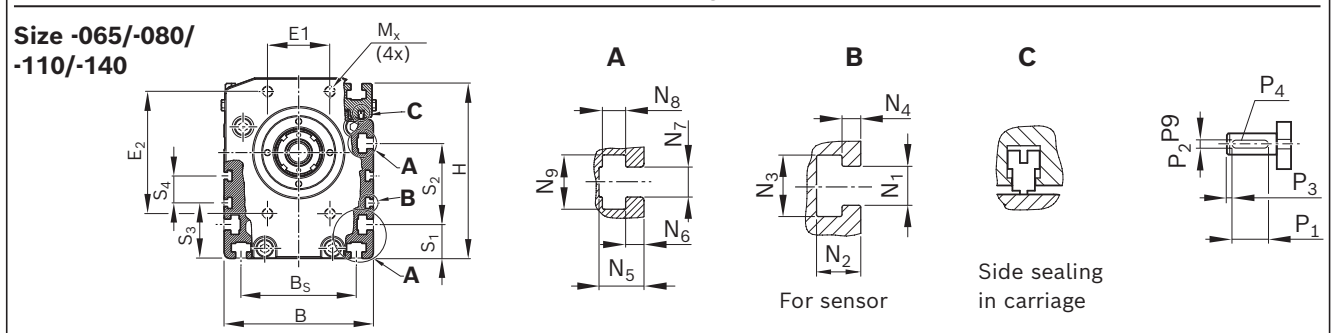
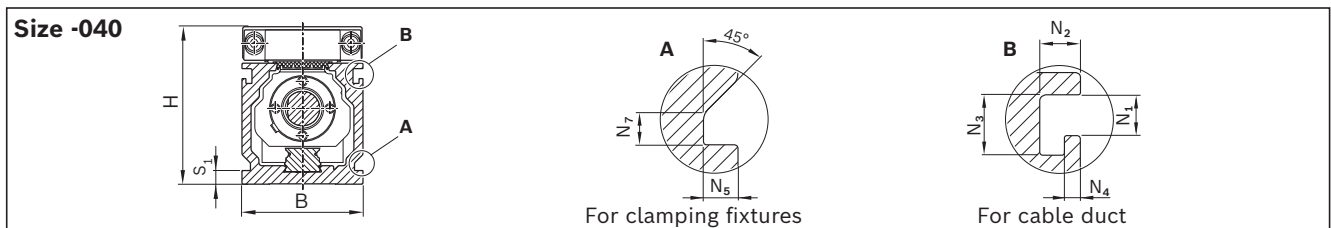
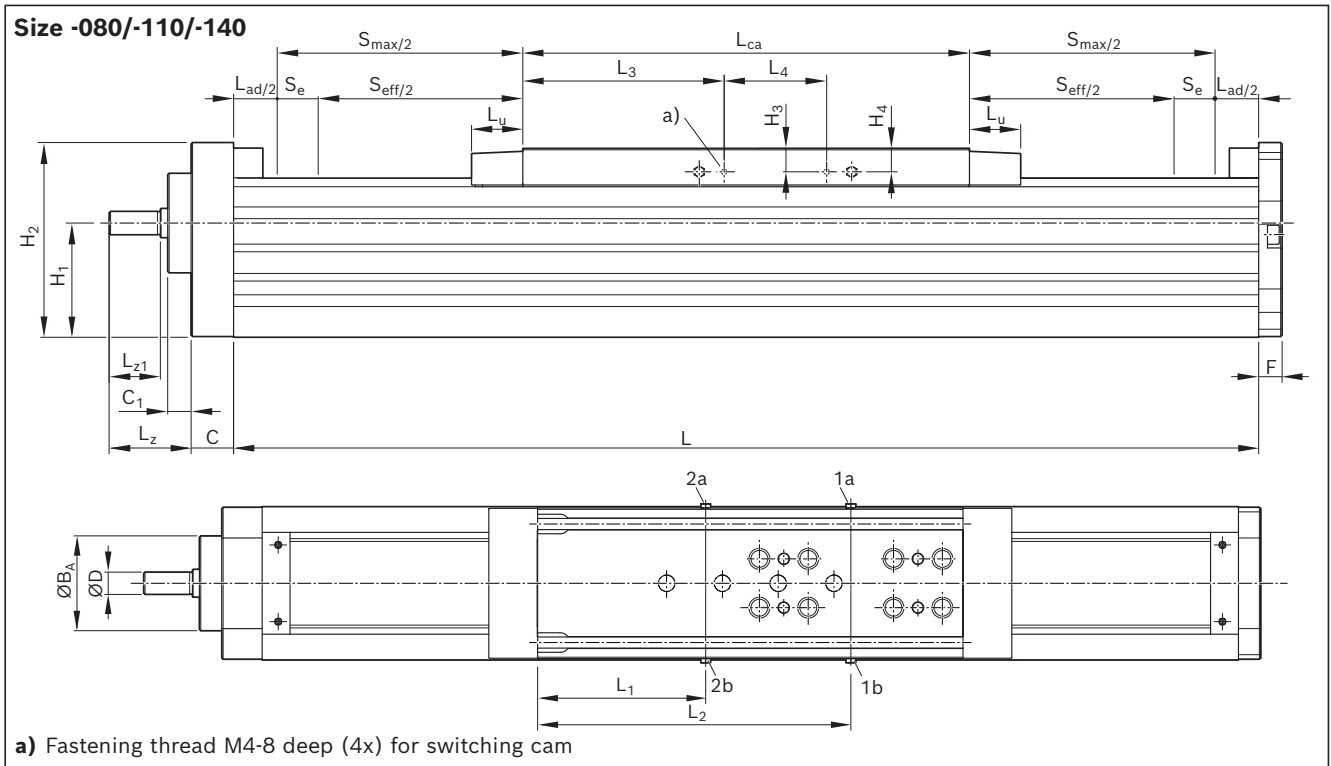

L_z	L_{z1}	M_x	Sliding block	N_1	N_2	N_3	N_4	N_5	N_6	N_7	N_8	N_9	P_1	P_2	P_3	P_4 deep	S_1	S_2	S_3	S_4	T	Z
18	-	M4-8 deep	-	3.3	3.3	4.9	1.3	2.8	-	2.5	-	-	-	-	-	4.5	-	36.5	-	1.6	7	
25	-	M6-14 deep	DIN557-M5	5.2	5.9	8.2	2.5	8.5	2.5	5.2	5.0	9.0	20	3	2.5	1.8	18.0	26	30.0	-	2.1	9
40	27	M8-18 deep	DIN557-M5	5.2	5.9	8.2	2.5	8.5	2.5	5.2	5.0	9.0	20	3	2.5	1.8	18.0	45	31.0	-	2.1	9
56	35	M8-18 deep	DIN508-M6	5.2	5.9	8.2	2.5	12.0	4.9	8.0	6.2	14.5	28	5	3.5	3.0	25.0	60	41.0	20	2.1	12
73	69	M10-20 deep	DIN508-M8	5.2	5.9	8.2	2.5	15.0	7.0	10.0	7.0	17.0	40	8	5.0	4.0	37.5	70	57.0	68	3.1	16

1a / 1b lube connection for ball runner block: lubrication on either of the two connections.
 2a / 2b lube connection for Rexroth ball screw assembly: lubrication on either of the two connections.
 (Lube connection 1a / 1b / 2a / 2b: funnel-type lube nipple DIN 3405-A M6; Size -040: DIN 3405-A M3)
 For further information, see chapter "Lubrication."

MKK-040/-065/-080/ -110/-140/-NN-3

Carriage dimension drawings

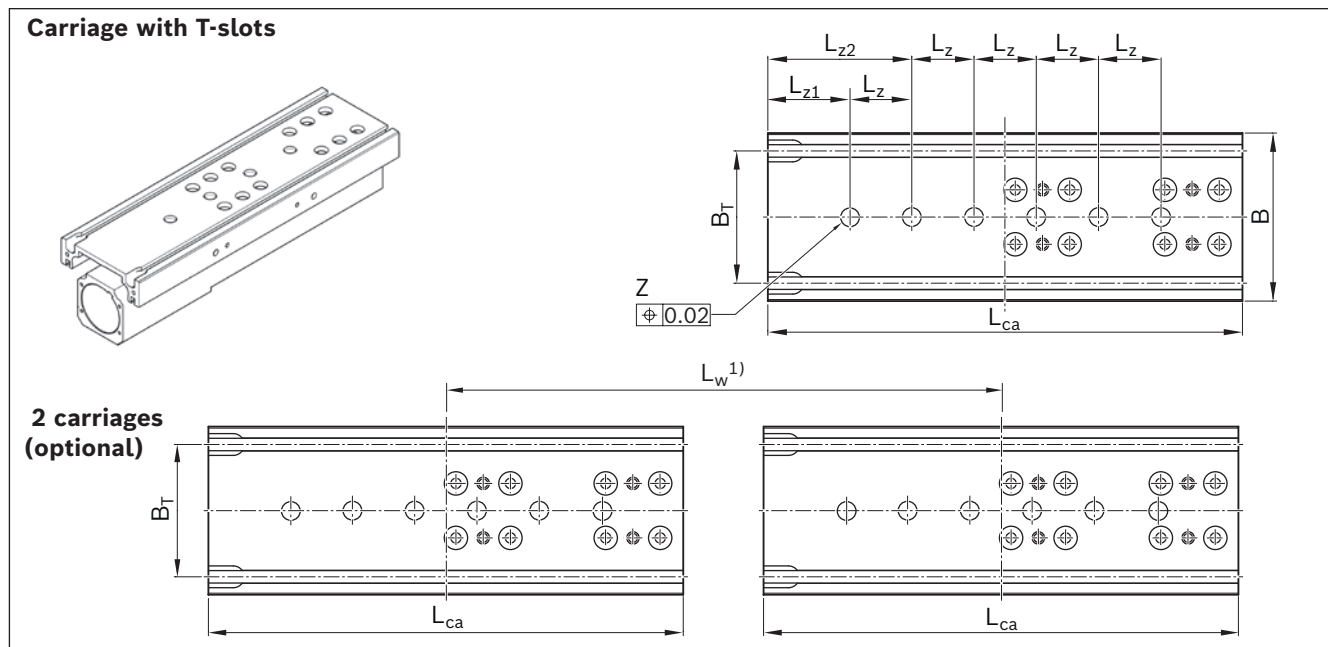
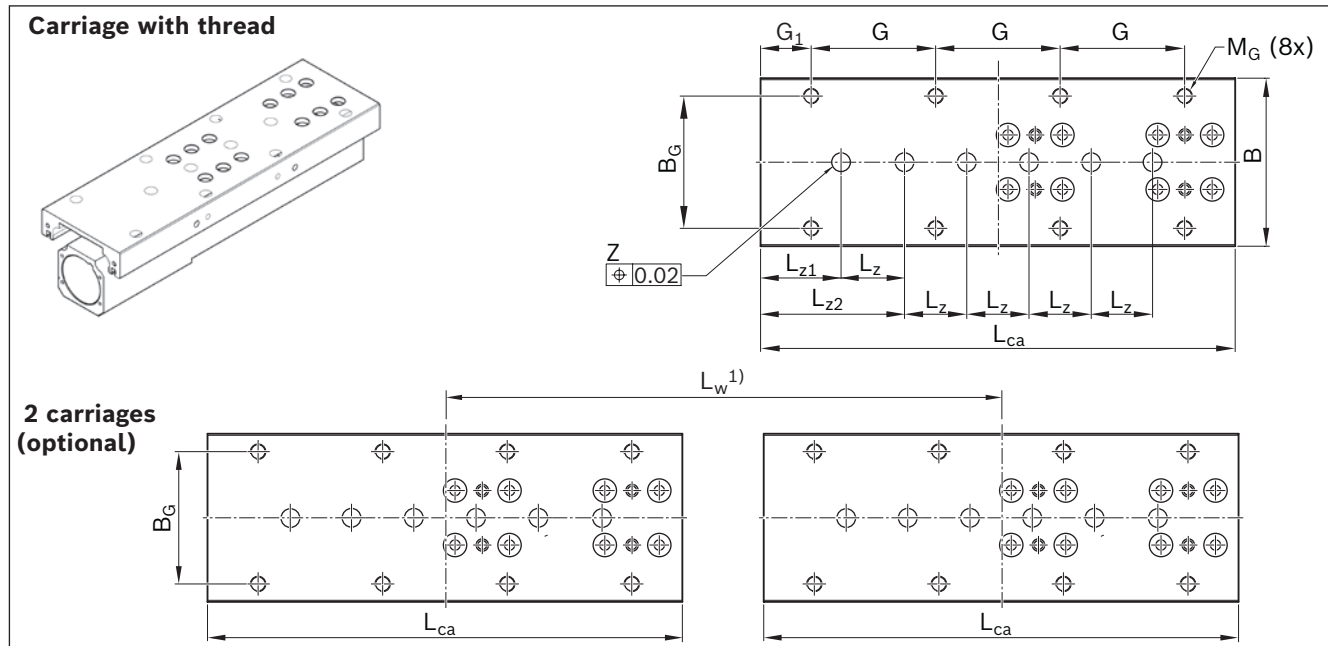

MKK	Dimensions (mm)														
	B	B _G	B _{IMS}	B _T	G	G ₁	H _{IMS}	L _{ca}	L _{ca IMS} ²⁾	L _{w min}	L _{w max}	L _z	L _{z1}	L _{z2}	M _G
-040-NN-3	39.5	30	-	-	25	30.0	-	135	-	-	-	20	-	37.5	M4-9 deep
-065-NN-3	63.0	46	-	46	50	20.0	-	190	-	210	750	40	-	35.0	M6-9 deep
-080-NN-3	78.0	60	126	60	70	25.0	6.5	260	360	320	960	40	-	70.0	M8-10 deep
-110-NN-3	108.0	85	156	85	80	32.5	8.0	305	430	375	1,095	40	-	92.5	M10-12 deep
-140-NN-3	138.0	105	186	105	105	27.5	11.0	370	500	450	1,350	40	85	-	M10-20 deep

¹⁾ Variable center-to-center distance defined by customer-built attachment.
Centerline-to-centerline distance freely selectable between minimum and maximum distance in millimeters steps.
²⁾ Clamping surface corresponds to L_{ca}
³⁾ Non-usable clamping surface

Carriage with thread and IMS

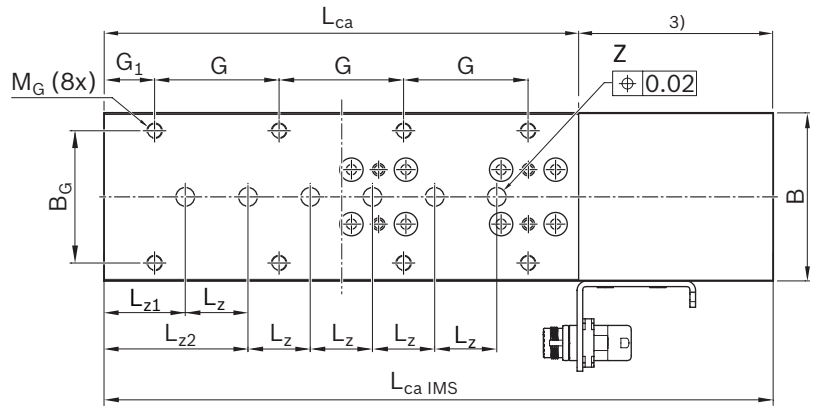
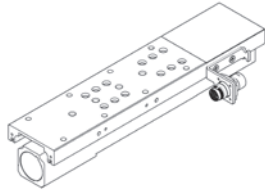

Carriage with T-slots and IMS

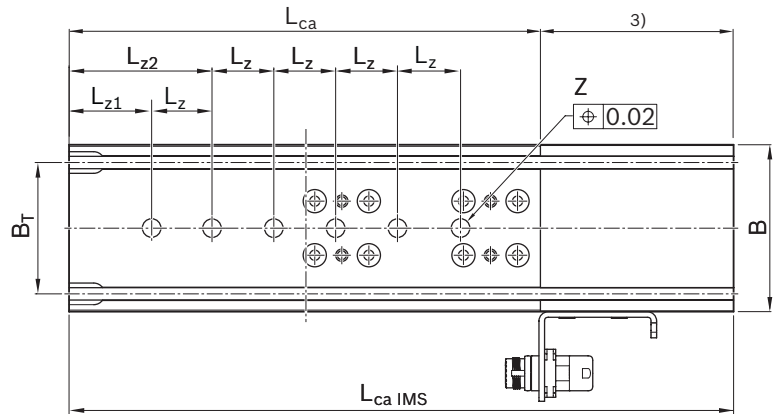
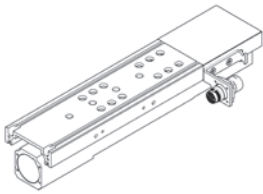

T-slots

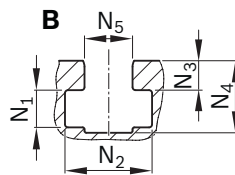
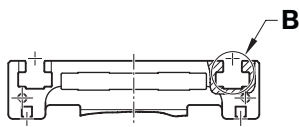

IMS connector

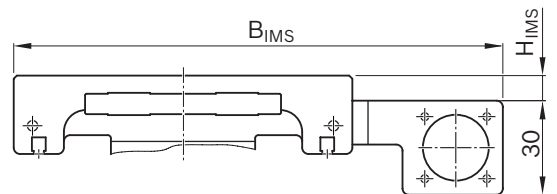

Sliding block	N ₁	N ₂	N ₃	N ₄	N ₅	Z
-	-	-	-	-	-	4 x Ø 7H7-1.6 deep
DIN557-M5	5.0	9.0	2.5	8.5	5.2	4 x Ø 9H7-2.1 deep
DIN557-M5	5.0	9.0	2.5	8.5	5.2	4 x Ø 9H7-2.1 deep
DIN508-M6	6.2	14.5	4.9	12.0	8.0	4 x Ø 12H7-2.1 deep
DIN508-M8	7.0	17.0	7.0	15.0	10.0	6 x Ø 16H7-3.1 deep

MKK-040/-065/-080/ -110/-140/-NN-3

Motor attachment dimension drawings

Motor attachment via flange and coupling

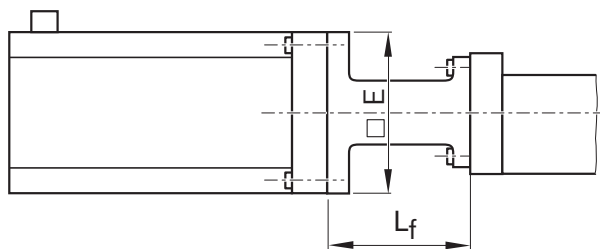

MKK	Motor code	Dimensions (mm)	
		□ E	L _f
-040-NN-3	MS2N03-BOBYN	see dimension □ A ➡ Chapter "Motors"	50.0
	MSM019B-0300		45.0
	MSM031B-0300		50.0
-065-NN-3	MSM041B-0300		83.0
	MS2N04-C0BTN		77.5
-080-NN-3	MSM041B-0300		90.0
	MS2N04-B0BTN		
	MS2N04-C0BTN		
	MS2N04-D0BQN		
-110-NN-3	MS2N05-B0BTN		115.0
	MS2N06-B1BNN		125.0
	MS2N06-C0BTN		
	MS2N06-D0BRN		
MS2N06-D1BNN			
-140-NN-3	MS2N07-B1BNN	140.0	
	MS2N07-C1BRN		
	MS2N07-D1BNN		

Further information about motors ➡ Chapter "Motors"

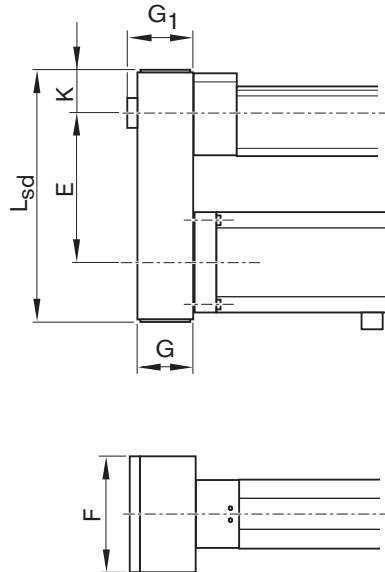
Motor attachment via belt side drive

MKK	Motor code	Dimensions (mm)								
		i = 1	i = 1.5	i = 2	E	F	G	G ₁	K	L _{sd}
-040-NN-3	MS2N03-B0BYN	78	75	-		64.5	37.0	43.5	33.5	154
	MSM019B-0300	76.5		-		48.0	27.5	29.0	27.5	140
	MSM031B-0300	78	75	-		64.5	37.0	43.5	33.5	157
-065-NN-3	MSM041B-0300	122		-		88.0	51.0	57.0	45.5	231
	MS2N04-B0BTN	122		-		88.0	51.0	-	47.5	231
-080-NN-3	MSM041B-0300	122		-		88.0	51.0	-	47.5	231
	MS2N04-C0BTN	122		-		88.0	51.0	-	47.5	231
	MS2N04-D0BQN	122	-	-		88.0	51.0	-	47.5	231
	MS2N04-B0BTN	-	122	-		88.0	51.0	-	47.5	231
	MS2N05-C0BTN	155	-	-		116.0	66.0	-	56.0	287
-110-NN-3	MS2N05-D0BRN	-	-	155		116.0	66.0	-	56.0	287
	MS2N06-B1BNN	165	-	-		116.0	66.0	-	58.5	300
	MS2N06-D1BNN	-	-	162		116.0	66.0	-	58.5	300
-140-NN-3	MS2N06-C0BTN	-	-	162		116.0	66.0	-	58.5	300
	MS2N07-B1BNN	240	-	238		160.0	90.0	-	77.0	409
	MS2N07-C1BRN	240	-	238		160.0	90.0	-	77.0	409
	MS2N07-D1BNN	240	-	238		160.0	90.0	-	77.0	409

Further information about motors ➔ Chapter "Motors"

MKK-165-NN-2

Dimension drawings

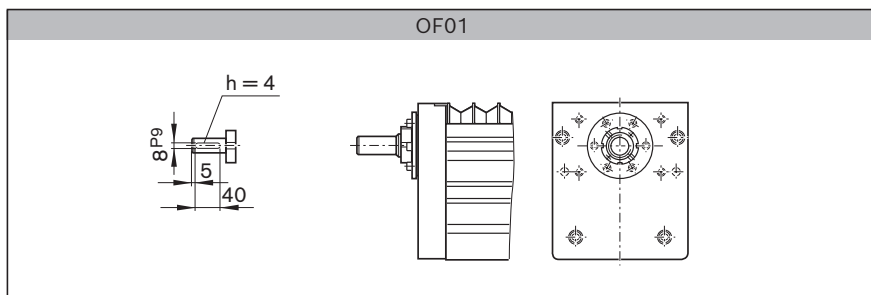
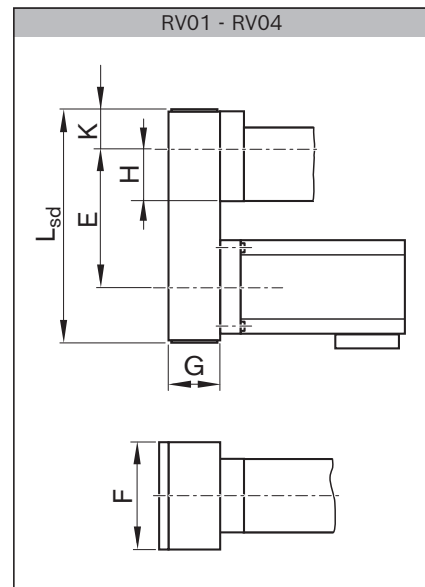
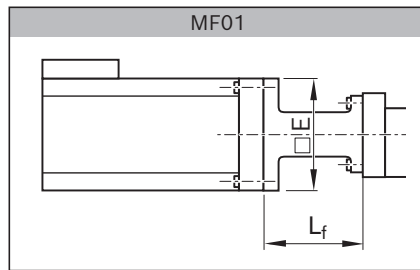
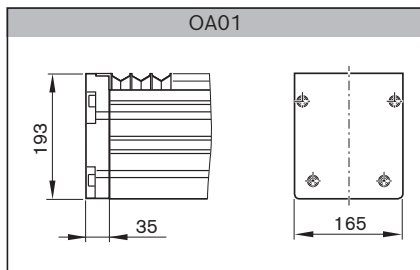
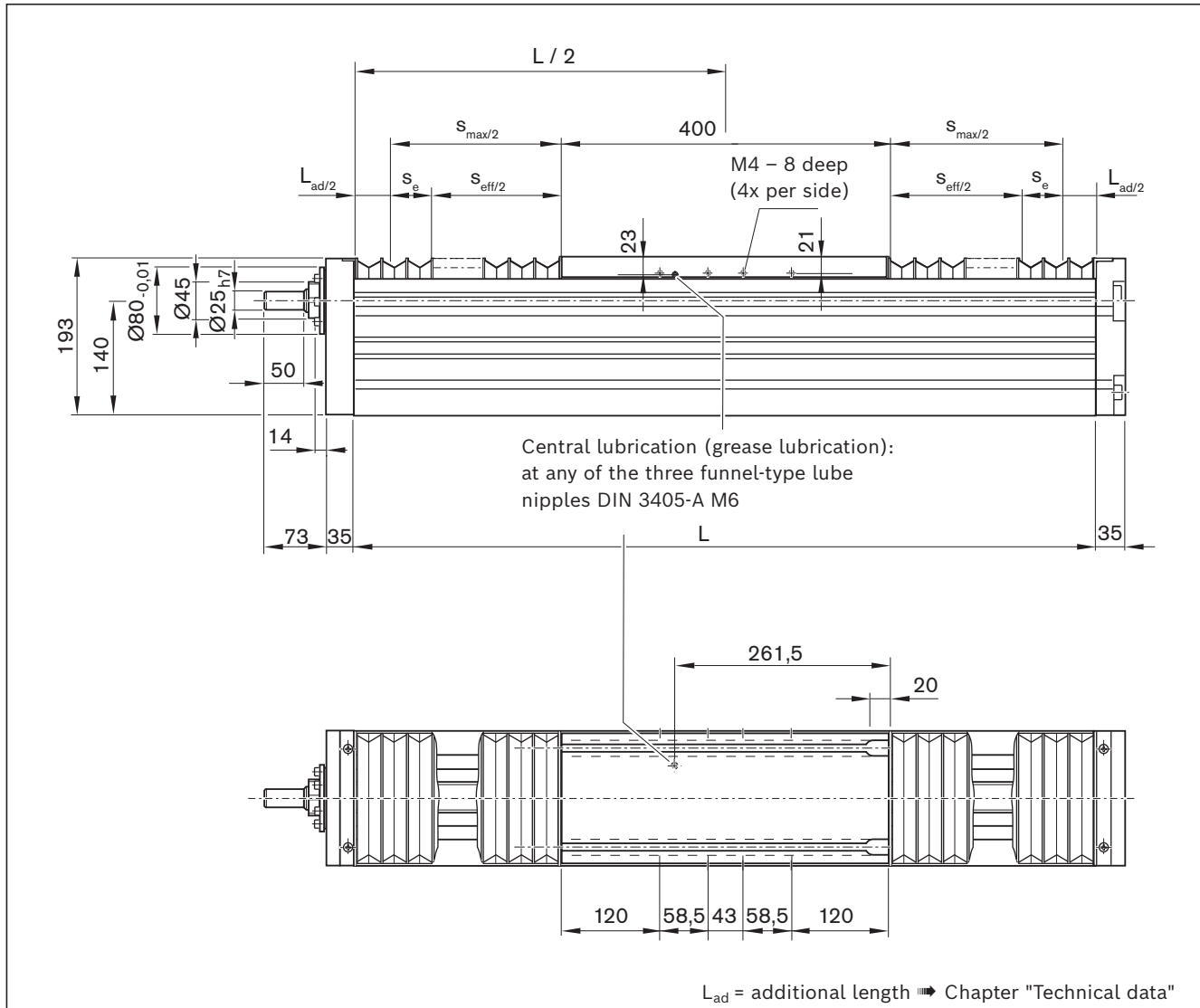

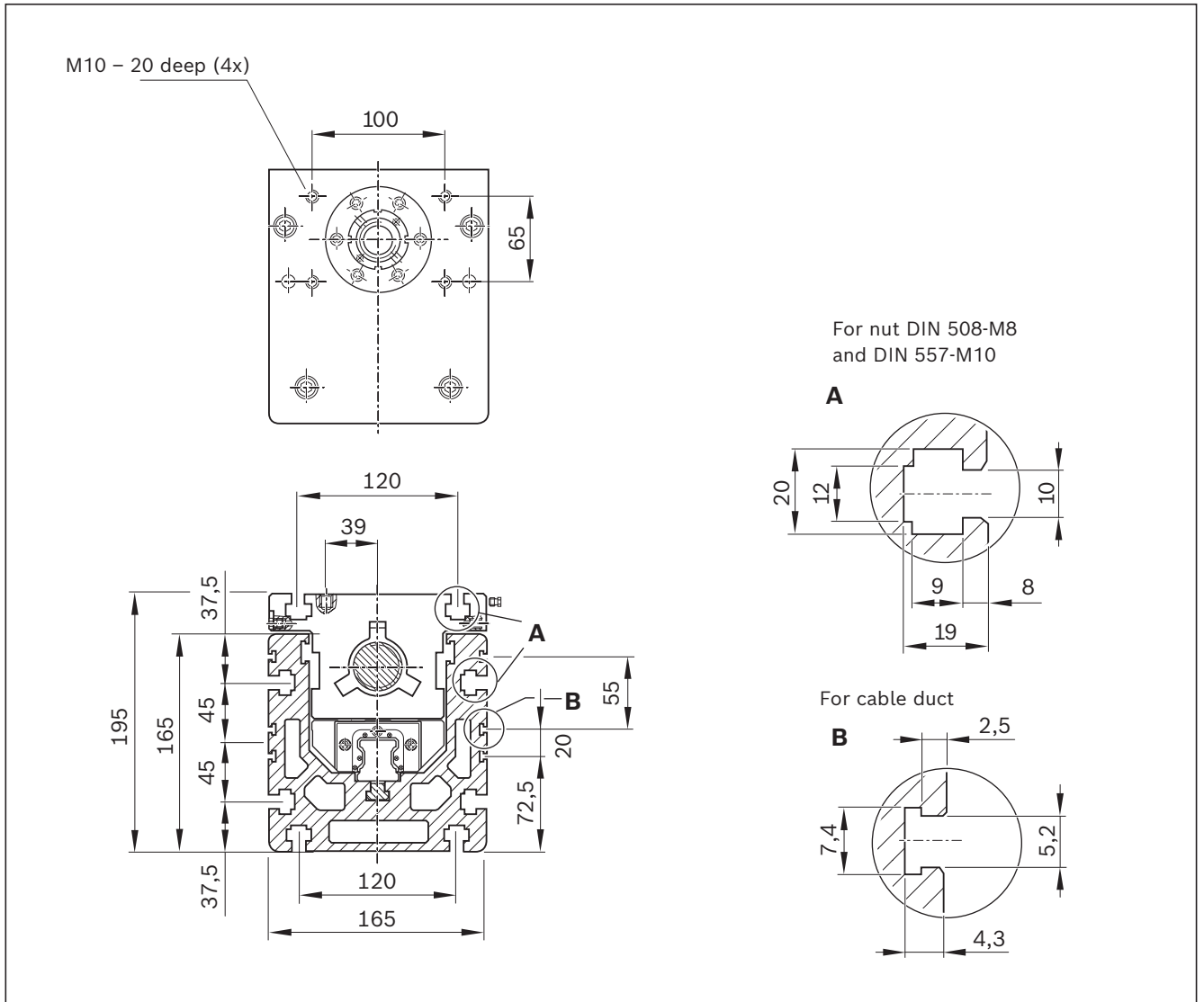

Version	Motor code	Dimensions (mm)			□ E	L _f	F	G	H	K	L _{sd}
		i = 1	i = 1.5	i = 2							
RV01 - RV04	MS2N07-C0BQN	240	-	238	-	-	160	90	140	77	409
	MS2N07-C1BRN			238							
	MS2N07-D0BRN			238							
	MS2N07-E0BQN			-							
MF01	MS2N07-C0BQN	-	-	-	1)	148	-	-	-	-	-
	MS2N07-C1BRN										
	MS2N07-D0BRN										
	MS2N07-E0BQN										

1) see dimension □ A ➔ Chapter "Motors"

Further information about motors ➔ Chapter "Motors"

Product description MKR-xxx-NN-3

Features

- Ready-to-install linear modules in any length up to L_{\max}
- Realization of greater lengths of up to 9,800 mm
- Extremely compact aluminum profile with integrated Rexroth ball rail system with moderate preload (preload class C1)
- High travel speed combined with the wear-resistance typical of rolling-element high precision over long lengths
- High-performance toothed belt in the largest possible overall width for high drive torques with simultaneously high rigidity
- Carriages made of aluminum, in two design versions, with T-slots or threaded holes and with centering holes in each case
- Protection of the guide and drive components by sealing strip (plastic strip for MKR-040/-065, corrosion-resistant steel strip for MKR-080/-110/-140)
- Economical maintenance thanks to the one-point lubrication feature (grease lubrication or oil lubrication) from both sides via the carriage
- Repeatability of up to ± 0.05 mm

Further highlights

- Available in two material versions, ALST (aluminum/steel version) and ALCR (aluminum/steel hard chrome plated version)
- Centering holes also in the frame profile for simple combination with other linear systems and connection elements
- Absolute length measuring system IMS-A directly integrated into the guide system (MKR-080/-110/-140)
- Standard with integrated solenoid switch for magnetic field sensors
- Extensive accessories range of connection and clamping units and connecting shafts
- Nameplate with parameters for easy commissioning
- Special version: Profile frame also interconnectable as multiple parts for lengths $> L_{\max}$ (on request)

Attachments

- Planetary gear with various gear ratios
- Attachment kits for motor according to customer specification
- Servo motor
- Magnetic field sensors for easy assembly directly on the profile frame
- Switch (proximity or mechanical) cable duct, socket-plug and extension cables in the accessories program

Example variants

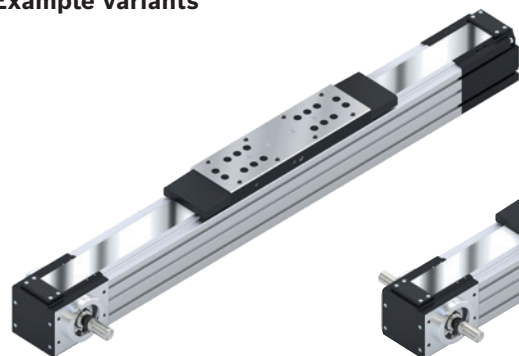

**One drive journal,
long carriage with thread**

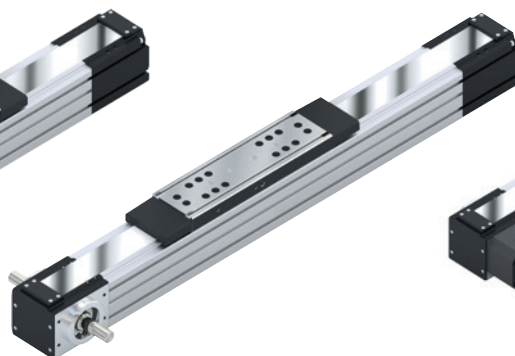

**Two drive journals,
long carriage with T-slots**



**Planetary gear with motor,
long carriage with T-slots**

Material pairing

ALST:

- Frame, carriage and end enclosures made of anodized aluminum (AL)
- MKR-065/-080/-110/-140/-145: Ball guide rail and ball runner block made of anti-friction bearing steel (ST)
- MKR-040: Ball guide rail and ball runner block of rust and acid resistant material
- Deep-groove ball bearing of the drive mechanism (belt pulleys) made of anti-friction bearing steel

ALCR:

- Frame, carriage and end enclosures made of anodized aluminum (AL)
- MKR-065/-080/-110/-140/-145: Ball guide rail made of anti-friction bearing steel with corrosion-resistant coating, matte-silver finish, hard chrome plated (Resist CR). ball runner block made of corrosion-resistant steel (Resist NR)
- MKR-040: Ball guide rail and ball runner block of rust and acid resistant material
- Deep-groove ball bearing of the drive mechanism (belt pulleys) made of anti-friction bearing steel

Lubrication versions

LSS: (Initial lubrication done at the factory)

- Initial standard greasing done at the factory, suitable for normal environmental conditions.
- Simple relubrication via manual grease gun.

MKR-065/-080/-110/-140/-145:

- Grease Dynalub 510, lithium-based high-performance grease of grade NLGI 2 according to DIN 51818 (KP2K-20 according to DIN 51825)

MKR-040:

- Grease lubricant Dynalub 520, lithium-based high-performance grease of grade NLGI 00 according to DIN 51818 (GP00K-20 according to DIN 51826)

LPG: (Corrosion prevention, no initial lubrication)

- Linear module without initial greasing done at the factory.
- Ball rail System, only with corrosion prevention.
- Basic lubrication required

LCF: (prepared for connection to central lubrication systems with liquid grease)

- for liquid grease, lithium-based high-performance grease of grade NLGI 00 according to DIN 51818 (GP00K-20 according to DIN 51826)
- Only use liquid grease lubrication with single-line total-loss lubrication systems via piston distributors.
- Basic lubrication required

LCO: (prepared for connection to central lubrication systems with oil)

- ball runner block with integrated non-return valves
- Only use oil lubrication with single-line total-loss lubrication systems via piston distributors.
- Basic lubrication required

Product description for integrated measuring system

The IMS-A measuring system offers the following advantages:

- No additional space required.
- No additional mounting surfaces required for the measuring system.
- No measurement inaccuracies due to parallelism offset between the measuring system and the guide system.
- Full integration of the measuring system components into the guide means no complex mounting or tuning work is needed.
- The runner block, scanner and guide rail with scale can be replaced individually during servicing.
- Interfaces: HIPERFACE (HF) or DRIVE-CLiQ (DQ).
- Connecting cable directly on the side of the carriage.
- For further information, see the "Integrated Measuring System" chapter

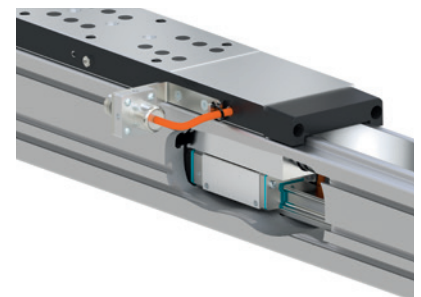

Linear modules MKR

Product description MKR-165-NN-2

Features

Linear modules with ball rail system and toothed belt drive for high speeds and high demands on the guideway. The integrated, backlash-free Rexroth ball rail system makes it possible for large masses to be moved at high speed thanks to high load capacities and optimal travel performance.

The Linear modules comprise:

- A compact anodized aluminum frame
- The integrated Rexroth ball rail system
- A carriage with T-slots for fixtures, with central lubrication point
- High-performance toothed belt (AT profile)
- A cover provided by the toothed belt
- Mountable switches
- Servo motor
- Gear reducer for motor attachment

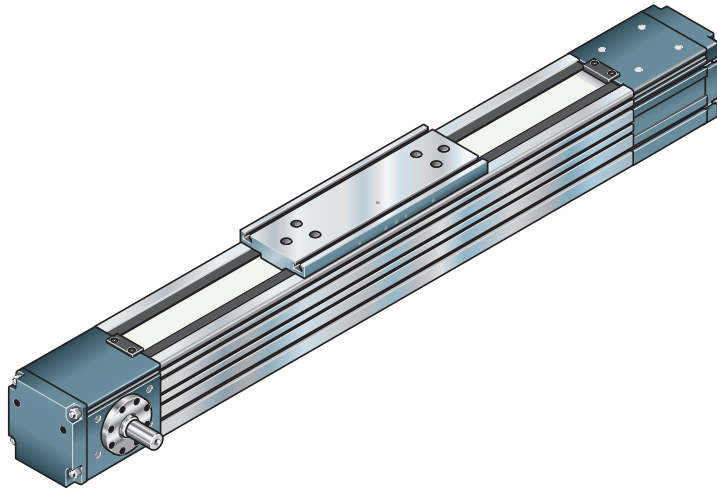

Structural design

Structural design

- 1 Drive side end enclosure
- 2 Toothed belt (covered)
- 3 Carriage with runner block
- 4 Sealing strip for MKR-040/-065/-080/-110/-140
- 5 Strip fixing for MKR-040/-065/-080/-110/-140
- 6 Idler end enclosure
- 7 Frame

Attachments:

- 8 Cable duct
- 9 Switching cam
- 10 Proximity switch
- 11 Mechanical switch
- 12 Socket/connector
- 13 Magnetic field sensor

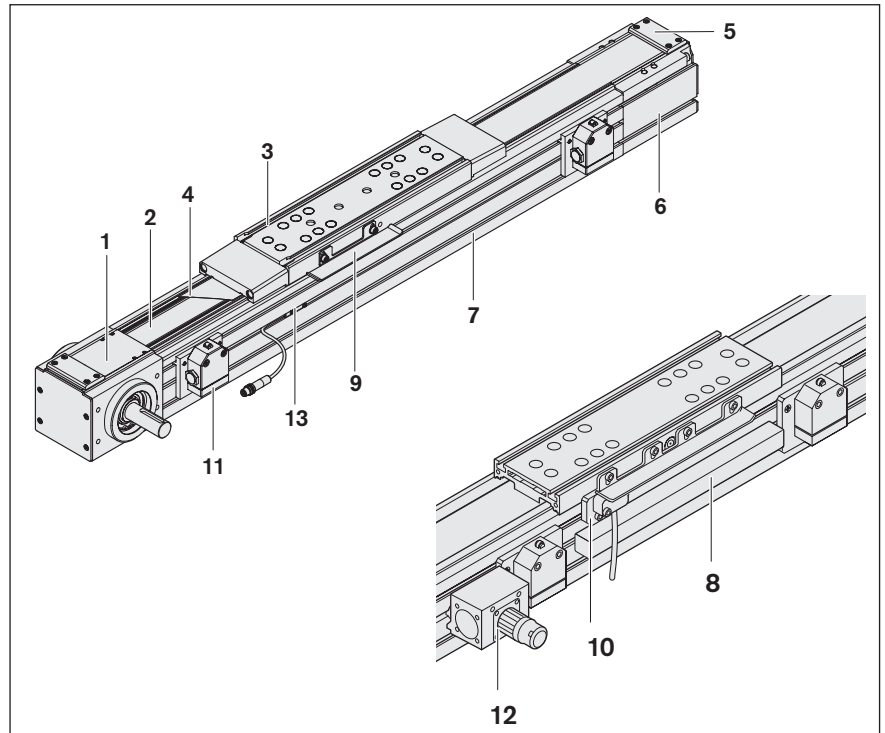

Versions

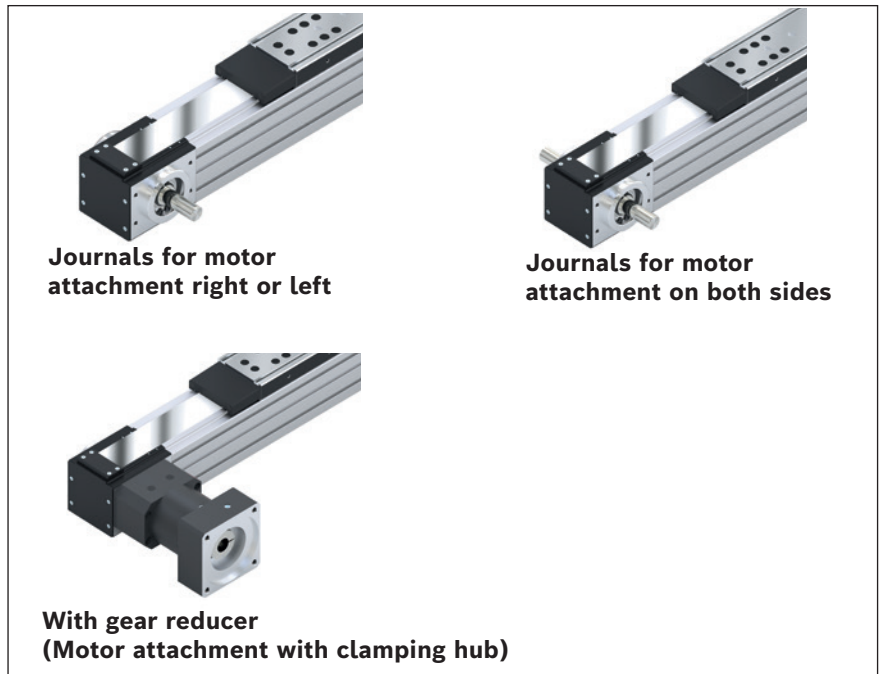

Carriage variants MKR-xxx-NN-3

For further information, see the chapter on "Carriage dimension drawings"

Carriage (TT) with T-slots		with threads	
short (S)	long (L)	short (S)	long (L)

Linear modules MKR

Technical data

General technical data

Observe the chapter "Project planning/calculation"!

MKR	Carriage length		Dynamic characteristic values			Maximum permissible loads						Moved mass of system m_{ca} (kg)
	L_{ca} (mm)	$L_W^{1)}$ (mm)	C_{gw} (N)	M_t (Nm)	$M_L^{2)}$ (Nm)	Torques			Forces			
						$M_{x \max}$ (Nm)	$M_{y \max}^{3)}$ (Nm)	$M_{z \max}^{3)}$ (Nm)	$F_{y \max}$ (N)	$F_{z1 \max}$ (N)	$F_{z2 \max}$ (N)	
-040-NN-3	135	–	3,750	22.3	129.5	11	65	65	1,875	1,875	1,875	0.29
-065-NN-3	190	–	16,020	154	569	76	280	280	6,600	7,890	7,890	1.1
	2 x 190 (2 TT)	variable min = 234 max = 804	26,020	251	13 x L_W	152	7.9 x L_W	7.9 x L_W	15,775	15,775	15,775	2.2
-080-NN-3	190	–	23,400	300	200	120	80	80	9,360	9,360	9,360	1.4
	260	–	38,015	487	2,470	240	1,217	1,164	18,100	18,720	18,720	2.6
	2 x 260 (2 TT)	variable min = 404 max = 1004	61,755	792	30.9 x L_W	480	18.7 x L_W	18.7 x L_W	37,440	37,440	37,440	5.2
	360 (with IMS)		38,015	487	2,470	76	549	1,164	18,100	18,100	8,440	3.5
-110-NN-3	210	–	28,600	410	290	164	116	116	11,440	11,440	11,440	2.6
	305	–	46,460	666	2,790	328	1,373	1,373	22,880	22,880	22,880	4.1
	2 x 305 (2 TT)	variable min = 439 max = 1209	75,475	1,082	37.7 x L_W	656	22.9 x L_W	22.9 x L_W	45,760	45,760	45,760	8.2
	410 (with IMS)	–	46,460	666	2,790	116	662	1,373	22,880	22,880	11,040	4.9
-140-NN-3	370	–	59,300	1,023	4,151	260	1,414	2,044	28,800	28,800	20,200	8.0
	2 x 370 (2 TT)	variable min = 652 max = 2032	96,325	1,663	48.2 x L_W	520	20.2 x L_W	29.2 x L_W	58,400	58,400	40,400	16.0
	500 (with IMS)		59,300	1,023	4,151	260	1,414	2,044	28,800	28,800	20,200	9.8
-165-NN-2	400	–	84,100	1,800	5,130	340	1,281	2,528	41,440	41,440	21,000	11.5

¹⁾ Variable center-to-center distance defined by customer-built attachment.

Centerline-to-centerline distance between minimum and maximum distance in 5 mm steps, selectable in 10 mm steps on MKR-110 and in 15 mm steps on MKR-140.

²⁾ Determine the dynamic longitudinal load moment M_L with variable carriage centerline-to-centerline distance according to the selected centerline-to-centerline distance.

³⁾ Determine the maximum permissible longitudinal moments $M_{y \max}$ and $M_{z \max}$ at variable carriage centerline-to-centerline distance according to the selected centerline-to-centerline distance.

⁴⁾ Minimum required travel range to ensure a reliable lubrication distribution.

For operating conditions, see chapter "Additional information." If values are not met, please contact Bosch Rexroth.

⁵⁾ Maximum permissible length L_{\max} with measuring system (IMS)

Version / gear unit	Constant mass calculation		Additional length L_{ad} (mm)	Min. travel range $s_{min}^{4)}$ (mm)	Max. length L_{max} (mm)	Application point of the effective force z_1 (mm)	Planar moments of inertia						
	$k_g \text{ fix}$ (kg)	$k_g \text{ var}$ (kg/mm)					I_y (cm ⁴)	I_z (cm ⁴)					
0000	0.25	0.0025	10	50	2,500	34.5	10.53	14.78					
F010, F011	0.52	0.0027											
G010, G011	0.60												
0000	0.20	0.0066	94	60	5,900	49.0	76.40	93.70					
F010, F011, F020	2.40	0.0068	32										
G010, G011	2.70												
F010, F011, F020	2.40												
G010, G011	2.70												
G010, G011	2.70												
0000	0.25	0.0099	162	60	6,000 4,500 ⁵⁾	59.5	149.00	213.00					
F010, F011, F020	3.40	0.0102	17										
G010, G011	4.10												
0000	0.40	0.0099	162										
F010, F011, F020	3.40												
G010, G011	4.10	0.0102	17										
F010, F011, F020	3.40												
G010, G011	4.10												
F010, F011, F020	3.40												
G010, G011	4.10												
F010, F011, F020	3.40												
G010, G011	4.10												
G010, G011	4.10												
0000	0.30	0.0156	160						60	9,400 4,500 ⁵⁾	74.5	498.00	643.00
F010, F011, F020	6.80	0.0162	11										
G010, G011 (i = 3, i = 5)	7.40												
G010, G011 (i = 10)	7.60												
0000	0.40	0.0156	160										
F010, F011, F020	6.80												
G010, G011 (i = 3, i = 5)	7.40	0.0162	11										
G010, G011 (i = 10)	7.60												
F010, F011, F020	6.80												
G010, G011 (i = 3, i = 5)	7.40												
G010, G011 (i = 10)	7.60												
F010, F011, F020	6.80												
G010, G011 (i = 3, i = 5)	7.40												
G010, G011 (i = 10)	7.60												
F010, F011, F020	6.80												
G010, G011 (i = 3, i = 5)	7.40												
G010, G011 (i = 10)	7.60												
0000	0.55	0.0264	220	80	9,800 4,500 ⁵⁾	123.0	1,485.00	1,904.00					
F010, F011, F020	16.65	0.0269	27										
G010, G011	18.10												
F010, F011, F020	16.65												
G010, G011	18.10												
F010, F011, F020	16.65												
G010, G011	18.10												
G010, G011	18.10												
OA01	29.50	0.0384	40	80	12,000	123.0	2,479.00	3,540.00					
MA01 – MA03	29.50												
MG01, MG02 (i = 8)	36.00												
MG01, MG02 (i = 12, i = 16)	36.00												

Length calculation ➡ Chapter "Project planning/calculation"

Short product names ➡ Chapter "Abbreviations"

Linear modules MKR

Technical data

Drive data/gear data

Observe the chapter "Project planning/calculation"!

MKR	Gear type ¹⁾	Gear ratio <i>i</i> (-)	Max. acceleration torque (at the gear output)	Base frictional torque	Max. drive speed
			$M_{ge}^{2)}$ (Nm)	M_{Rge} (Nm)	$n_{ge}^{2)}$ (rpm)
-040-NN-3	PG040	5	14	0.10	18,000
		10	5	0.10	18,000
-065-NN-3	PG060	3	45	0.15	13,000
		5	64	0.10	13,000
		10	24	0.10	13,000
-080-NN-3	PG080	3	136	0.60	7,000
		5	176	0.50	7,000
		10	61	0.45	7,000
-110-NN-3	PG080	3	136	0.60	7,000
		5	176	0.40	
	PG120	3	184	1.20	6,500
		5	312	0.90	
		10	152	0.65	
-140-NN-3	PG120	5	312	0.90	6,500
		12 ³⁾	416	0.80	6,500
				0.95	
		16 ³⁾	416	0.80	6,500
0.95					
-165-NN-2	PG160	8	720	1.20	6,500
		12 ³⁾	1,280	2.10	
		16 ³⁾	1,280	2.20	

¹⁾ Planetary gear

²⁾ The limits of the linear motion system must not be exceeded. Further information about the calculation  Chapter "Project planning/calculation"

³⁾ Two-stage gear

	Motor	Mass moment of inertia	
		J_{ge} (kg/m ²)	m_{ge} (kg)
	MS2N03-D	0.0000065	0.60
	MSM031B	0.0000065	0.60
	MS2N03-D	0.0000062	0.60
	MSM031B	0.0000062	0.60
	MS2N03-D	0.0000128	0.90
	MS2N04	0.0000135	0.90
	MSM041B	0.0000369	1.20
	MS2N03-D	0.0000080	0.90
	MS2N04	0.0000100	0.90
	MSM031C	0.0000100	0.90
	MSM041B	0.0000347	1.20
	MS2N03-D	0.0000065	0.90
	MS2N04	0.0000085	0.90
	MSM031C	0.0000085	0.90
	MSM041B	0.0000345	1.20
	MS2N06	0.0001521	3.00
	MS2N05	0.0001521	2.80
	MSM041B	0.0001521	2.00
	MS2N06	0.0001290	3.00
	MS2N05	0.0001290	2.80
	MSM041B	0.0001290	2.00
	MS2N06	0.0001246	3.00
	MS2N05	0.0001246	2.80
	MSM041B	0.0001246	2.00
	MS2N06	0.0001520	3.00
	MS2N06	0.0001290	3.00
	MS2N07	0.0004723	7.40
		0.0003995	7.40
	MS2N06	0.0001378	6.20
	MS2N07	0.0003744	7.40
	MS2N07	0.0003995	7.40
	MS2N06	0.0002220	8.20
	MS2N07	0.0004586	9.40
	MS2N06	0.0001740	8.20
	MS2N07	0.0004108	9.40
	MS2N07	0.0004630	18.00
		0.0012400	22.00
		0.0007500	22.00

Linear modules MKR

Technical data

Drive data/gear data

Observe the chapter "Project planning/calculation"!

MKR	Gear ratio i (-)	Max. drive torque M_P (Nm)	Feed constant u (mm/rev)	Max. speed v_{max} (m/s)	Carriage L_{ca} (mm)	
-040-NN-3	1 ¹⁾	4.50	90.0	3.0	135	
	5 ²⁾	0.90	18.0	3.0	135	
	10 ²⁾	0.45	9.0	2.7		
-065-NN-3	1 ¹⁾	12.00	125.0	5.0	190	
	1 (with keyway) ³⁾			5.0	2 x 190	
	3 ²⁾	4.00	41.7	5.0	190	
	5 ²⁾	2.40	25.0	5.0	2 x 190	
	10 ²⁾	1.20	12.5	2.7		
-080-NN-3	1 ¹⁾	36.00	205.0	5.0	190	
	1 (with keyway) ³⁾				260	
	3 ²⁾	360 (with IMS)				
		2 x 260				
		190				
		260				
5 ²⁾	7.20	41.0	4.7	360 (with IMS)		
10 ²⁾	3.60	20.5	2.4	2 x 260		
-110-NN-3	1 ¹⁾	100.00	290.0	5.0	210	
	1 (with keyway) ³⁾				305	
	3 ²⁾	410, (with IMS)				
		2 x 305				
		210				
		305				
5 ²⁾	20.00	58.0	5.0	410, (with IMS)		
10 ²⁾	10.00	29.0	3.1	2 x 305		
-140-NN-3	1 ¹⁾	300.00	360.0	5.0	370	
	1 (with keyway) ³⁾				500 (with IMS)	
	5 ²⁾	200.00	72.0	5.0	2 x 370	
		12 ²⁾	25.00	30.0	3.2	370
		16 ²⁾	18.75	22.5	2.4	500 (with IMS)
-165-NN-2	1 ¹⁾	367.00	440.0	5.0	400	
	1 (with keyway) ³⁾					200.00
	8 ²⁾	45.00	55.0	4.0	400	
	12 ²⁾	30.00	36.7	3.0		
	16 ²⁾	23.00	27.5	2.0		

1) Valid for versions: 1 or 2 drive journals

2) Valid for versions: Clamping hub or clamping hub with 2nd journal

3) Version with keyway

4) Maximum force that can be transmitted via the teeth meshing with the belt pulley.

5) The maximum permissible tensile load on the belt cross section (belt elasticity limit) is given here for easier comparability. This value represents the load limit in terms of plastic deformation and may not be used to calculate the max. permissible drive torque.

	Constants - mass moment of inertia			Friction torque M_{Rs} (Nm)	Belt pulley diameter d_3 (mm)	Belt type B_t	max. belt drive transmission force $F_{bp}^{4)}$ (N)	Belt elasticity limit $F_{t\ perm}^{5)}$ (N)	Specific spring rate C_{spe} (N)	Max. acceleration a_{max} (m/s ²)
	$k_{J\ fix}$ (kgmm ²)	$k_{J\ var}$ (kgmm)	$k_{J\ m}$ (mm ²)							
	81.8 79.0	0.0151	172	0.49	28.65	20AT3	314	760	0.2 x 10 ⁵	50
	538.00 973.00 544.00 979.00	0.0832	396	1.20 1.80 1.20 1.80	39.79	32AT5	600	2240	0.56 x 10 ⁶	
	2157.00 3,114.00 4,070.00 5,660.00	0.3188	1 065	1.70 2.00 2.00 2.90	65.25	46AT5	1,100	3,200	0.81 x 10 ⁶	
	2,240.00 3,197.00 4153.00 5750.00			1.70 2.00 2.00 2.90						
	7,252.00 10,441.00 12,140.00 19,154.00	1.2326	2,125	3.10 3.90 3.90 5.70	92.31	50AT10	2,160	8,500	2.12 x 10 ⁶	
	7,482.00 10,671.00 12,370.00 19,385.00			3.10 3.90 3.90 5.70						
	32,215.00 37,886.00 58,467.00	3.8113	3 286	9.60 9.60 12.10	114.59	60AT15	5,233	14,770	3.80 x 10 ⁶	
	32,630.00 38,301.00 58,882.00			9.60 9.60 12.10						
	70,428.00 72,485.00	7.0600	4,904	14.50	140.05	75AT20	5,250	18,000	4.2 x 10 ⁶	

Linear modules MKR

Technical data

Deflection

Example

Observe the chapter "Project planning/calculation"!

linear module MKR-080:
 L = 3000 mm F = 1000 N
 From chart -080:
 f = 1.55 mm $f_{max} = 3.75$ mm

The deflection f lies well below the maximum permissible deflection f_{max} , so no additional supports are required.

The graphs apply under the following conditions:

- both ends firmly fixed (200 to 250 mm per side)
- 6 to 8 screws per side
- solid mounting base
- Note L_{max} ; see general technical data

MKR-040-NN-2

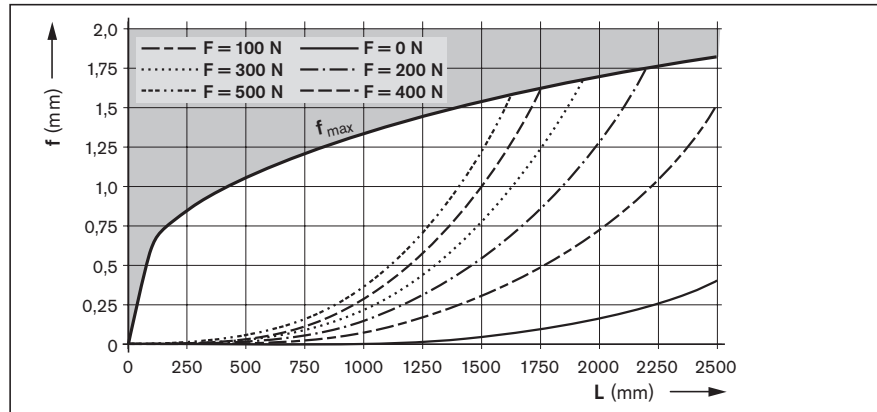

MKR-065-NN-3

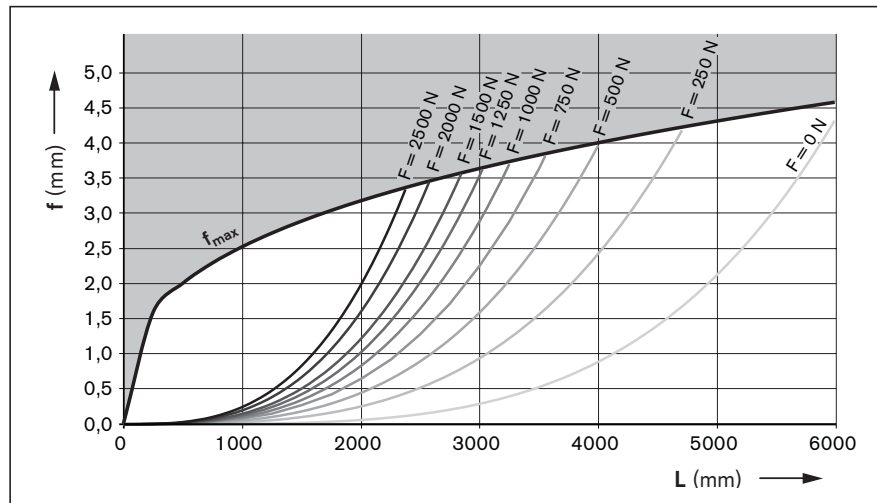

MKR-080-NN-3

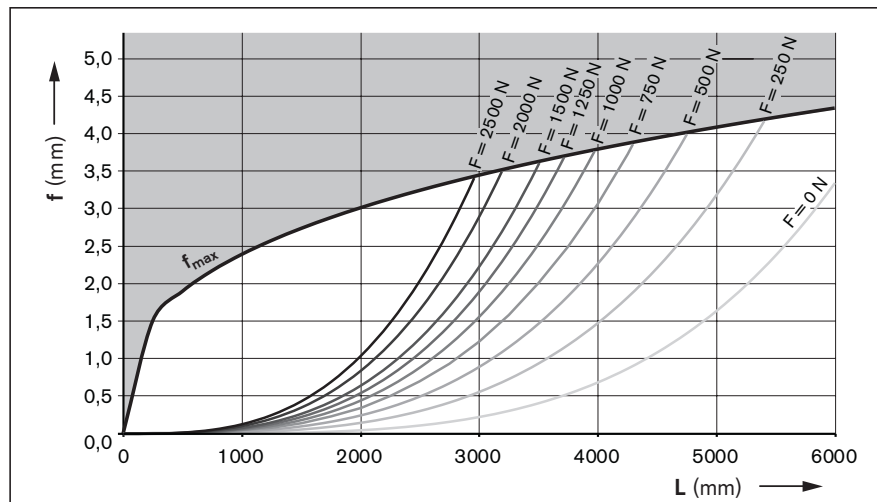

MKR-110-NN-3

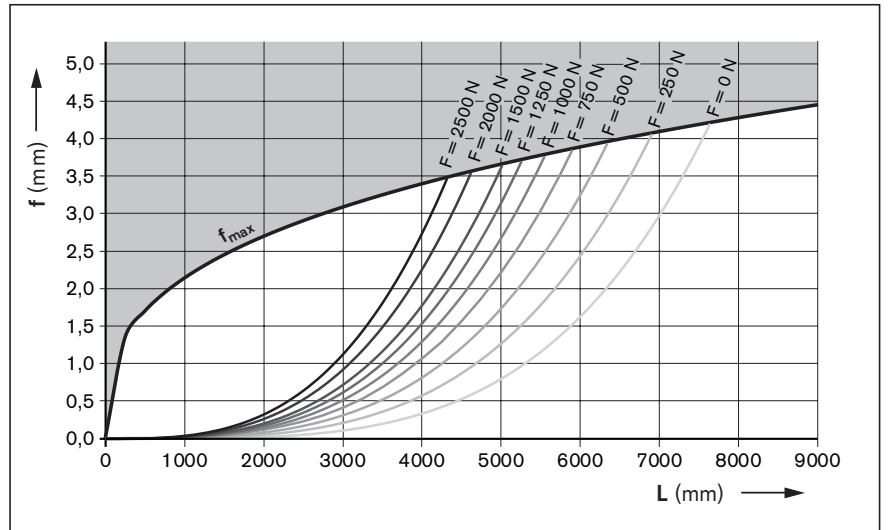

MKR-140-NN-3

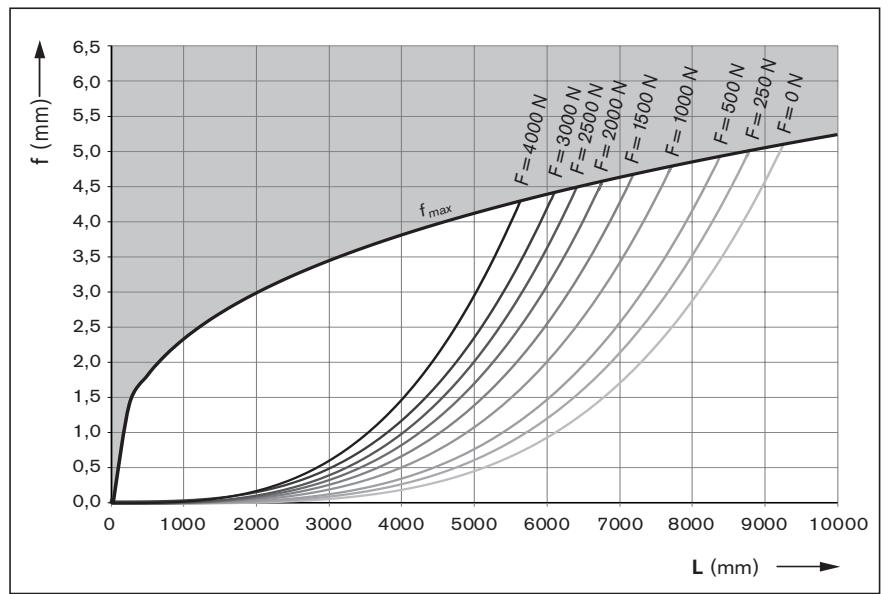

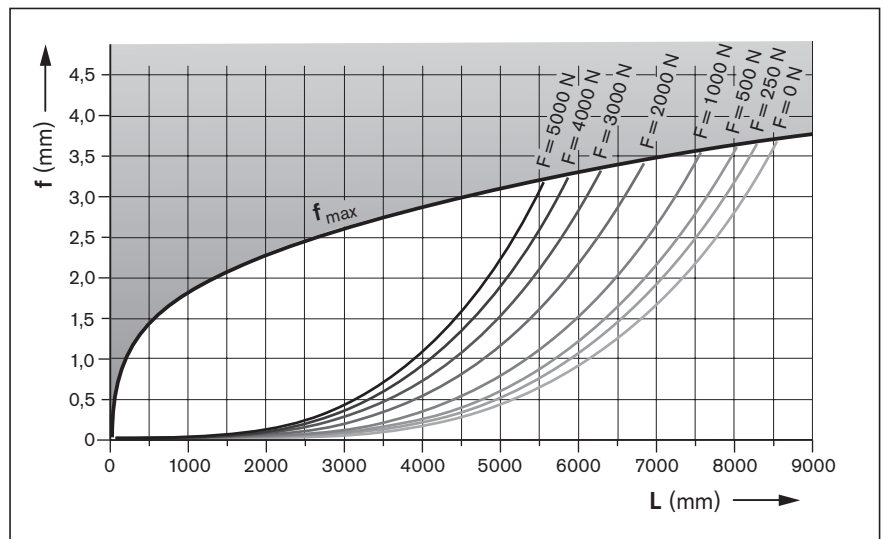

MKR-165-NN-2

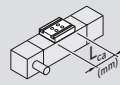
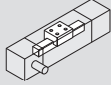
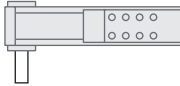
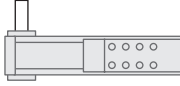
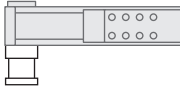

MKR-040-NN-3

Configuration and ordering



s _{max.} ¹⁾ (mm)	Material pairing ²⁾	Lubrication ³⁾ 	Carriage (TT) 			Guideway ⁴⁾ 	Version
			Thread (T)	L (L _{ca} = 135 mm)	Number TT		
s _{max} =	ALST	LSS	T	L	1	001 without	F010 
		LCF					F011 
		LCO				004 with	G010 
		LPG					G011 

1) Travel range s_{max} depends on length L and option selection Length calculation ➡ Chapter "Project planning/calculation"
 2) Material pairing ➡ Chapter "Product description MKR-xxx-NN-3."
 3) Lubrication ➡ see chapter "Additional information".
 4) Centering holes for simple combination with other linear motion systems and connection elements (see dimension drawings).
 Option 004: with centering holes and long hole in the base area of the frame from travel range S_{min} ≥ 155 mm.
 5) Attachment kit also available without motor.
 6) Further switch mounting options ➡ Chapter "Switching system."

Drive journal

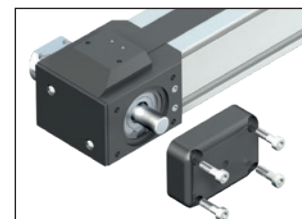
Versions G010 and G011 offer a drive journal, which can be accessed by removing the cover.



Drive		Attachment interface ⁵⁾	Gearing		Motor					Cover		Sensor system ⁶⁾	Automation package	Documentation			
Drive journal	Clamping hub		Gear ratio	Mechanical interface	Motor code	Connection		Holding brake		Motor connector position	Cover	Side sealing	Quantity: 1 - 6	Controller	Cables	Software	
001	-	-	-	-	-	-	-	-	-	-	0 without	0 without	000 without sensor; 130 sensor (PNP NC); 131 sensor (NPN NC) 132 sensor (PNP NO); 133 sensor (NPN NO)	Chapter "Automation package"			001 standard; 002 friction torque; 005 positioning accuracy
002	-	-	-	-	-	-	-	-	-	-	2 with	2 with	000 without sensor; 130 sensor (PNP NC); 131 sensor (NPN NC) 132 sensor (PNP NO); 133 sensor (NPN NO)	Chapter "Automation package"			001 standard; 002 friction torque; 005 positioning accuracy
-	005	011	000	i = 1	-	-	-	2	-	-	-	000	000 without sensor; 130 sensor (PNP NC); 131 sensor (NPN NC) 132 sensor (PNP NO); 133 sensor (NPN NO)	Chapter "Automation package"			001 standard; 002 friction torque; 005 positioning accuracy
			011														
	006		i = 5	MSM031B	MSM031B-0300	-	2				090						
			i = 10	MS2N03-B	MS2N03-B0BYN			Y	N		180						
				MS2N03-D	MS2N03-D0BYN						270						

Version	Motor connector position			
	0 °	90 °	180 °	270 °
G010/G011	000	090 ★	180	270

★ Standard delivery (connector position)

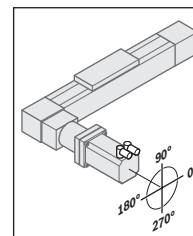

MKR-065-NN-3

Configuration and ordering

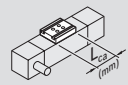
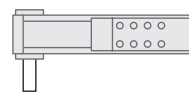
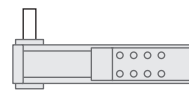
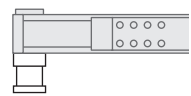
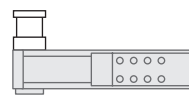
s _{max.} ¹⁾ (mm)	Material pairing ²⁾	Lubrication ³⁾ 	Carriage (TT) 			L _w (mm) (2 TT only)	Guideway ⁴⁾ Frame with or without centering holes	Version	
			T-slot (S) Thread (T)	L (L _{ca} = 190 mm)	Number TT				
s _{max} =	ALST	LSS	S	L	2	L _w =	001 without	F010 	
			T	L					
		LCF	S	L	1	-		004 with	F011 
			LCO	L					
	ALCR	LSS	L	S	L	1	-	011 without	G010 
				T	L				
		LCF	S	L	1	-	014 with		G011 
			LCO	L					
LPG	L	L							

1) Travel range s_{max} depends on length L and option selection Length calculation ➡ Chapter "Project planning/calculation"
 2) Material pairing ➡ Chapter "Product description MKR-xxx-NN-3."
 3) Lubrication ➡ see chapter "Additional information".
 4) Frame with centering holes only possible up to a length of L = 5500 mm.
 5) Attachment kit also available without motor.
 6) Further switch mounting options ➡ Chapter "Switching system."

	Drive			Attachment interface ⁵⁾	Gearing		Motor					Cover		Sensor system ⁶⁾	Automation package			Documentation								
	Without slot	with keyway	Clamping hub		Gear ratio	Mechanical Interface	Motor code	1 cable	2 cables	with	without	Motor connector position	Cover		Side sealing	Quantity: 1 - 6	Controller		Cables	Software						
	001	003	-	-	-	-	-	-	-	-	-	0 without	0 without	000 without sensor; 120 sensor (PNP NC); 121 sensor (NPN NC) 122 sensor (PNP NO); 123 sensor (NPN NO)	Chapter "Automation package"			001 standard; 002 friction torque; 005 positioning accuracy								
	002	004																								
	-	-	006	011	000	i = 1	-	-	-	-	-	2 with	1 with		Chapter "Automation package"											
			011																							
			016 with second journal		011	i = 3 i = 5 i = 10	MS2N03-D	MS2N03-D0BYN	1	-	Y								N	000			Chapter "Automation package"			
							MS2N04	MS2N04-B0BTN												090						
							MS2N04	MS2N04-C0BTN												180						
							MS2N04	MS2N04-D0BQN												270						
					i = 5 i = 10	MSM041	MSM041B-0300	-	2																	
						MSM031C	MSM031C-0300																			

Version	Motor connector position			
	0 °	90 °	180 °	270 °
G010/G011	000	090 ★	180	270



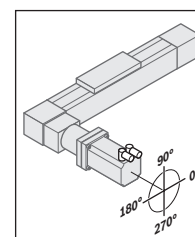

★ Standard delivery (connector position)



Linear modules MKR

MKR-080-NN-3

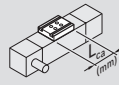
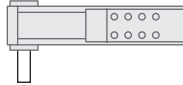
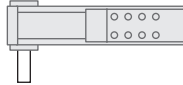
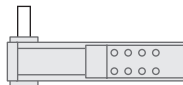
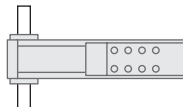
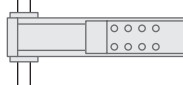
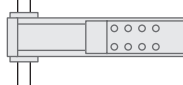
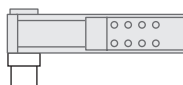
Configuration and ordering

s _{max.} ¹⁾ (mm)	Material pairing ²⁾	Lubrication ³⁾ 	Measuring system IMS- A ⁴⁾ 	Carriage (TT) 			L _w (mm) (2 TT only)	Guideway ⁶⁾ Frame with or without centering holes	Version			
				T-slot (S) Thread (T)	S L _{ca} = 190 mm) L (L _{ca} = 260 mm) ⁵⁾	Number TT						
s _{max} =	ALST	LSS	001 HF	S	L	1	-	104 with	F010 			
			002 DQ	T	L	1	-	104 with	F010 			
			000 without	S	L	2	L _w =	001 without	F011 			
		LCF	S	S	1	-	001 without	F011 				
			LCO	-					T	L	004 with	F020 
			LPG	-					T	L	004 with	F020 
	ALCR	LSS	-	-	S	S	1	-	011 without	G010 		
					LCO	-			T	L	014 with	G011 
					LPG	-			T	L	014 with	G011 

- 1) Travel range s_{max} depends on length L and option selection Length calculation ➡ Chapter "Project planning/calculation"
- 2) Material pairing ➡ Chapter "Product description MKR-xxx-NN-3."
- 3) Lubrication ➡ see chapter "Additional information".
- 4) Absolute measuring system, L_{max} = 4500 mm (HF = HIPERFACE® interface, DQ = DRIVE-CLiQ interface).
- 5) Carriage with measuring system, L_{ca} = 360 mm
- 6) Frame with centering holes only possible up to a length of L = 5500 mm.
- 7) Attachment kit also available without motor.
- 8) Further switch mounting options ➡ Chapter "Switching system."

	Drive			Attachment interface ⁷⁾	Gearing		Motor					Cover		Sensor system ⁸⁾	Automation package			Documentation
	Without slot	with keyway	Clamping hub		Gear ratio	Mechanical Interface	Motor code	Connection		Holding brake		Motor connector position	Cover		Side sealing	Quantity: 1 - 6	Controller	
	001	003	-	-	-	-	-	-	-	-	-	0 without	0 without	000 without sensor; 120 sensor (PNP NC); 121 sensor (NPN NC) 122 sensor (PNP NO); 123 sensor (NPN NO)	Chapter "Automation package"			001 standard; 002 friction torque; 005 positioning accuracy
	002	004	-	-	-	-	-	-	-	-	-	2 with	1 with					
	-	-	006	011	000 011	i = 1	-	-	-	-	-	-	0 without	000 without sensor; 120 sensor (PNP NC); 121 sensor (NPN NC) 122 sensor (PNP NO); 123 sensor (NPN NO)	Chapter "Automation package"			001 standard; 002 friction torque; 005 positioning accuracy
						MSM041	MSM041B-0300	-	2				000					
						MS2N05	MS2N05-B0BTN						090					
							MS2N05-C0BTN						180					
							MS2N05-D0BRN	1	-	Y	N		270					
		016 with second journal			MS2N06	MS2N06-B1BNN						180						
						MS2N06-D1BNN						270						

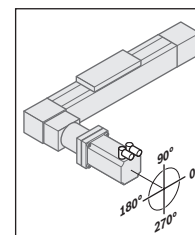

Version	Motor connector position			
	0 °	90 °	180 °	270 °
G010/G011	000	090 ★	180	270

★ Standard delivery (connector position)



MKR-110-NN-3

Configuration and ordering

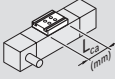
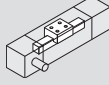
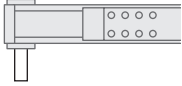
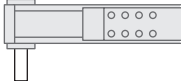
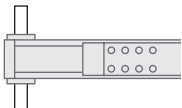
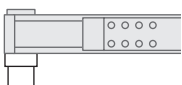
$s_{max.}^1)$ (mm)	Material pairing ²⁾	Lubrication ³⁾ 	Measuring system IMS- A ⁴⁾ 	Carriage (TT) 	L_w (mm)	Guideway ⁶⁾ 	Version		
				T-slot (S) Thread (T) S ($L_{ca} = 210$ mm) L ($L_{ca} = 305$ mm) ⁵⁾ Number TT	(2 TT only)	Frame with or without centering holes			
$s_{max} =$	ALST	LSS	001 HF	S	L	1	-	104 with	F010 
			002 DQ	T	L	1	-	104 with	
			000 without	S	L	2	$L_w =$	001 without	F011 
		LCF	-	S	S	1	-	004 with	F020 
				T	L				
				LPG					
	ALCR	-	LSS	S	1	-	011 without	G010 	
			LCF	S					
			LCO	T					
			LPG	L					

1) Travel range s_{max} depends on length L and option selection Length calculation → Chapter "Project planning/calculation"

2) Material pairing → Chapter "Product description MKR-xxx-NN-3."

3) Lubrication → see chapter "Additional information".

4) Absolute measuring system, $L_{max} = 4500$ mm (HF = HIPERFACE® interface, DQ = DRIVE-CLiQ interface).

5) Carriage with measuring system, $L_{ca} = 410$ mm

6) Frame with centering holes only possible up to a length of L = 5500 mm.

7) Attachment kit also available without motor.

8) Further switch mounting options → Chapter "Switching system."

	Drive		Attachment interface ⁷⁾	Gearing		Motor					Cover		Sensor system ⁸⁾	Automation package			Documentation
	Without slot	with keyway		Gear ratio	Mechanical Interface	Motor code	1 cable	2 cables	with	without	Motor connector position	Cover		Side sealing	Quantity: 1 - 6	Controller	
	001	003	-	-	-	-	-	-	-	-	0 without	0 without	000 without sensor; 120 sensor (PNP NC); 121 sensor (NPN NC) 122 sensor (PNP NO); 123 sensor (NPN NO)	Chapter "Automation package"			001 standard; 002 friction torque; 005 positioning accuracy
	002	004															
	-	-	006	000	i = 1	-	-	-	-	-	2 with	0 without	000 without sensor; 120 sensor (PNP NC); 121 sensor (NPN NC) 122 sensor (PNP NO); 123 sensor (NPN NO)	Chapter "Automation package"			001 standard; 002 friction torque; 005 positioning accuracy
011																	
016 with second journal				011	i = 3 i = 5	MS2N06	MS2N06-B1BNN	1	-	Y	N	000 090 180 270					
							MS2N06-D1BNN										
	-	-	008	000	i = 1	-	-	-	-	-	1 with	1 with	000 without sensor; 120 sensor (PNP NC); 121 sensor (NPN NC) 122 sensor (PNP NO); 123 sensor (NPN NO)	Chapter "Automation package"			001 standard; 002 friction torque; 005 positioning accuracy
012																	
018 with second journal				012	i = 3 i = 5 i = 10	MS2N06	MS2N06-B1BNN	1	-	Y	N	000 090 180 270					
							MS2N06-D1BNN										
	MS2N07-B1BNN																
			MS2N07-C1BRN														
			MS2N07-D1BNN														





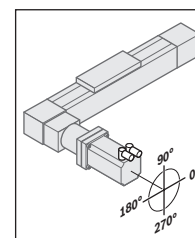

Version	Motor connector position			
	0 °	90 °	180 °	270 °
G010/G011	000	090 ★	180	270

★ Standard delivery (connector position)

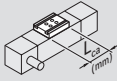
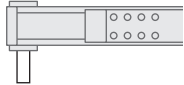
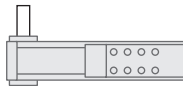

MKR-140-NN-3

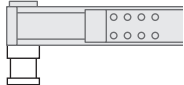
Configuration and ordering

s _{max.} ¹⁾ (mm)	Material pairing ²⁾	Lubrication ³⁾ 	Measuring system IMS- A ⁴⁾ 	Carriage (TT) 			L _w (mm) (2 TT only)	Guideway ⁶⁾ Frame with or without centering holes	Version
				T-slot (S) Thread (T)	L (L _{ca} = 370 mm) ⁵⁾	Number TT			
s _{max} =	ALST	LSS	001 HF	S	L	1	-	104 with	
			002 DQ	T	L	1	-		
			000 without	S	L	2	L _w =	001 without	
		LCF	S	L	1	-			
		LCO	-	T	L	1	-	004 with	
		LPG	-	-	-	-	-	-	-
	ALCR	-	LSS	S	L	1	-	011 without	
			LCF	S	L	1	-		
			LCO	T	L	1	-	014 with	
			LPG	-	-	-	-	-	-

- 1) Travel range s_{max} depends on length L and option selection Length calculation ➡ Chapter "Project planning/calculation"
- 2) Material pairing ➡ Chapter "Product description MKR-xxx-NN-3."
- 3) Lubrication ➡ see chapter "Additional information".
- 4) Absolute measuring system, L_{max} = 4500 mm (HF = HIPERFACE® interface, DQ = DRIVE-CLiQ interface).
- 5) Carriage with measuring system, L_{ca} = 500 mm
- 6) Frame with centering holes only possible up to a length of L = 5500 mm.
- 7) Attachment kit also available without motor.
- 8) Further switch mounting options ➡ Chapter "Switching system."

	Drive		Attachment interface ⁷⁾	Gearing		Motor					Cover		Sensor system ⁸⁾	Automation package			Documentation		
	Without slot	with keyway		Gear ratio	Mechanical interface	Motor code	1 cable	2 cables	with	without	Motor connector position	Cover		Side sealing	Quantity: 1 - 6	Controller		Cables	Software
	001	003	-	-	-	-	-	-	-	-	0 without	0 without	000 without sensor; 120 sensor (PNP NC); 121 sensor (NPN NC) 122 sensor (PNP NO); 123 sensor (NPN NO)	Chapter "Automation package"			001 standard; 002 friction torque; 005 positioning accuracy		
	002	004	-	-	-	-	-	-	-	-	2 with	0 without							
	-	-	008	000 012	i = 1	-	-	-	-	-	1	-	Y	N	000 090 180 270	1 with			
			012	i = 12 i = 16	MS2N06	MS2N06-B1BNN													
						MS2N06-C0BTN													
						MS2N06-D0BRN													
			018 with second journal	i = 5 i = 12 i = 16	MS2N07	MS2N07-B1BNN													
						MS2N07-C1BRN													
						MS2N07-D1BNN													

Version	Motor connector position			
	0 °	90 °	180 °	270 °
G010/G011	000	090 ★	180	270

★ Standard delivery (connector position)

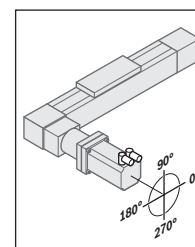

MKR-165-NN-2

Configuration and ordering

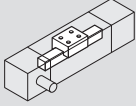
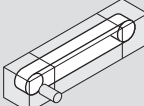
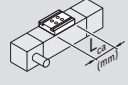
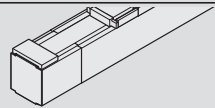
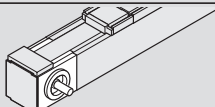
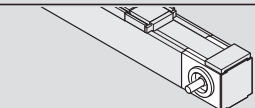
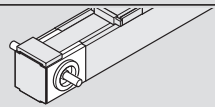
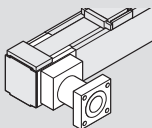
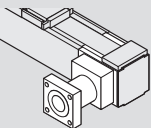

Short product name, length (L) Example: MKR-165-NN-2, (L) mm		Guideway	Drive				Carriage
Version				Gear ratio		with gear reducer	 L _{ca} = 400 mm
			Drive journal	i = 1 ¹⁾	i = 1 ²⁾		
without drive	OA01 	01		50			05
with drive (MA), without gear unit i = 1	MA01 	01	right	01	03	-	
	MA02 	01	left	01	03	-	
	MA03 	01	On both sides	02	04	-	
with gear unit (MG), gear reducer	MG01 	01	Gear reducer right/left	-	-	30	
	MG02 					31 with second journal	

1) Without keyway

2) With keyway

3) Attachment kit also available without motor (when ordering: enter "00" for motor).

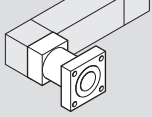
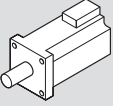
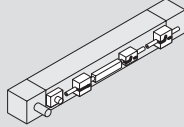
Length calculation ➡ Chapter "General technical instructions"

Motor attachment		Motor						Switch/cable duct/socket-plug	Automation package	Documentation				
														
Gear ratio	Attachment kit ³⁾	Motor code	2 cables Brake		1 cable Brake		Motor connector position	Controller	Cables	Software				
			with-out	with	with-out	with								
-	-	-	-	-	-	-	-	00	Chapter "Automation package"	001 standard; 002 friction torque; 005 positioning accuracy				
-	-	-	-	-	-	-	-	11 13 15						
-	-	-	-	-	-	-	-	20						
-	-	-	-	-	-	-	-	17						
-	-	-	-	-	-	-	-	16						
i = 8	11	MS2N07-B1BNN	-	-	255	256	000 090 180 270	26	Chapter "Automation package"		001 standard; 002 friction torque; 005 positioning accuracy			
		MS2N07-C1BRN	-	-	263	264								
		MS2N07-D1BNN	-	-	269	270								
i = 12	21	MS2N07-B1BNN	-	-	255	256	000 090 180 270	26				Chapter "Automation package"	001 standard; 002 friction torque; 005 positioning accuracy	
		MS2N07-C1BRN	-	-	263	264								
		MS2N07-D1BNN	-	-	269	270								
i = 16	31	MS2N07-B1BNN	-	-	255	256	000 090 180 270	26		Chapter "Automation package"				001 standard; 002 friction torque; 005 positioning accuracy
		MS2N07-C1BRN	-	-	263	264								
		MS2N07-D1BNN	-	-	269	270								

Version	Motor connector position			
	0 °	90 °	180 °	270 °
MG01 / MG02	000	090 ★	180	270

★ Standard delivery (connector position)

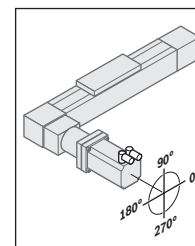

Linear modules MKR

Dimension drawings MKR-040/-065/-080/-110/-140/-NN-3

Frame

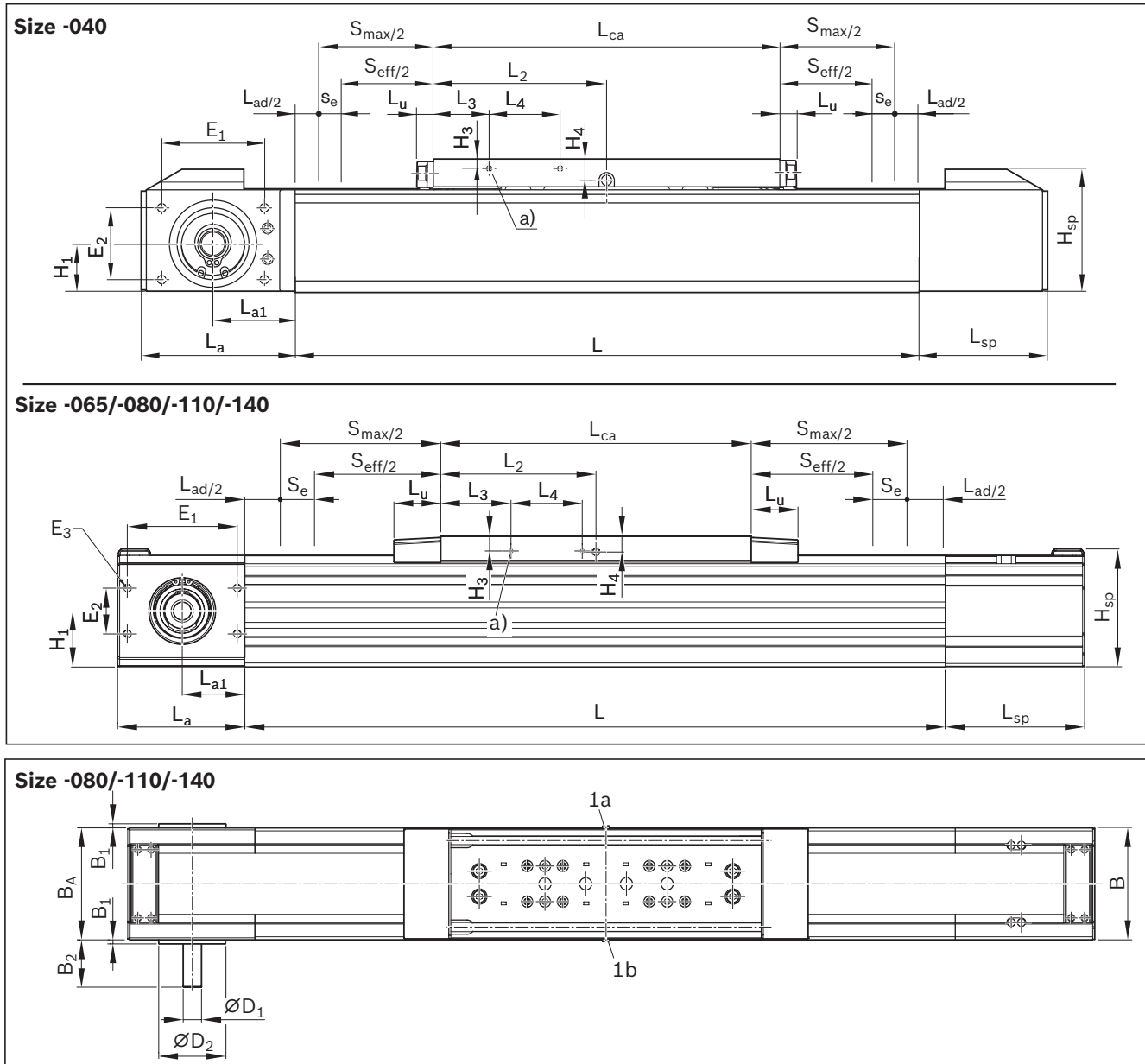

MKR	Dimensions (mm)																			
	B	BA	B1	B2	B3	BS	Ø D1 h7	Ø D2 h7/H7	E1	E2	E3	H	H1	H3	H4	Hsp	Lca	L2	L3	L4
-040-NN-3	40	52	1.6	20.0	12.5	-	10	34	40	28	M4-8 deep	52	19.0	3.7	8.3	48	135	67.5	20.0	27
-065-NN-3	65	80	5	30.0	30.0	-	16	47	60	49	M5-9 deep	85	30.2	13.5	13.5	75	190	95.0	60.0	70
-080-NN-3	80	80	10	53.0	53.0	-	18	66	84	39	M6-10 deep	100	41.0	11.5	12.5	90	190	140.5	47.5	
-080-NN-3																	260	130.0	47.5	
-110-NN-3	110	110	4	46.5	46.5	85	18	66	108	45	M8-18 deep	129	55.0	15.0	16.0	115	210	153.0	50.0	
-110-NN-3																	305	152.5	69.0	
-140-NN-3	140	140	14	72.0	72.0	105	35	112	120	62	M12-20 deep	170	71.5	19.0	19.0	147	370	185.0	70.0	

L_{ad}= additional length → Chapter "Technical data"

See following pages for dimension drawings for carriages and motor attachment.

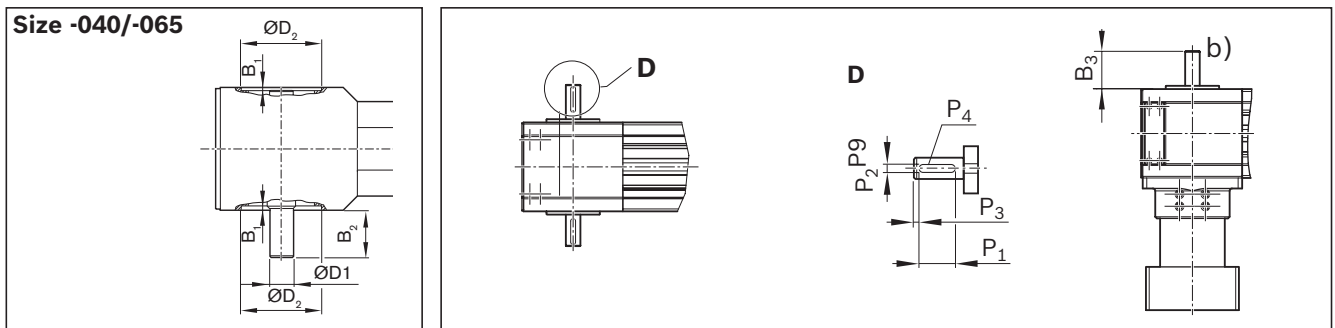
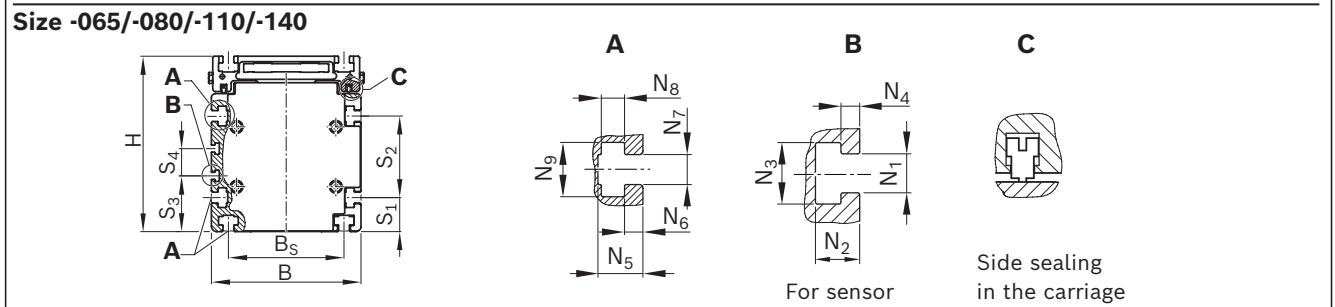
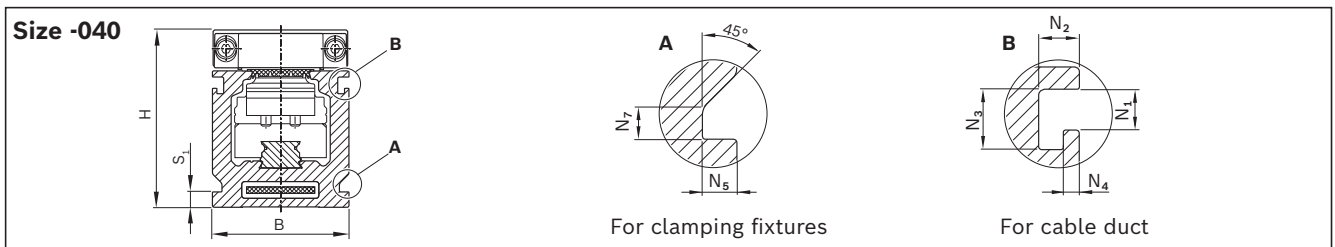
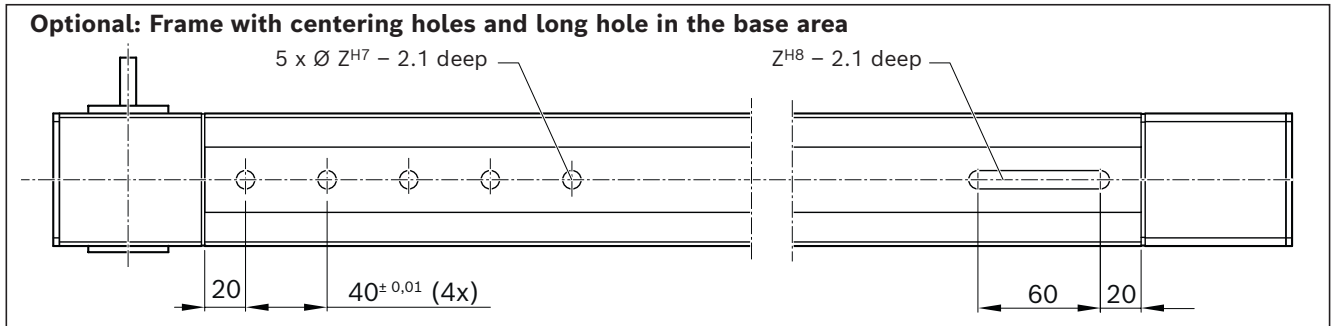

	L _a	L _{a1}	L _u	L _{sp}	Sliding block	N ₁	N ₂	N ₃	N ₄	N ₅	N ₆	N ₇	N ₈	N ₉	P ₁	P ₂ P ₉	P ₃	P ₄ deep	S ₁	S ₂	S ₃	S ₄	Z
	60	32.0	6.5	50	-	3.3	3.3	4.9	1.3	2.8	-	2.5	-	-	-	-	-	-	4.5	-	36.5	-	7
	80	44.0	10	74	DIN557-M5	5.2	5.9	8.2	2.5	8.5	2.5	5.2	5.0	9.0	25	5	3	3.5	18.0	26	30.0	-	9
	102	50.0	50	102	DIN557-M5	5.2	5.9	8.2	2.5	8.5	2.5	5.2	5.0	9.0	32	6	2	3.5	18.0	45	42.5	-	9
	125	61.5	46	137	DIN508-M6	5.2	5.9	8.2	2.5	12.0	4.9	8.0	6.2	14.5	32	6	2	3.5	25.0	60	41.0	20	12
	146	72.0	78	172	DIN508-M8	5.2	5.9	8.2	2.5	15.0	7.0	10.0	7.0	17.0	50	10	5	5.0	37.5	70	80.0	45	16

1a / 1b lube connection for guideway: lubrication on either of the two connections.
 (Funnel-type lube nipple DIN 3405-A M6; Size -040: DIN 3405-A M3)

- a) Fastening thread M4-8 deep (4x) for switching cam
- b) for drive option: Clamping hub with second journal (Ø D₁ x B₃)

MKR-040/-065/-080/
-110/-140/-NN-3

Carriage dimension drawings

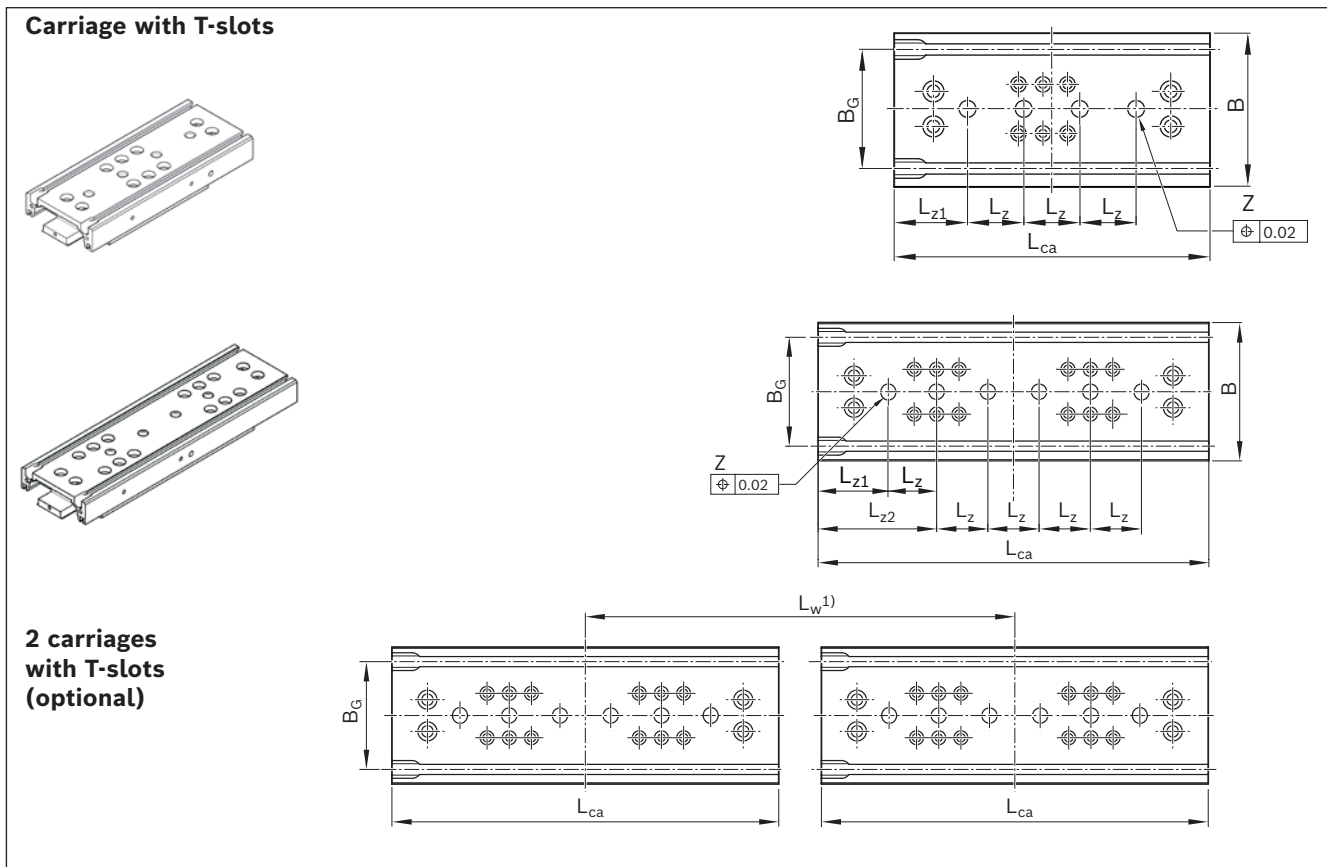
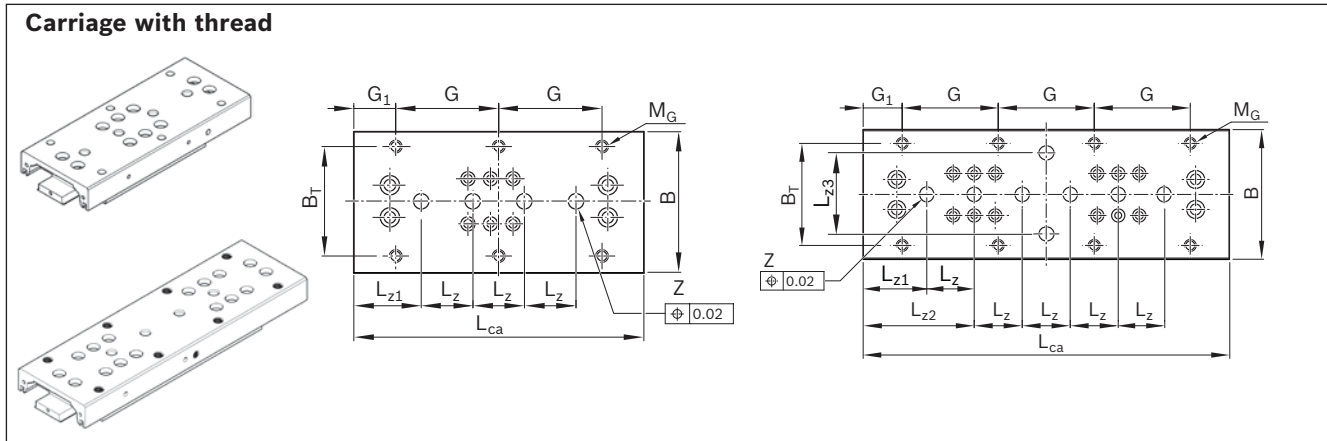

MKR	Dimensions (mm)															
	B	B _G	B _{IMS}	B _T	G	G ₁	H _{IMS}	L _{ca}	L _{ca IMS} ²⁾	L _{w min}	L _{w max}	L _z	L _{z1}	L _{z2}	L _{z3}	
-040-NN-3 (L _{ca} = 135)	39.5	-	-	30	25	30.0	-	135	-	-	-	20	-	37.5	20.0	
-065-NN-3 (L _{ca} = 190)	63.0	46	-	46	50	20.0	-	190	-	234	804	40	-	35.0	-	
-080-NN-3 (L _{ca} = 190)	78.0	60	-	60	70	25.0	-	190	-	-	-	40	-	35.0	-	
-080-NN-3 (L _{ca} = 260)	78.0	60	126	60	70	25.0	6.5	260	360	404	1,004	40	-	70.0	-	
-110-NN-3 (L _{ca} = 210)	108.0	85	-	85	80	25.0	-	210	-	-	-	40	-	45.0	-	
-110-NN-3 (L _{ca} = 305)	108.0	85	156	85	80	32.5	8.0	305	410	439	1,209	40	-	92.5	-	
-140-NN-3 (L _{ca} = 370)	138.0	105	186	105	105	27.5	12.0	370	500	652	2,032	40	85.0	-	-	

¹⁾ Variable center-to-center distance defined by customer-built attachment.

Centerline-to-centerline distance between minimum and maximum distance in 5 mm steps, selectable in 10 mm steps on MKR-110 and in 15 mm steps on MKR-140.

²⁾ Clamping surface corresponds to L_{ca}

³⁾ Non-usable clamping surface

Carriage with thread and IMS

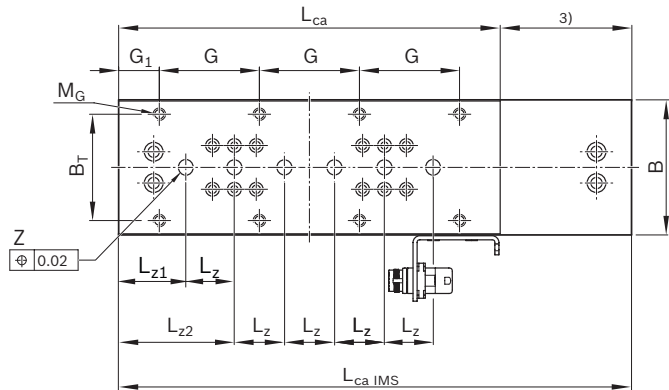
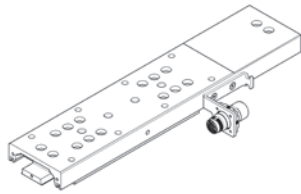

Carriage with T-slots and IMS

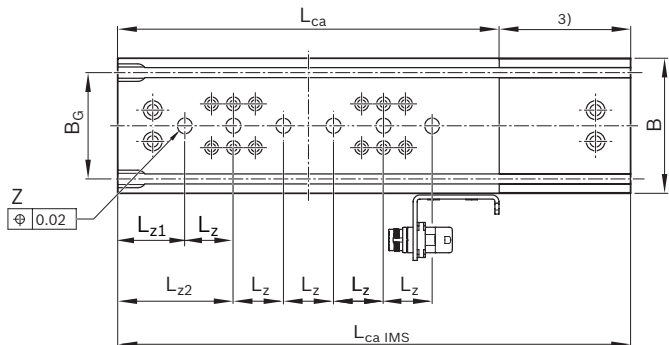
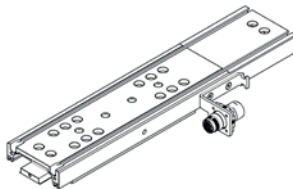

T-slots

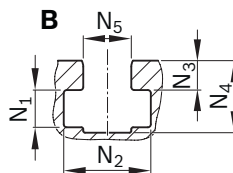
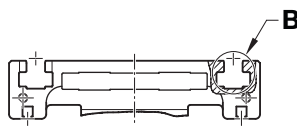

IMS connector

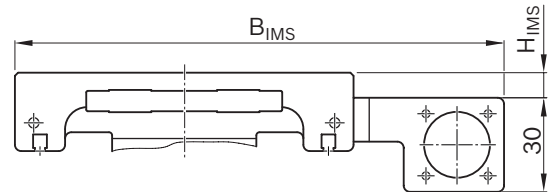

M _G	Sliding block	N ₁	N ₂	N ₃	N ₄	N ₅	ØZ
M4-9 deep (8x)	-	-	-	-	-	-	6 x Ø 7H7-1.6 deep
M6-9 deep (8x)	DIN557-M5	5.0	9.0	2.5	8.5	5.2	4 x Ø 9H7-2.1 deep
M8-10 deep (6x)	DIN557-M5	5.0	9.0	2.5	8.5	5.2	4 x Ø 9H7-2.1 deep
M8-10 deep (8x)	DIN557-M5	5.0	9.0	2.5	8.5	5.2	4 x Ø 9H7-2.1 deep
M10-12 deep (6x)	DIN508-M6	6.2	14.5	4.9	12.0	8.0	4 x Ø 12H7-2.1 deep
M10-12 deep (8x)	DIN508-M6	6.2	14.5	4.9	12.0	8.0	4 x Ø 12H7-2.1 deep
M10-18 deep (8x)	DIN508-M8	7.0	17.0	7.0	14.5	10.0	6 x Ø 16H7-3.1 deep

Linear modules MKR

MKR-040/-065/-080/
-110/-140/-NN-3

Motor attachment
dimension drawings

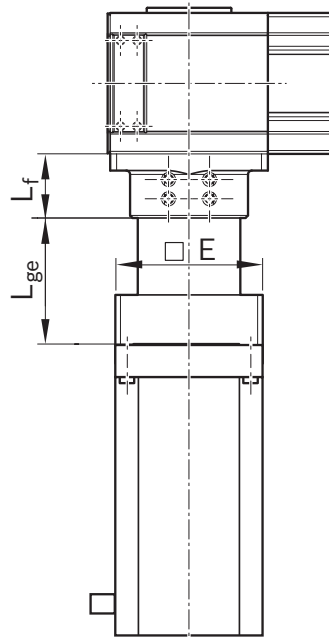

MKR	Gear ratio i	Motor code	Dimensions (mm)		
			□ E	L _f	L _{ge}
-040-NN-3	5 / 10	MS2N03-B0BYN	60	31.0	67.5
		MS2N03-D0BYN			
		MSM031B-0300			
-065-NN-3	3/5/10	MS2N03-D0BYN	60	36.5	71.0
		MS2N04-B0BTN	80		78.0
		MS2N04-C0BTN			
		MS2N04-D0BQN			
		MSM031C-0300	60		78.5
		MSM041B-0300	80		85.5
-080-NN-3	3/5/10	MSM041B-0300	80	54.0	98.5
		MS2N05-B0BTN	100		101.5
		MS2N05-C0BTN			
		MS2N05-D0BRN			
		MS2N06-B1BNN	115		113.5
		MS2N06-D1BNN			
-110-NN-3	3 / 5	MS2N06-B1BNN	115	50.0	113.5
		MS2N06-D1BNN			
	10	MS2N06-B1BNN	115	62.0	131.5
		MS2N06-D1BNN			
	3/5/10	MS2N07-B1BNN	140	62.0	147.0
		MS2N07-C1BRN			
MS2N07-D1BNN					
-140-NN-3	12 / 16	MS2N06-B1BNN	115	80.0	159.0
		MS2N06-C0BTN			
		MS2N06-D0BRN			
		MS2N06-D1BNN			
	5	MS2N07-B1BNN	140	80.0	147.0
		MS2N07-C1BRN			
		MS2N07-D1BNN			
	12 / 16	MS2N07-B1BNN	140	80.0	174.5
		MS2N07-C1BRN			
		MS2N07-D1BNN			

Further information about motors ➡ Chapter "Motors"

MKR-165-NN-2

Dimension drawings

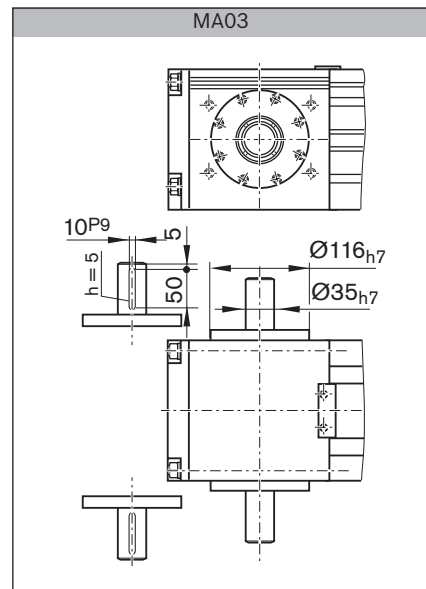
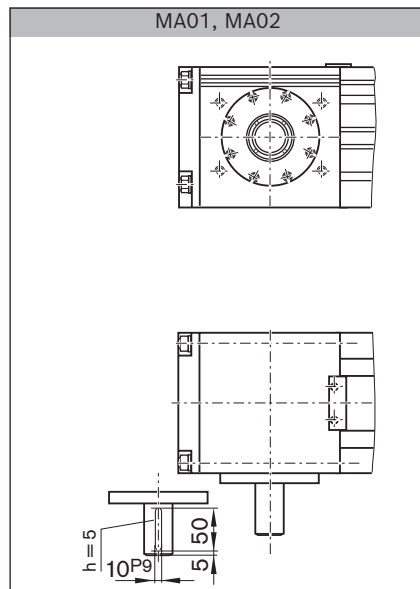
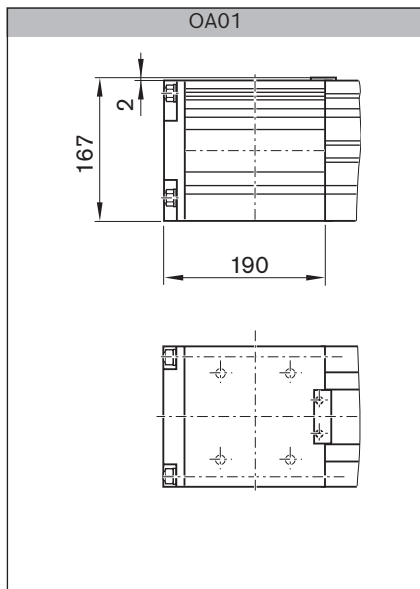
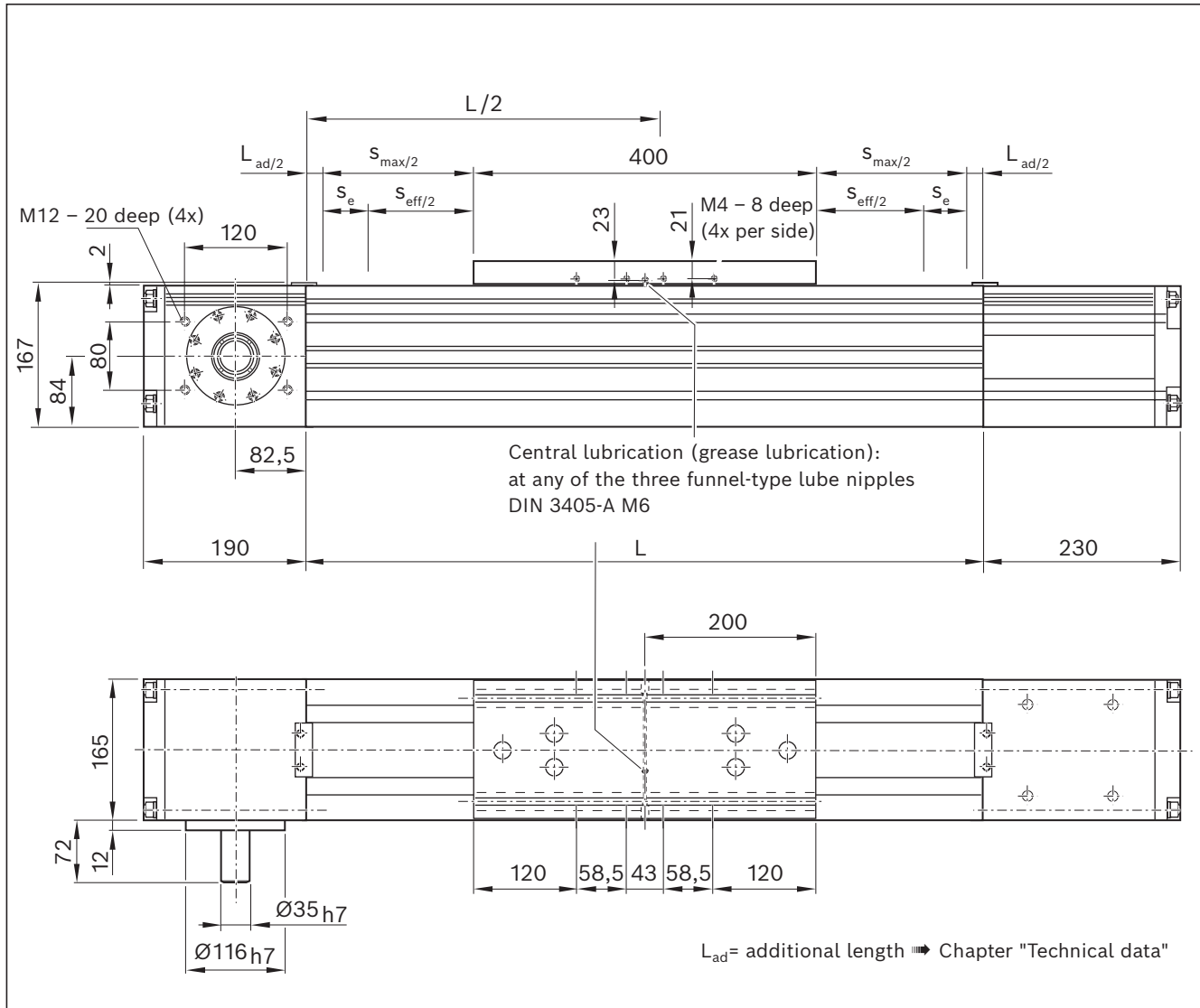

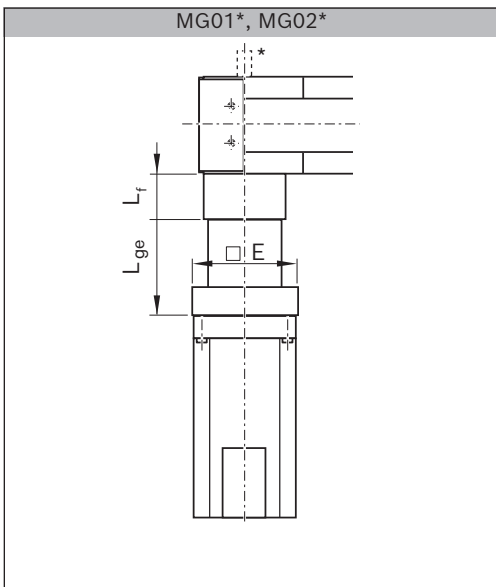
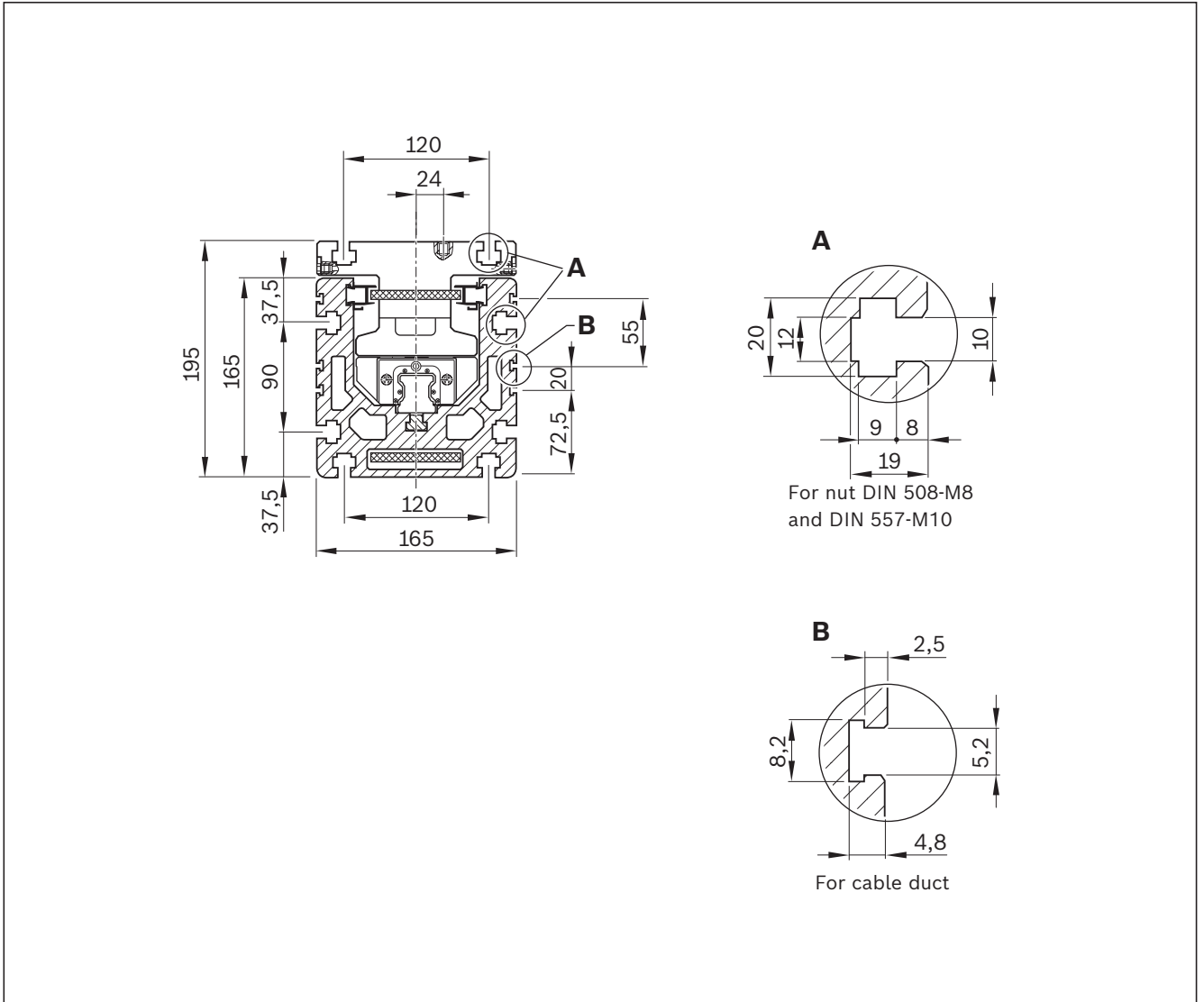

Motor code	Dimensions (mm)				
	□ E	L _f	i = 8	i = 12 ¹⁾	L _{ge} i = 16 ¹⁾
MS2N07-B1BNN	140.0	96.0	168.5	218.0	218.0
MS2N07-C1BRN					
MS2N07-D1BNN					

¹⁾ Two-stage gear

* For drive Option 31: second journal Ø 35 x 72 mm

Further information about motors ➡ Chapter "Motors"

Linear modules MKR-xxx-NN-3 without drive / support axle

Product description MKR-xxx-NN-3 without drive / support axle

Features

- Ready-to-install linear modules in any length up to L_{max}
- Realization of greater lengths of up to 9800 mm
- Extremely compact aluminum profile with integrated Rexroth ball rail system with moderate preload (preload class C1)
- Carriages made of aluminum, in two design versions, with T-slots or threaded holes and with centering holes in each case
- Protection of the guideway components by sealing strip (plastic strip for MKR-040/-065, corrosion-resistant steel strip for MKR-080/-110/-140)

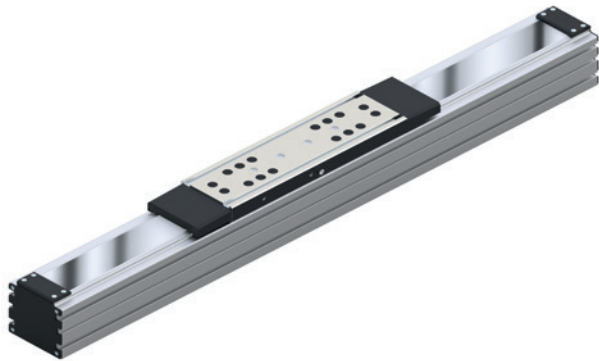

Further highlights

- Available in two material versions, ALST (aluminum/steel version) and ALCR (aluminum/steel hard chrome plated version)
- Centering holes also in the frame profile for simple combination with other linear systems and connection elements
- Standard with integrated solenoid switch for magnetic field sensors

Attachments

- Magnetic field sensors for easy assembly directly on the profile frame
- Switch (proximity or mechanical) cable duct, socket-plug and extension cables in the accessories program

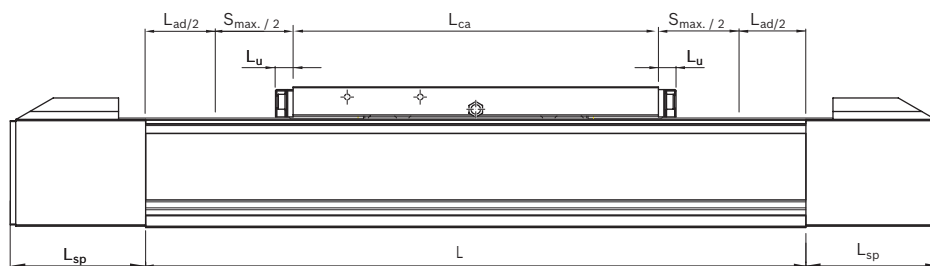
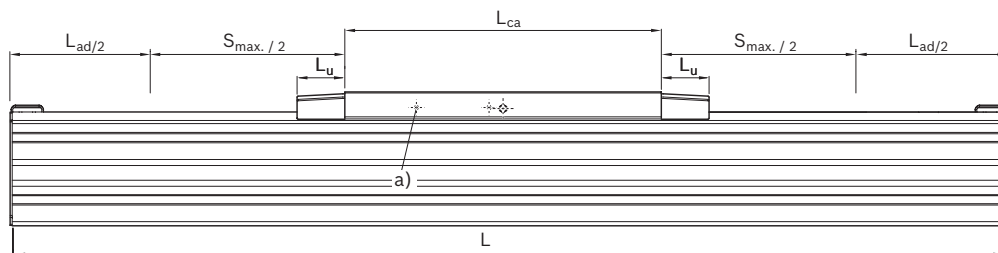





Size -040

MKR	Dimensions (mm)	
	L_{ca}	
-040-NN-3 / TT long (L)	135	
-065-NN-3 / TT long (L)	190	
-080-NN-3 / TT short (S)	190	
-080-NN-3 / TT long (L)	260	
-110-NN-3 / TT short (S)	210	
-110-NN-3 / TT long (L)	305	
-140-NN-3 / TT long (L)	370	



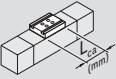

For further information, please refer to the chapter "Linear modules MKR," dimension drawings.

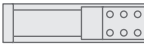
Configuration and ordering



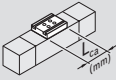

Size -040

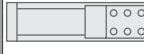
s _{max.} ¹⁾ (mm)	Material pairing ²⁾	Lubrication ³⁾ 	Carriage (TT) 			Guideway ⁴⁾ 		Version	Drive (without)	Cover 			Documentation 	
			Thread (T) Long (L)	Number TT	Frame with or without centering holes	0	without			0	without			
s _{max} =	ALST	LSS	T	L	1	021	without	0000 	000	0	without	0	without	001 Standard
						024*	with			2	with			

Size -065

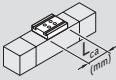
s _{max.} ¹⁾ (mm)	Material pairing ²⁾	Lubrication ³⁾ 	Carriage (TT) 			Guideway ⁴⁾ 		Version	Drive (without)	Cover 			Documentation 	
			T-slot (S) Thread (T) Long (L)	Number TT	Frame with or without centering holes	0	without			0	without			
s _{max} =	ALST	LSS	S	L	1	021	without	0000 	000	0	without	0	without	001 Standard
						024	with			0	without			
	ALCR		T	031	without	2	with			1	with			
				034	with									

Size -80 /-110 /-140

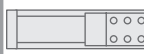
s _{max.} ¹⁾ (mm)	Material pairing ²⁾	Lubrication ³⁾ 	Carriage (TT) 			Guideway ⁶⁾ 		Version	Drive (without)	Cover 			Documentation 	
			T-slot (S) Thread (T) Short (S) Long (L)	Number TT	Frame with or without centering holes	0	without			0	without			
s _{max} =	ALST	LSS	S	S	1	021	without	0000 	000	0	without	0	without	001 Standard
						024	with			0	without			
	ALCR		T	L	031	without	2			with	1	with		
					034	with								

Index: see table "Configuration and ordering data" of the corresponding MKR size

Size -040: *Option 024: with centering holes and long hole in the base area of the frame from travel range S_{min} ≥ 155 mm.

Product description MLR-xxx-NN-3

Characteristic features

MLR ...: Linear modules with cam roller guide and toothed belt drive for high-speed applications (up to 10 m/s)

⚠ Linear modules with cam roller guide to be lubricated with oil only!

Features

- Ready-to-install linear modules in any length up to L_{max}
- Realization of greater lengths of up to 10000 mm
- Extremely compact aluminum profile with integrated Rexroth cam roller guide with internal cam rollers (cam rollers, set to zero-clearance via eccentric shafts)
- Aluminum carriages with T-slots and centering holes and central lubrication point (oil lubrication!)
- High-performance toothed belt (AT profile) for high drive torques with simultaneously high rigidity
- Protection of the guide components by toothed belt
- Version available without drive (support axle)

Further highlights

- Centering holes also in the frame profile for simple combination with other linear systems and connection elements
- Standard with integrated solenoid switch for magnetic field sensors
- Extensive accessories range of connection and clamping units and connecting shafts
- Nameplate with parameters for easy commissioning

Attachments

- Planetary gear with various gear ratios
- Attachment kits for motor according to customer specification
- Servo motor
- Magnetic field sensors for easy assembly directly on the profile frame
- Switch (proximity or mechanical) cable duct, socket-plug and extension cables in the accessories program

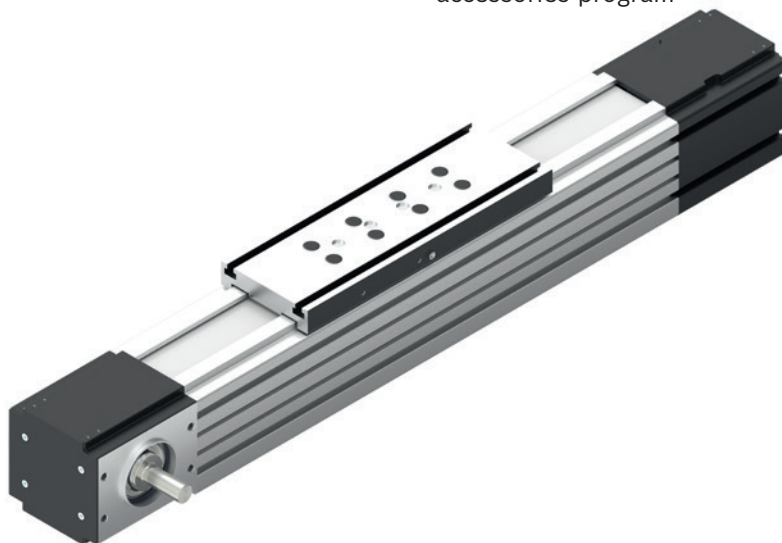

Structural design

Structural design

- 1 Drive side end enclosure
- 2 Toothed belt
- 3 Carriage
- 4 Idler end enclosure
- 5 Frame

Attachments:

- 6 Mechanical switch
- 7 Cable duct
- 8 Magnetic field sensor
- 9 Switching cam
- 10 Proximity switch
- 11 Socket/connector

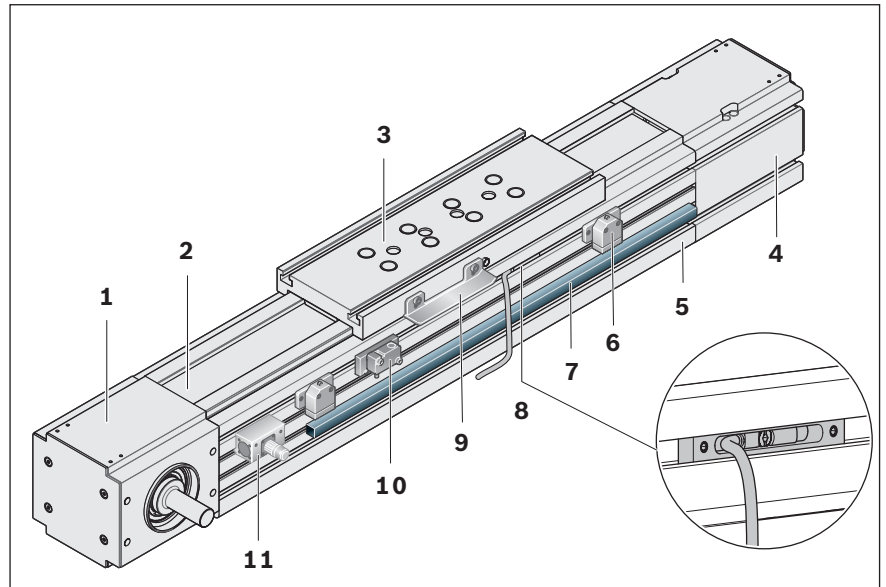

Versions

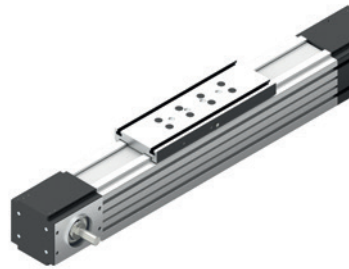

Journals for motor attachment right or left

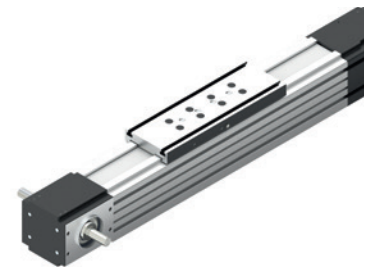

Journals for motor attachment on both sides



With gear reducer (Motor attachment with clamping hub)

Carriage variants

Carriage (TT) with T-slots

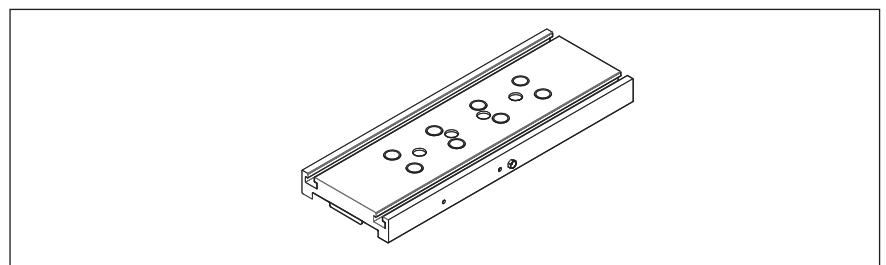

Technical data

General technical data

Observe the chapter "Project planning/calculation"!

MLR	Carriage length L_{ca} (mm)	Dynamic characteristic values				Maximum permissible loads							Moved mass of system m_{ca} (kg)
		Dynamic load capacities		Dynamic load moments		Max. permissible moments			Max. permissible forces				
		C_y (N)	C_z (N)	M_t (Nm)	M_L (Nm)	$M_{x\ max}$ (Nm)	$M_{y\ max}$ (Nm)	$M_{z\ max}$ (Nm)	$F_{y\ max}$ (N)	$F_{z1\ max}$ (N)	$F_{z2\ max}$ (N)		
-080-NN-3	190	17,150	10,050	226	316	35	158	158	2,500	1,500	1,500	1.70	
-110-NN-3	305	31,000	18,200	629	1 121	49	302	302	8,000	4,800	4,800	3.50	

Drive data/gear data

MLR	Gear type ²⁾	Gear ratio i (-)	Max. acceleration torque (at the gear output) $M_{ge}^{3)}$ (Nm)	Base frictional torque M_{Rge} (Nm)
		5	176	0.50
		10	61	0.45
-110-NN-3	PG080	3	136	0.60
		5	176	0.40
	PG120	3	184	1.20
		5	312	0.90
		10	152	0.65

MLR	Gear ratio i (-)	Max. drive torque M_p (Nm)	Feed constant u (mm/rev)	Max. speed v_{max} (m/s)	Constant mass moment of inertia		
					$k_{J\ fix}$ (kg/mm ²)	$k_{J\ var}$ (kg/mm)	$k_{J\ m}$ (mm ²)
-080-NN-3	¹⁴⁾	36.0	205.00	10.0	2,235.0	0.3187	1,064
	1 (with keyway ⁶⁾)	36.0					
	³⁵⁾	12.0	68.33	5.0	2,320.0		
	⁵⁵⁾	7.2	41.00	4.7			
	¹⁰⁵⁾	3.6	20.50	2.4			
-110-NN-3	¹⁴⁾	100.0	290.00	10.0	8,740.0	1.2326	2,125
	1 (with keyway ⁶⁾)	48.0					
	³⁵⁾	33.3	96.67	5.0	8,970.0		
	⁵⁵⁾	20.0	58.00	5.0			
	¹⁰⁵⁾	10.0	29.00	3.1			

¹⁾ Minimum required travel range to guarantee a reliable lubrication distribution. For operating conditions, see chapter "Additional information."
If values are not met, please contact Bosch Rexroth.

²⁾ Planetary gear

³⁾ The limits of the linear motion system must not be exceeded. For more information about calculations, see the chapter "Calculation principles."

⁴⁾ Valid for versions: 1 or 2 drive journals

⁵⁾ Valid for versions: Clamping hub or clamping hub with 2nd journal

⁶⁾ Version with keyway

⁷⁾ Maximum force that can be transmitted via the teeth meshing with the belt pulley.

⁸⁾ The maximum permissible tensile load on the belt cross section (belt elasticity limit) is given here for easier comparability. This value represents the load limit in terms of plastic deformation and may not be used to calculate the max. permissible drive torque.

	Version gear unit	Constant mass calculation		Additional length L_{ad} (mm)	Min. travel range $s_{min}^{1)}$ (mm)	Max. length L_{max} (mm)	Application point of the effective force z_1 (mm)	Planar moments of inertia	
		$k_g \text{ fix}$ (kg)	$k_g \text{ var}$ (kg/mm)					I_y (cm ⁴)	I_z (cm ⁴)
	0000	0.0	0.0075	100	100	10,000	50	158	246
	F010, F011, F020	3.4							
	G010, G011	4.1							
	0000	0.0	0.0134	70	155	10,000	64	499	749
	F010, F011, F020	6.8							
	G010, G011	7.4 (i=3/5); 7.6 (i=10)							

	Max. drive speed $n_{ge}^{3)}$ (rpm)	Motor	Mass moment of inertia J_{ge} (kg/m ²)	Weight m_{ge} (kg)
		MS2N05	0.0001521	2.80
		MSM041B	0.0001521	2.00
	7,000	MS2N06	0.0001290	3.00
		MS2N05	0.0001290	2.80
		MSM041B	0.0001290	2.00
	7,000	MS2N06	0.0001246	3.00
		MS2N05	0.0001246	2.80
		MSM041B	0.0001246	2.00
	7,000	MS2N06	0.0001520	3.00
		MS2N06	0.0001290	3.00
	6,500	MS2N07	0.0004723	7.40
		MS2N07	0.0003995	7.40
		MS2N06	0.0001378	6.20
		MS2N07	0.0003744	7.40

	Friction torque M_{Rs} (Nm)	Belt pulley diameter d_3 (mm)	Belt type B_t	max. belt drive transmission force $F_{bp}^{7)}$ (N)	Belt elasticity limit $F_{t \text{ perm}}^{8)}$ (N)	Specific spring rate c_{spe} (N)	Max. acceleration a_{max} (m/s ²)
		2.0	65.25	46 AT5	1,100	3,200	0.81 x 10 ⁶
	2.9	92.31	50 AT10	2,160	8,500	2.12 x 10 ⁶	

Length calculation ➡ Chapter "Project planning/calculation"
 Short product names ➡ Chapter "Abbreviations"

Linear modules MLR

Technical data

General technical data

Deflection f

Observe the "General technical instructions" chapter

The graphs apply under the following conditions:

- both ends firmly fixed (200 to 250 mm per end)
- 6 to 8 screws per side
- solid mounting base

Example

linear module MLR-080:

$L = 3000 \text{ mm}$ $F = 750 \text{ N}$

From chart MLR-080:

$f = 1.2 \text{ mm}$; $f_{\max} = 3.0 \text{ mm}$



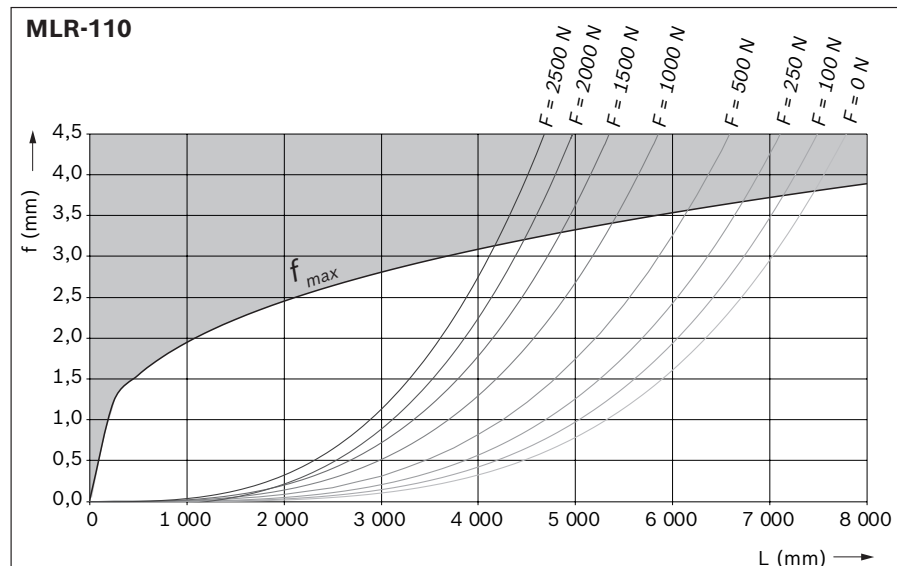
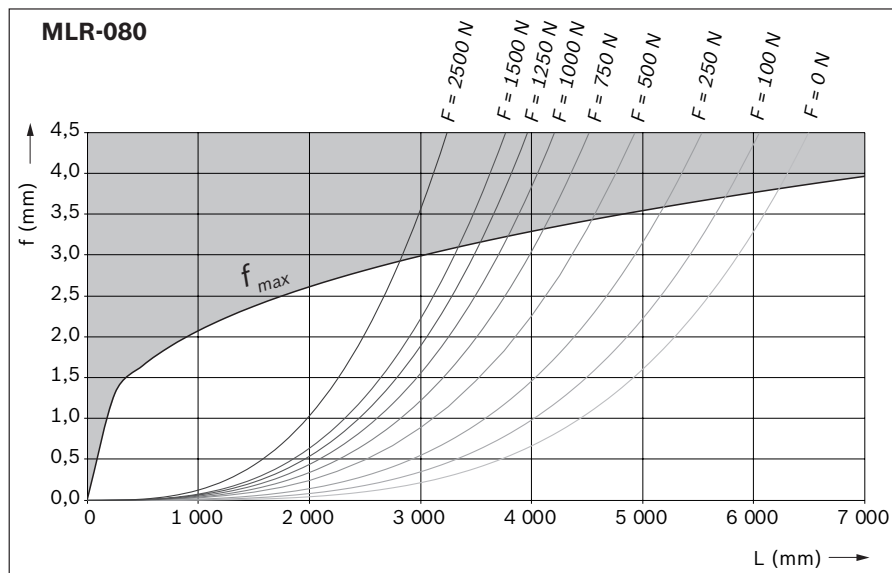

The deflection f lies well below the maximum permissible deflection f_{\max} , so no additional supports are required.

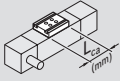
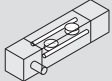
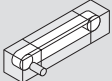

Linear modules MLR

MLR-080-NN-3

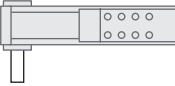
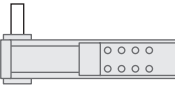
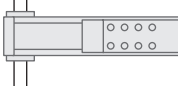
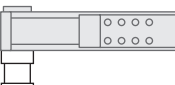
Configuration and ordering



$s_{max.}^{1)}$ (mm)	Carriage (TT)  T-slot $L_{ca} = 190$ (mm)	Guideway ²⁾  Frame with or without centering bores	Version	Drive		
				Without slot	with keyway 	Clamping hub
$s_{max} =$	001	021 without	0000 			
		024 with		000		
		001 without	F010 	001	003	-
			F011 			
			F020 			
		004 with	G010 		006	
			G011 	-	-	016 With second journal

1) Travel range s_{max} depends on length L and option selection Length calculation \Rightarrow Chapter "Project planning/calculation"

2) Frame with centering holes only possible up to a length of L = 5500 mm.

3) Attachment kit with gear unit also available without motor.

4) Further switch mounting options \Rightarrow Chapter "Switching system."

	Mounting interface ³⁾ 	Gearing		Motor					Sensor system ⁴⁾ Quantity: 1 - 6	Automation package			Documentation 
		Gear ratio	Mechanical interface	Motor code	Connection		Holding brake			Motor connector position	Controller	Cables	
	-	-	-	-	1 cable	2 cables	with	without	-	000 without sensor / 140 sensor (PNP NC) 141 sensor (NPN NC) / 142 sensor (PNP NO) 143 Sensor (NPN NO)	-	Chapter "Automation package"	001 standard; 002 friction torque; 005 positioning accuracy
	-	-	-	-	-	-	-	-	-				
	000 011	i = 1	-	-	-	-	-	-	-				
	011	i = 3 i = 5 i = 10	MSM041	MSM041B-0300	-	2			000 090 180 270				
			MS2N05	MS2N05-B0BTN									
				MS2N05-C0BTN									
				MS2N05-D0BRN	1	-	Y	N					
			MS2N06	MS2N06-B1BNN									
				MS2N06-D1BNN									

Version	Motor connector position			
	0 °	90 °	180 °	270 °
G010/G011	000	090 ★	180	270

★ Standard delivery (connector position)

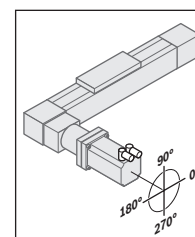

MLR-110-NN-3

Configuration and ordering

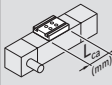
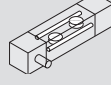
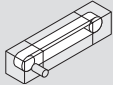
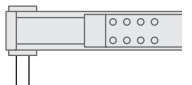
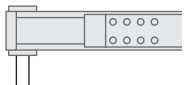
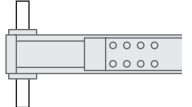
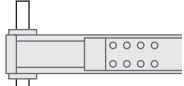
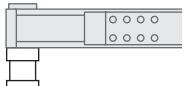
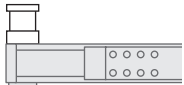

s _{max.} ¹⁾ (mm)	Carriage (TT)  T-slot L _{ca} = 305 (mm)	Guideway ²⁾  Frame with or without centering bores	Version	Drive		
				Without slot	with keyway 	Clamping hub
s _{max} =	001	021 without	0000 	000		
			024 with			
		001 without	F010 	001	003	-
			F011 			
			F020 	002	004	
		004 with	G010 	-	-	006
			G011 			016 with second journal
						008
						018 with second journal

1) Travel range s_{max} depends on length L and option selection. Length calculation  Chapter "Project planning/calculation"

2) Frame with centering holes only possible up to a length of L = 5500 mm.

3) Attachment kit with gear unit also available without motor.

4) Further switch mounting options  Chapter "Switching system."

	Mounting interface ³⁾ 	Gearing		Motor 						Sensor system ⁴⁾ Quantity: 1 - 6	Automation package			Documentation 
		Gear ratio	Mechanical interface	Motor code	Connection		Holding brake		Motor connector position		Controller	Cables	Software	
					1 cable	2 cables	with	without						
	-	-	-	-	-	-	-	-	-					
	-	-	-	-	-	-	-	-	-					
	000 011	i = 1	-	-	-	-	-	-	-					
	011	i = 3 i = 5	MS2N06	MS2N06-B1BNN MS2N06-D1BNN	1	-	Y	N	000 090 180 270					
	000 012	i = 1	-	-	-	-	-	-	-					
	012	i = 10 i = 3 i = 5 i = 10	MS2N06 MS2N07	MS2N06-B1BNN MS2N06-D1BNN MS2N07-B1BNN MS2N07-C1BRN MS2N07-D1BNN	1	-	Y	N	000 090 180 270					

000 without sensor / 144 sensor (PNP NC)
145 sensor (NPN NC) / 146 sensor (PNP NO)
147 Sensor (NPN NO)

001 standard; 002 friction torque; 005 positioning accuracy

Version	Motor connector position			
	0 °	90 °	180 °	270 °
G010/G011	000	090 ★	180	270

★ Standard delivery (connector position)

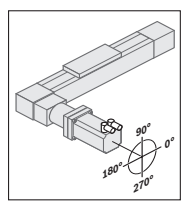

Dimension drawings MLR-080/-110/-NN-3

Frame

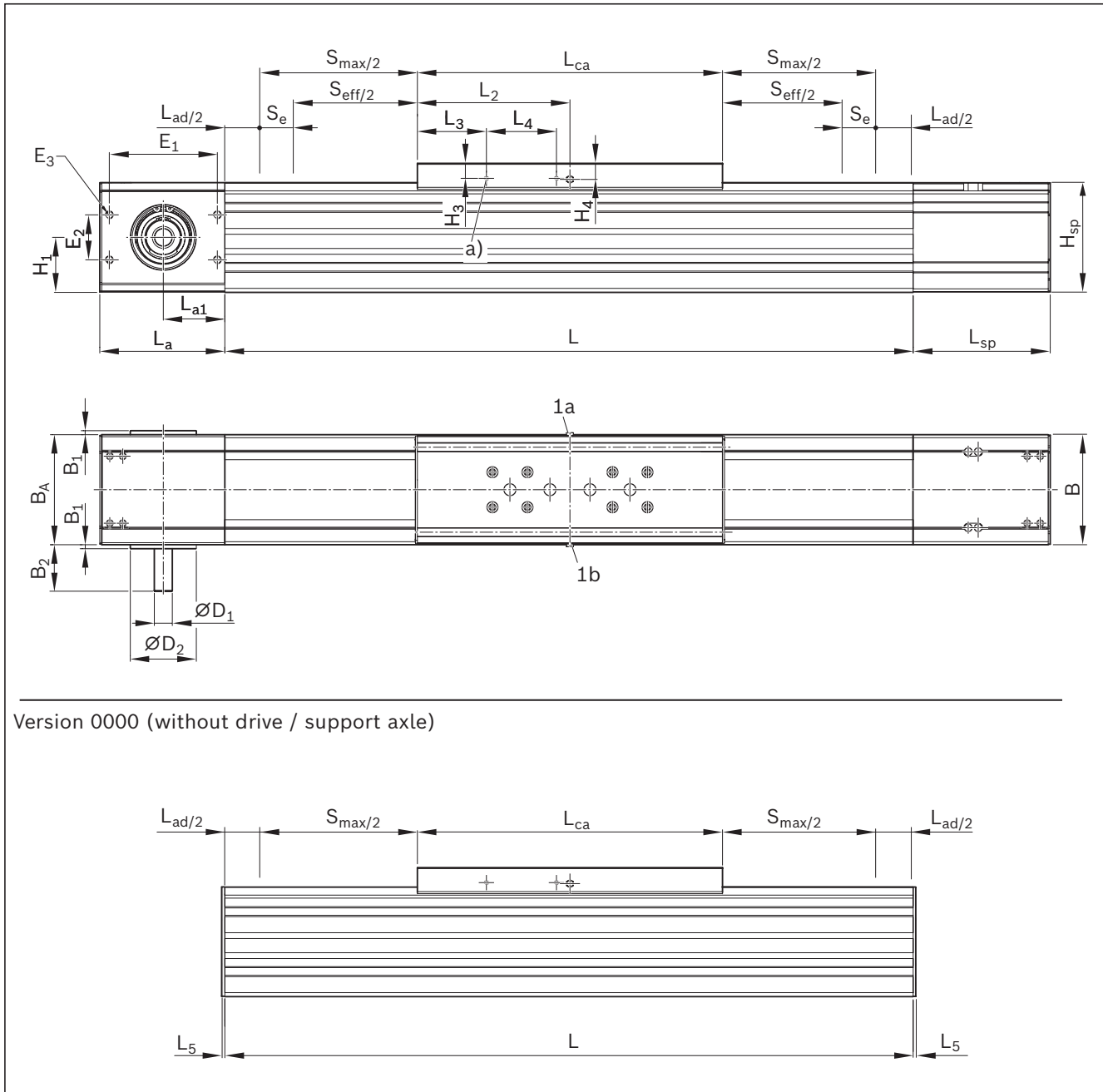

Version 0000 (without drive / support axle)

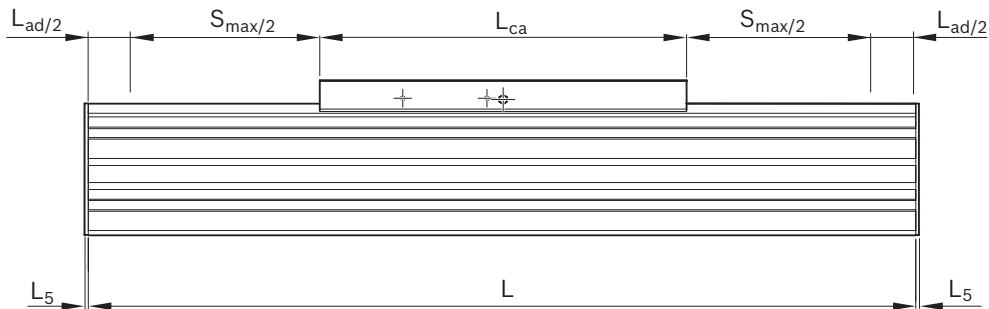

MLR	Dimensions (mm)																				
	B	B _A	B ₁	B ₂	B ₃	B _S	∅ D ₁ h7	∅ D ₂ h7/H7	E ₁	E ₂	E ₃	H	H ₁	H ₃	H ₄	H _{sp}	L _{ca}	L ₂	L ₃	L ₄	L ₅
-080-NN-3	80	80	10	53.0	53.0	-	18	66	84	39	M6-10 deep	100	41.0	11.5	12.5	90	190	145.0	15	70	2
-110-NN-3	110	110	4	46.5	46.5	85	18	66	108	45	M8-18 deep	129	55.0	15.0	15.0	115	305	152.5	69	70	2

L_{ad} = additional length → Chapter "Technical data"

See following pages for dimension drawings for carriages and motor attachment.

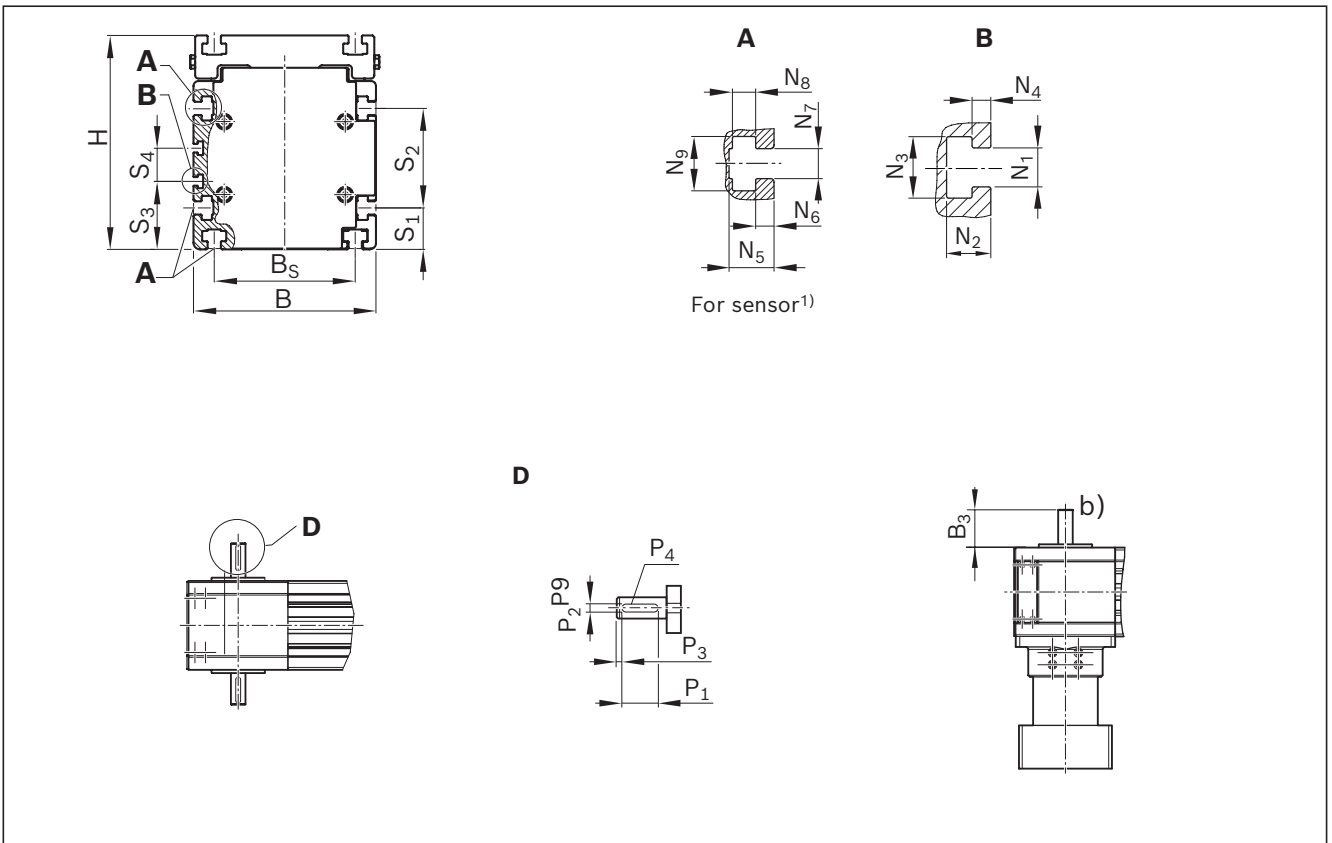
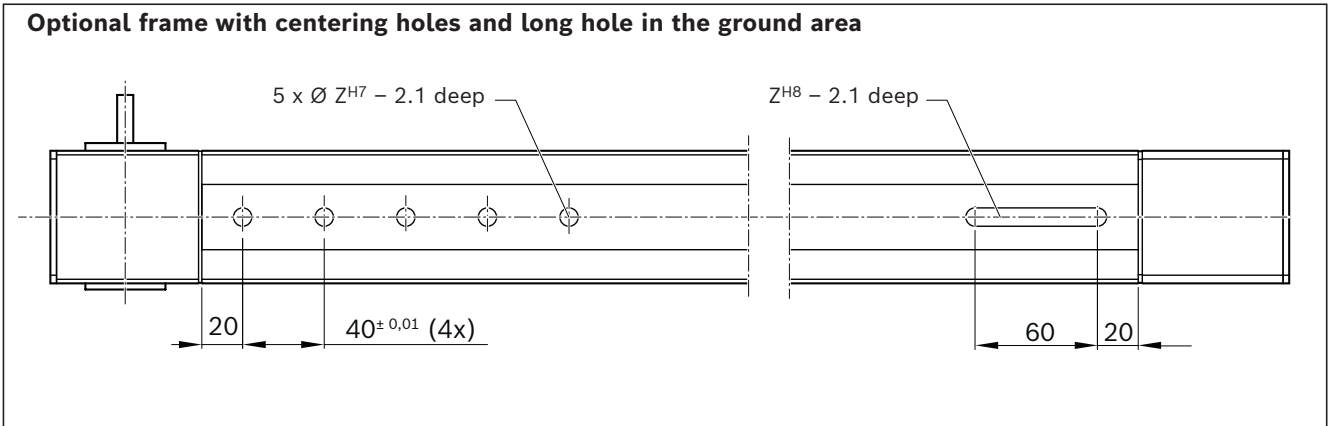

L_a	L_{a1}	L_{sp}	Sliding block	N_1	N_2	N_3	N_4	N_5	N_6	N_7	N_8	N_9	P_1	P_2 P_9	P_3	P_4 deep	S_1	S_2	S_3	S_4	Z
102	50.0	102	DIN557-M5	5.2	5.9	8.2	2.5	8.5	2.5	5.2	5.0	9.0	32	6	2	3.5	18	45	42.5	-	9
125	61.5	137	DIN508-M6	5.2	5.9	8.2	2.5	12.0	4.9	8.0	6.2	14.5	32	6	2	3.5	25	60	41.0	20	12

¹⁾ deviating from MKR; see sensor mounting

1a / 1b lube connection for guideway: lubrication on either of the two connections.
(Funnel-type lube nipple DIN 3405-A M6)

- a) Fastening thread M4-8 deep (4x) for switching cam
- b) for drive option: Clamping hub with second journal ($\varnothing D_1 \times B_3$)

Linear modules MLR

MLR-080/-110/-NN-3

Carriage dimension drawings

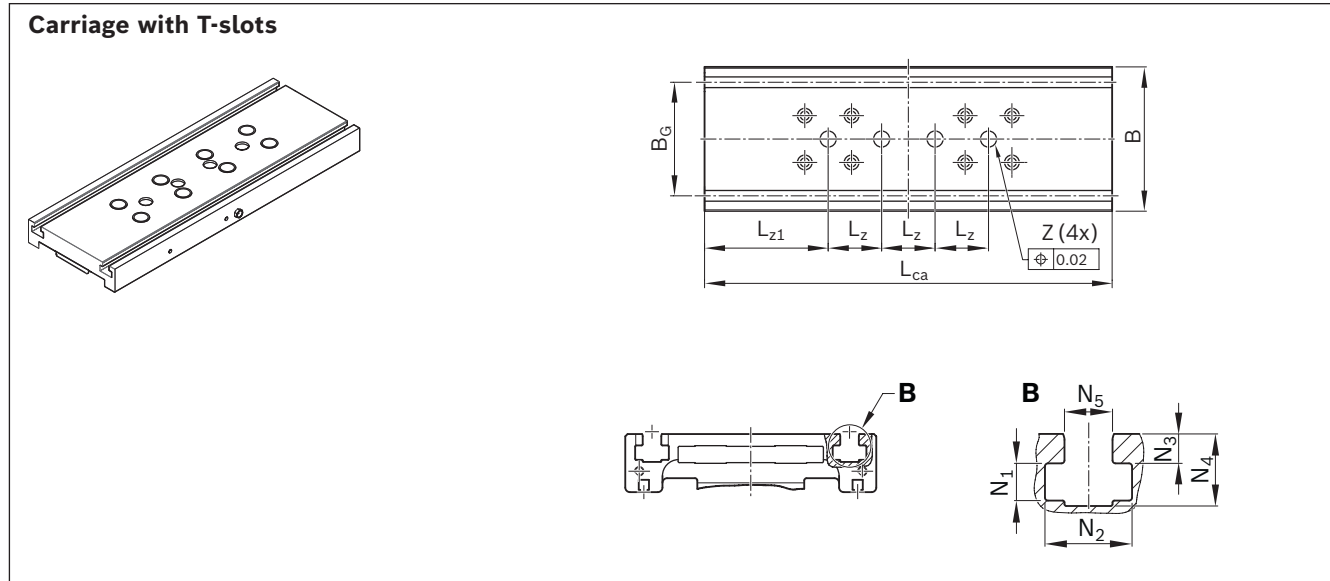

MKR	Dimensions (mm)											ØZ
	B	B _G	L _{ca}	L _z	L _{z1}	Sliding block	N ₁	N ₂	N ₃	N ₄	N ₅	
-080-NN-3	78	60	190	40	35.0	DIN557-M5	5.0	9.0	2.5	8.5	5.2	9H7-2.1 deep
-110-NN-3	108	85	305	40	92.5	DIN508-M6	6.2	14.5	4.9	12.0	8.0	12H7-2.1 deep

Motor attachment dimension drawings

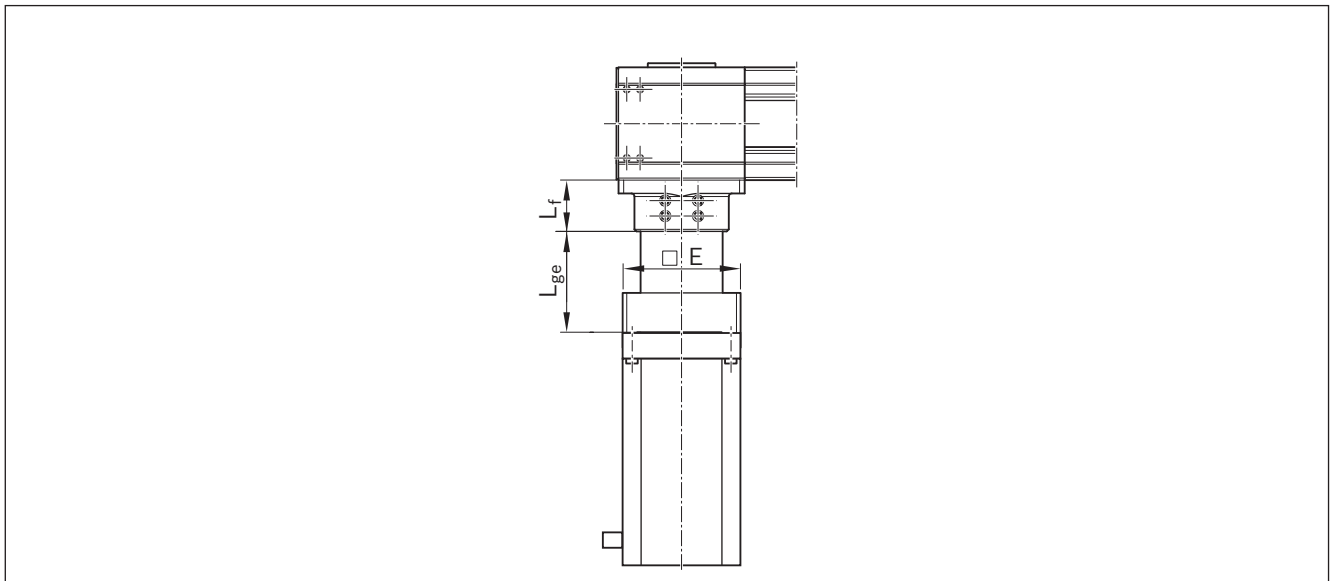

MKR	Gear ratio i	Motor code	Dimensions (mm)		
			□ E	L _f	L _{ge}
-080-NN-3	3/5/10	MSM041B-0300	80	54.0	98.5
		MS2N05-B0BTN	100		101.5
		MS2N05-C0BTN			
		MS2N05-D0BRN			
		MS2N06-B1BNN			
		MS2N06-D1BNN	115		113.5
-110-NN-3	3 / 5	MS2N06-B1BNN	115	50.0	113.5
		MS2N06-D1BNN			
	10	MS2N06-B1BNN	115	50.0	131.5
		MS2N06-D1BNN			
	3/5/10	MS2N07-B1BNN	140	62.0	147.0
		MS2N07-C1BRN			
	MS2N07-D1BNN				

Further information about motors ➡ Chapter "Motors"

Product description MKR-145-NN-3

Features

- Ready-to-install linear modules in any length up to L_{\max}
- Realization of greater lengths of up to 6000 mm
- Rigid aluminum profile frame with Rexroth ball rail system with cover strip
- Ball runner block with moderate preload (Preload class C1)
- Aluminum carriages with T-slots and centering holes
- Economical maintenance thanks to the one-point lubrication feature (grease lubrication or oil lubrication) from both sides via the carriage
- High-performance toothed belt (AT profile) for high drive torques with simultaneously high rigidity

Further highlights

- Centering holes also in the frame profile for simple combination with other linear systems and connection elements
- Standard with integrated solenoid switch for magnetic field sensors
- Extensive accessories range of connection and clamping units and connecting shafts
- Nameplate with parameters for easy commissioning

Attachments

- Planetary gear with various gear ratios
- Attachment kits for motor according to customer specification
- Servo motor
- Magnetic field sensors for easy assembly
- Switch (proximity or mechanical) cable duct, socket-plug and extension cables in the accessories program

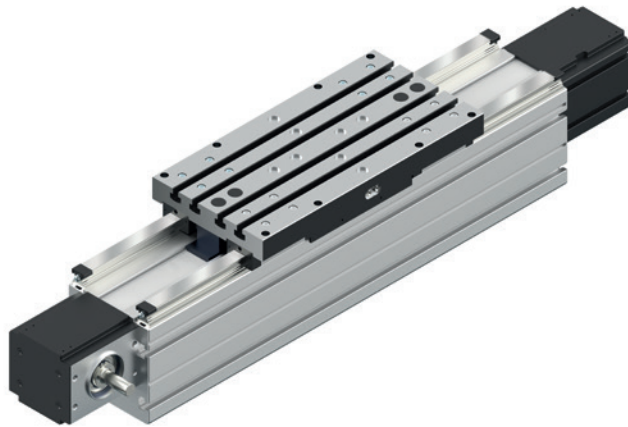

Structural design

Structural design

- 1 Drive side end enclosure
- 2 ball rail systems
- 3 Toothed belt
- 4 Carriage
- 5 Idler end enclosure
- 6 Frame

Attachments:

- 7 Magnetic sensor
- 8 Cable duct
- 9 Switching cam
- 10 Proximity switch
- 11 Mechanical switch
- 12 Socket/connector

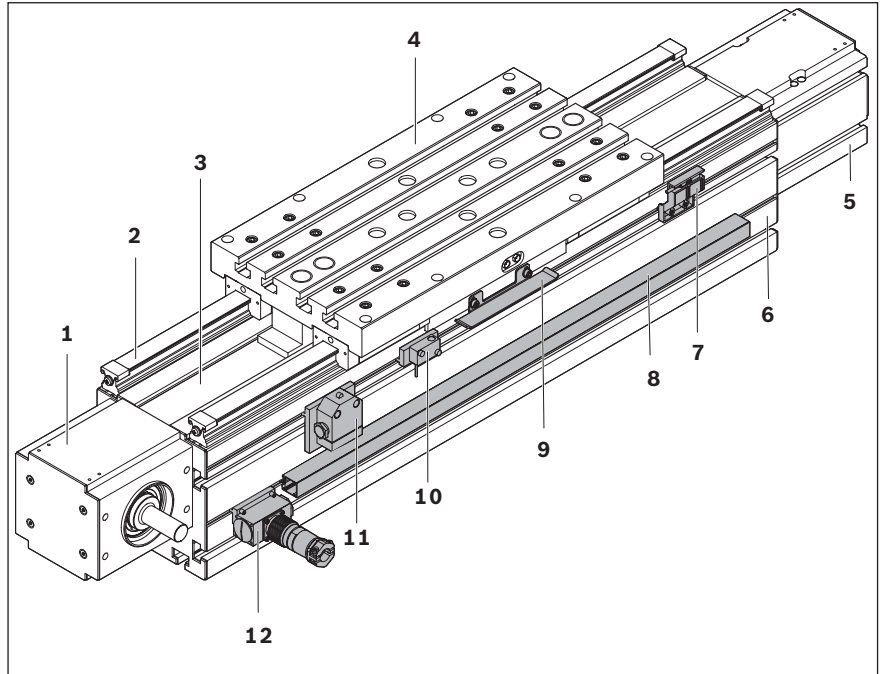

Versions

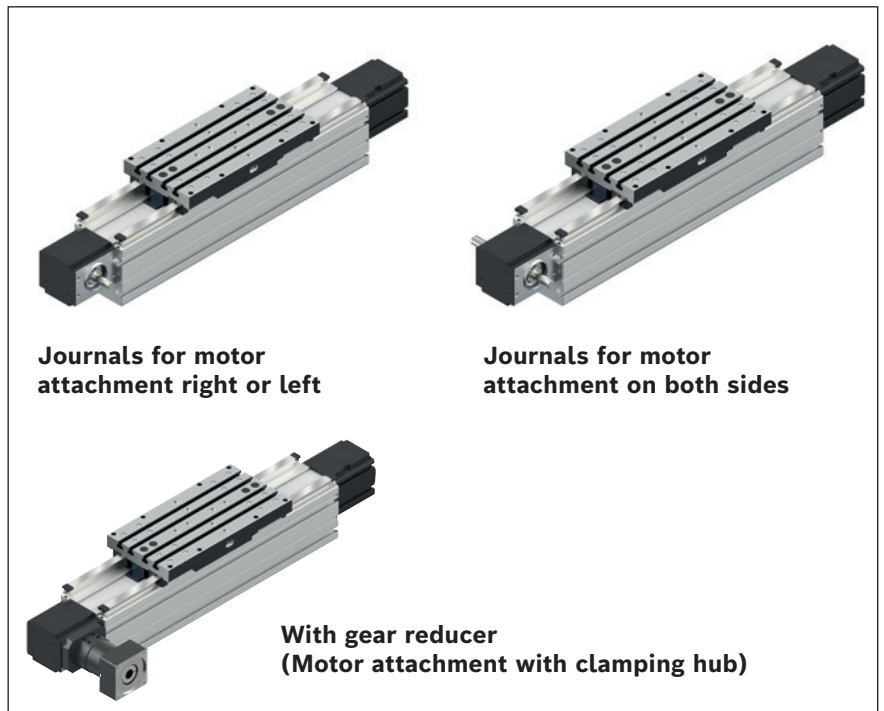

Carriage variants

Carriage (TT) with T-slots

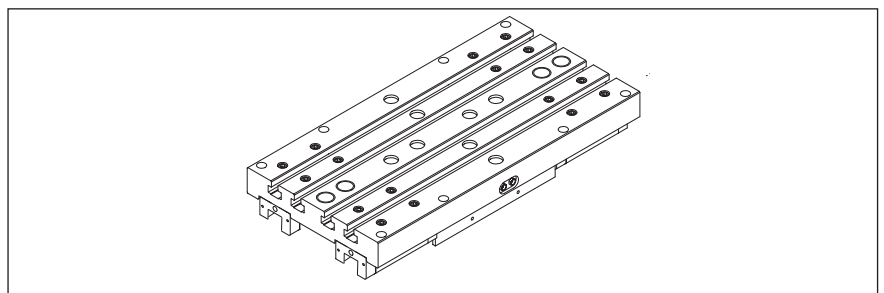

Technical data

General technical data

Read the chapter "Calculation" and the chapter "General technical instructions."

MKR	Carriage length L_{ca} (mm)	Dynamic characteristic values			Maximum permissible loads						Moved mass of system m_{ca} (kg)
		Dynamic load capacities C_{gw} (N)	Dynamic load moments M_t (Nm)		Max. permissible moments $M_{x\ max}$ (Nm)			Max. permissible forces $F_{y\ max}$ (N)			
MKR-145-NN-3	400	121,190	7,030	17,630	2,500	6,300	7,200	49,400	49,400	43,200	9.80

Gear data

Gear type ²⁾	Gear ratio i (-)	Max. acceleration torque (at the gear output) M_{ge} ³⁾ (Nm)	Base frictional torque M_{Rge} (Nm)	Max. drive speed n_{ge} ³⁾ (rpm)	Motor type	Mass moment of inertia J_{ge} (kg/m ²)	Weight m_{ge} (kg)
	5	176	0.40	MS2N06	0.0001290	3.00	
PG120	3	184	1.20	6,500	MS2N07	0.0004723	7.40
	5	312	0.90		MS2N07	0.0003995	7.40
	10	152	0.65		MS2N06	0.0001378	6.20
					MS2N07	0.0003744	7.40

¹⁾ Minimum required travel range to guarantee a reliable lubrication distribution. For operating conditions, see the chapter "Additional information." If values are not met, please contact Bosch Rexroth.

²⁾ Planetary gear

³⁾ The limits of the linear motion system must not be exceeded. For more information about calculations, see the chapter "Calculation principles."

⁴⁾ Valid for versions: 1 or 2 drive journals

⁵⁾ Valid for versions: Clamping hub or clamping hub with 2nd journal

⁶⁾ Version with keyway

⁷⁾ Maximum force that can be transmitted via the teeth meshing with the belt pulley.

⁸⁾ The maximum permissible tensile load on the belt cross section (belt elasticity limit) is given here for easier comparability. This value represents the load limit in terms of plastic deformation and may not be used to calculate the max. permissible drive torque.

Version gear unit	Constant mass calculation		Additional length L_{ad} (mm)	Min. travel range $s_{min}^{1)}$ (mm)	Max. length L_{max} (mm)	Application point of the effective force z_1 (mm)	Planar moments of inertia	
	$k_{g\ fix}$ (kg)	$k_{g\ var}$ (kg/mm)					I_y (cm ⁴)	I_z (cm ⁴)
F010, F011, F020	11.5	0.0357	40	80	6,000	50.5	3,549	3,046
G010, G011	11.8							

Drive data

Gear ratio i (-)	Max. drive torque M_P (Nm)	Feed constant u (mm/rev)	Max. speed v_{max} (m/s)	Constants - mass moment of inertia			Friction torque M_{RS} (Nm)	Belt pulley diameter d_3 (mm)	Belt type B_t	max. belt drive transmission force $F_{bp}^{7)}$ (N)	Belt elasticity limit $F_{t\ perm}^{8)}$ (N)	Specific spring rate c_{spe} (N)	Max. acceleration a_{max} (m/s ²)
				$k_{J\ fix}$ (kg/mm ²)	$k_{J\ var}$ (kg/mm)	$k_{J\ m}$ (mm ²)							
1 ⁴⁾	100.0	290.00	5.0	22,554	1.2326	2,125	6.7	92.31	50 AT10	2,160	8,500	2.12 x 10 ⁶	50
1 with keyway ⁶⁾	48.0												
3 ⁵⁾	33.3												
5 ⁵⁾	20.0												
10 ⁵⁾	10.0												

Length calculation ➡ Chapter "Project planning/calculation"

Short product names ➡ Chapter "Abbreviations"

Deflection

The diagram applies to: both ends firmly fixed (approx. 350 mm per side), 6 to 8 screws per side, fixed mounting base

Example

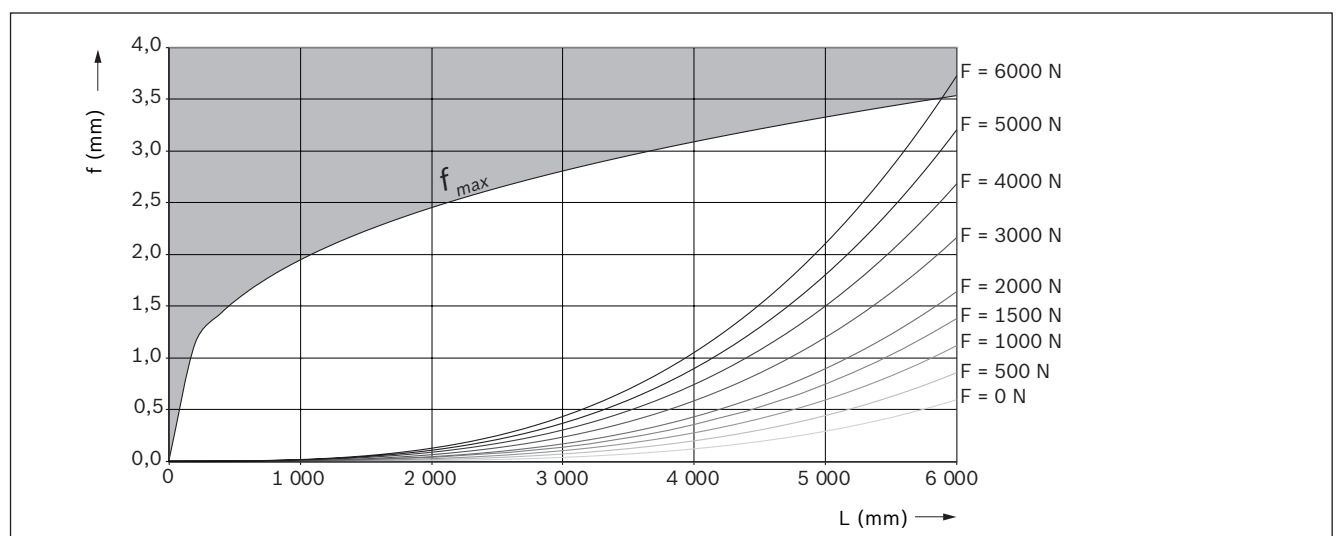

Linear module MKR-145: L = 4000 mm; F = 2000 N; From diagram: f = 0.43 mm; $f_{max} = 3.1$ mm

The deflection f lies well below the maximum permissible deflection f_{max} , so no additional supports are required.

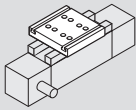
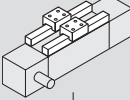
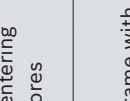

MKR-145-NN-3

Configuration and ordering

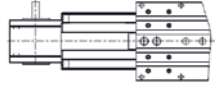
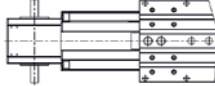
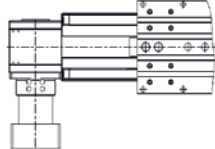
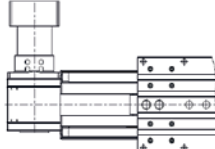
s _{max.} ¹⁾ (mm)	Material pairing ²⁾	Lubrication ³⁾ 	Carriage (TT)  L _{ca} = 400 mm	Guideway ⁴⁾		Version
				Frame without centering bores 	Frame with centering bores 	
s _{max} =	ALST	LSS	011	001	004	F010 
		LCF	021			F011 
		LCO	031			F020 
		LPG	041			G010 
	ALCR	LSS	016	011	014	G011 
		LCF	026			
		LCO	036			
		LPG	046			

1) Travel range s_{max} depends on length L and option selection Length calculation ➡ Chapter "Project planning/calculation"

2) Material pairing ➡ see the chapter "Product description MKR-xxx-NN-3."

3) Lubrication ➡ see chapter "Additional information".

4) Frame with centering holes only possible up to a length of L = 5500 mm.

5) Attachment kit with gear unit also available without motor.

6) Further switch mounting options ➡ Chapter "Switching system."

	Drive			Attachment interface ⁵⁾	Gearing		Motor					Sensor system ⁶⁾	Automation package			Documentation
	Without slot	with keyway	Clamping hub		Gear ratio	Mechanical interface	Motor code	Connection		Holding brake			Motor connector position	Quantity: 1 - 6	Controller	
	001	003	-		-	-	-	-	-	-	-	000 without sensor / 125 sensor (PNP NC); 126 sensor (NPN NC) 127 sensor (PNP NO); 128 sensor (NPN NO)	-	-		
	002	004														
			006	000 011	i = 1	-	-	-	-	-	-					
			016 with second journal	011	i = 3 i = 5	MS2N06	MS2N06-B1BNN MS2N06-D1BNN	1	-	Y	N					000 090 180 270
			008	000 012	i = 1	-	-	-	-	-	-					
			018 with second journal	012	i = 10 i = 3 i = 5 i = 10	MS2N06 MS2N07	MS2N06-B1BNN MS2N06-D1BNN MS2N07-B1BNN MS2N07-C1BRN MS2N07-D1BNN	1	-	Y	N	000 090 180 270				

Version	Motor connector position			
	0 °	90 °	180 °	270 °
G010/G011	000	090 ★	180	270

★ Standard delivery (connector position)

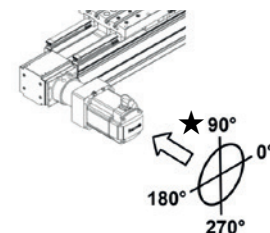

MKR-145-NN-3 dimension drawings

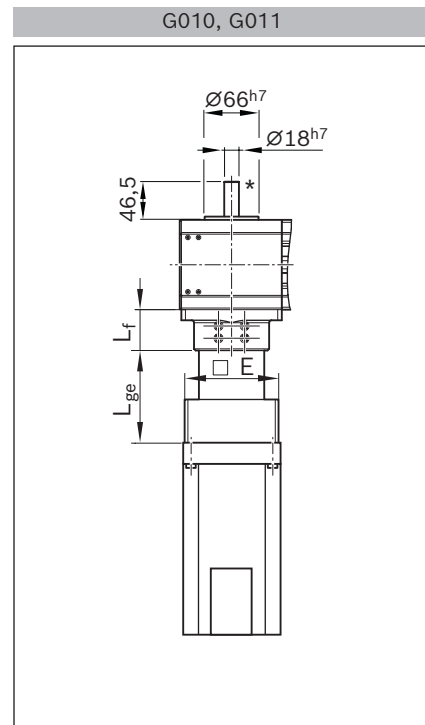
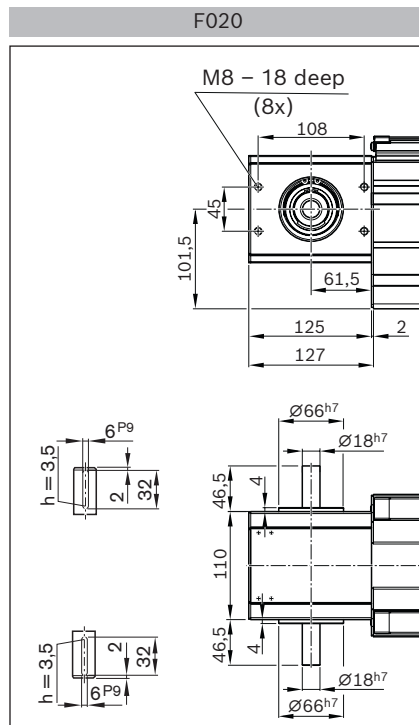
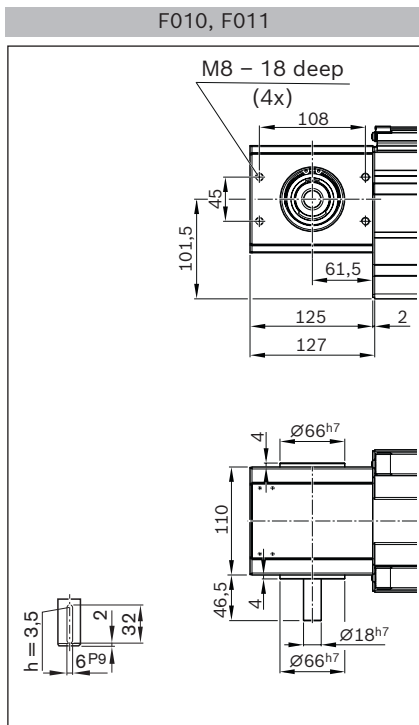
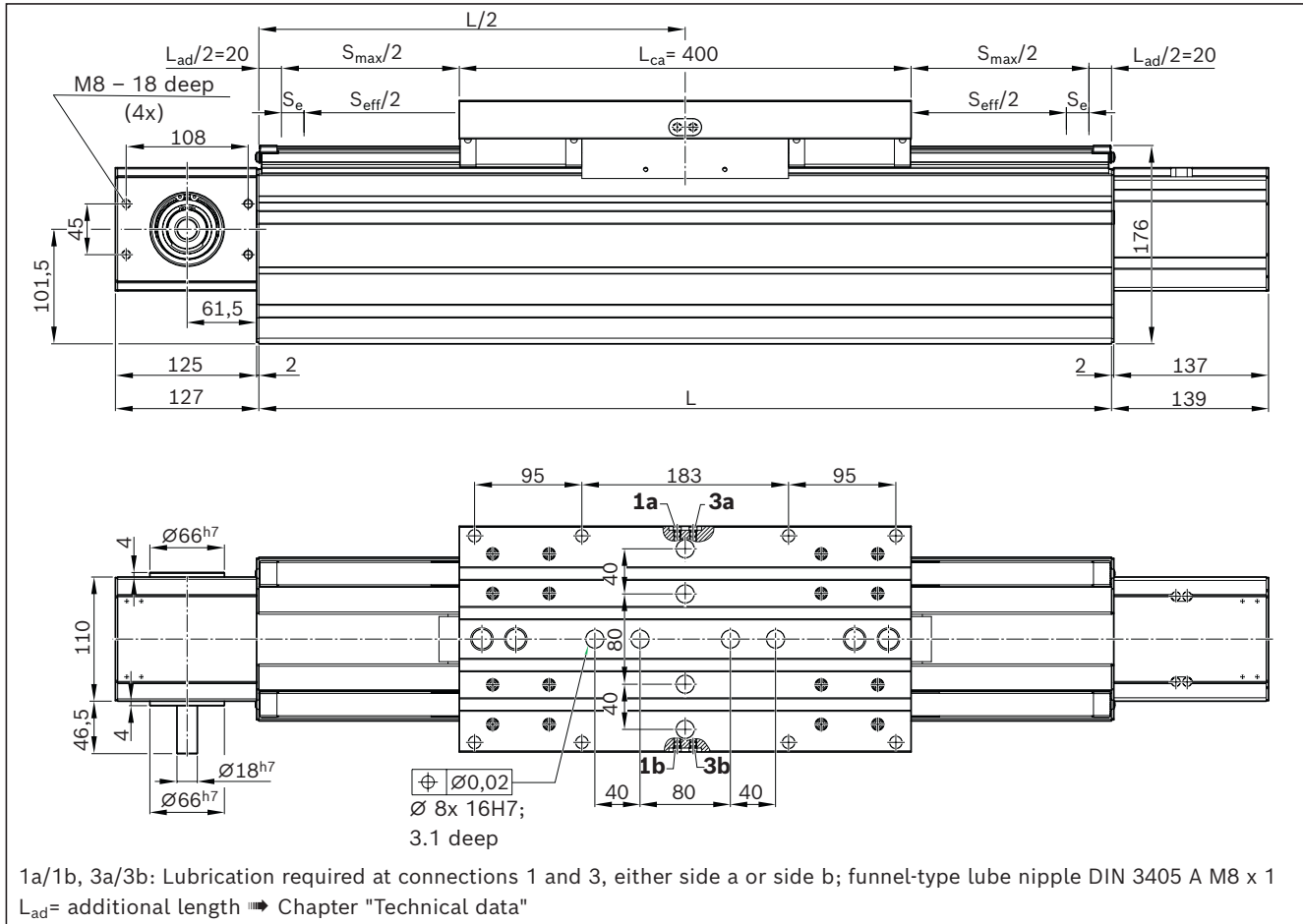

* Version G010, G011: second journal only for drive option 016/018

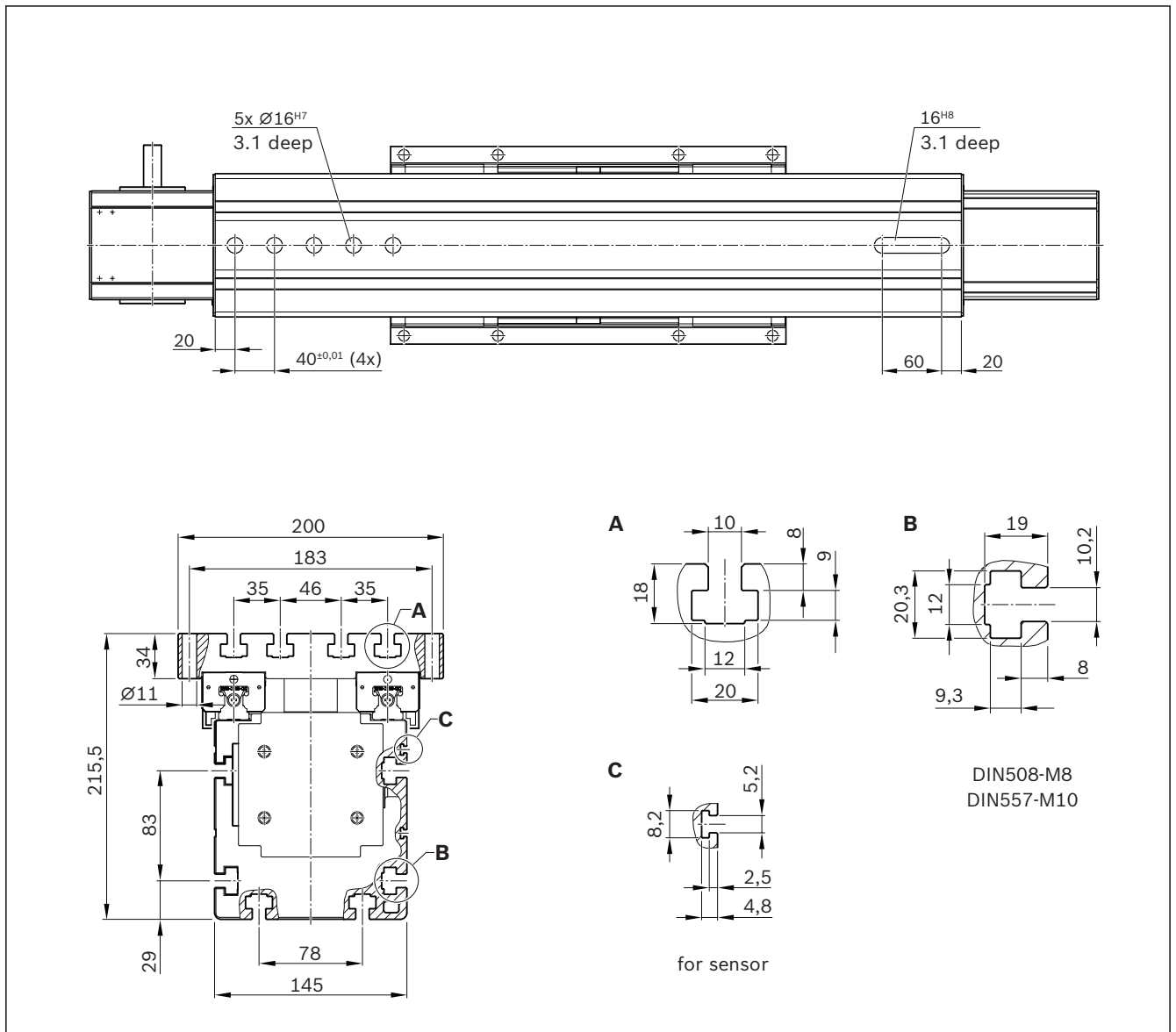

MKR	Gear ratio i	Motor	Motor code	Dimensions (mm)				
				□ E	L_F	L_G		
-145-NN-3	3 / 5	MS2N06	MS2N06-B1BNN	115	50.0	113.5		
			MS2N06-D1BNN					
	10	MS2N06	MS2N06-B1BNN		140	62.0	131.5	
			MS2N06-D1BNN					
	3/5/10	MS2N07	MS2N07-B1BNN			140	62.0	147.0
			MS2N07-C1BRN					
		MS2N07-D1BNN						

Further information about motors ➔ Chapter "Motors"

Attachments and accessories

Fastener

General notes

The linear modules are mounted using various fastening elements:

- Clamping fixtures
- Sliding blocks for size -110 and up
- Square nuts
- Spring nuts
- Screws for T-slots as per DIN 787 (without figure).

Length depends on mounting base.

When mounting linear modules, please note the maximum tightening torques listed in the table.

Size	A (mm)	B (mm)	C (mm)
-040	52.2	65.5	-
-065	81.0	95.0	-
-080	96.0	110.0	-
-110	132.0	150.0	85.0
-140	170.0	196.0	105.0
-145	172.0	198.0	78.0
-165	192.0	218.0	120.0

For additional mounting accessories for the connection system for linear modules see the chapter "Robotic Erector System for linear modules".

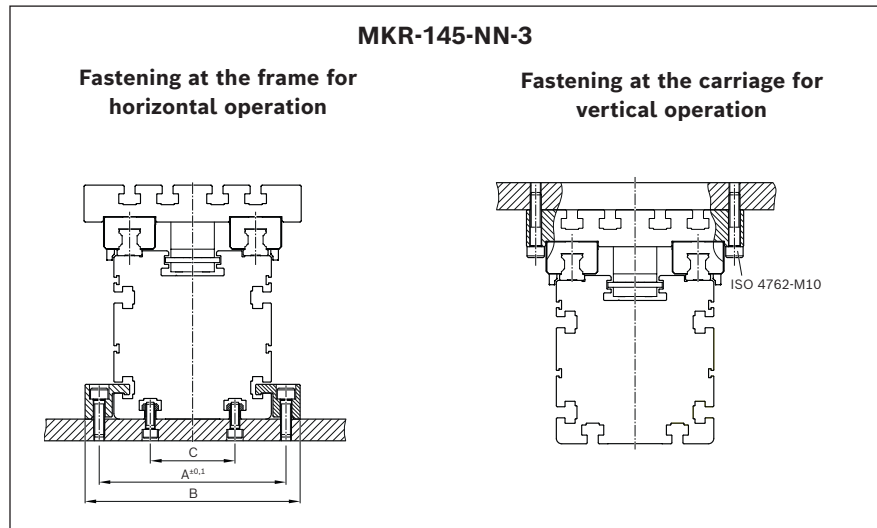
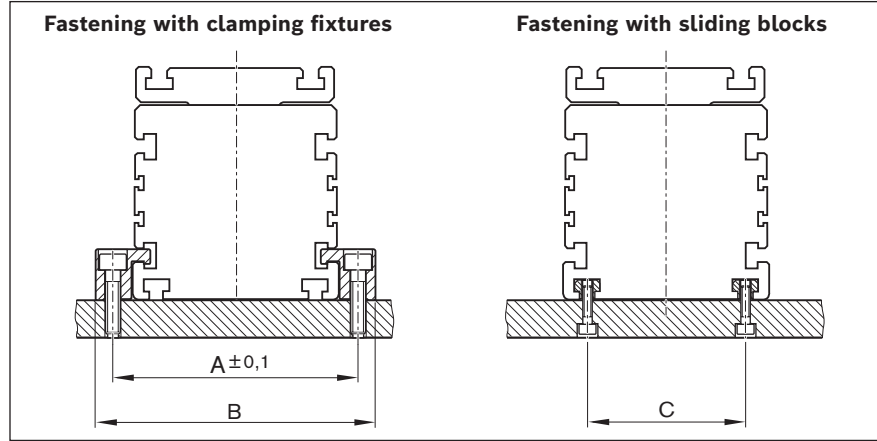

⚠ Do not mount or support the linear module by the end block, end enclosure or end plate! The frame is the load-bearing part!

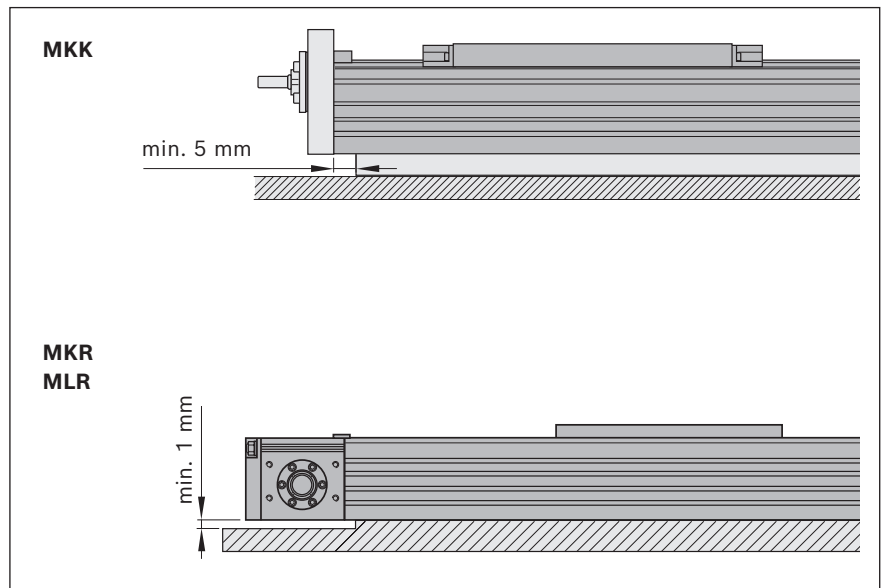

Clamping fixtures

Recommended number of clamping fixtures for linear modules -040:

- Type 1: 6 pieces per side/m
- Type 2: 4 pieces per side/m
- Type 3: 3 pieces per side/m

Recommended number of clamping fixtures for linear modules size -065 and up:

- Type 2: 3 pieces per meter and side

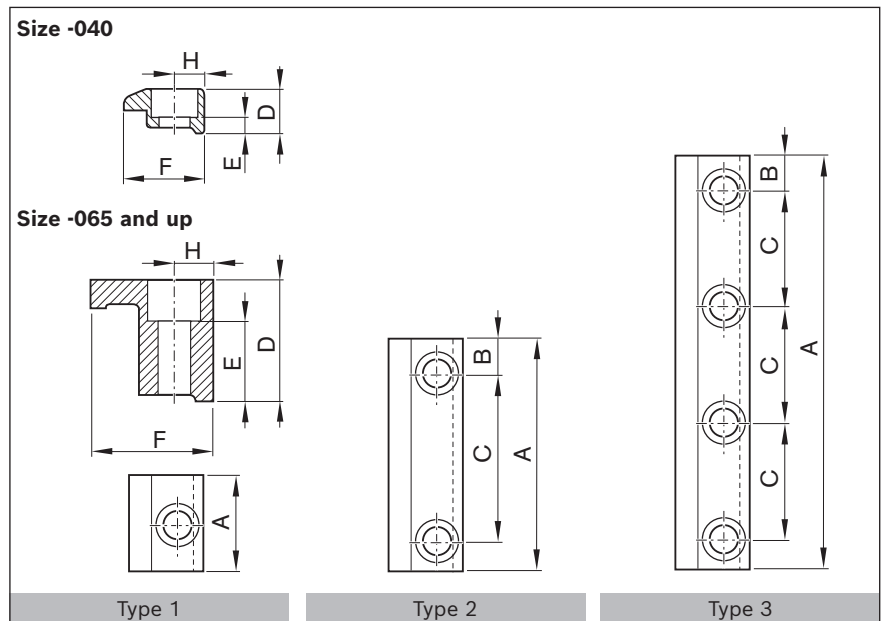

Size	Countersink ISO 4762 for	Type	Number of bores N	Dimensions (mm)							Material number	
				A	B	C	D	E	F	H		
-040	M5	1	1	22	-	-						R141901001
		2	2	57	8.5	40	10.0	4.8	15	6.5	R141901043	
		3	4	77	8.5	20					R141901044	
-065	M6	2	2	78	14.0	50	20.0	11.5	20	7.0	R117519024	
-080	M6			78	14.0	50	20.0	11.5	20	7.0	R117519024	
-110	M8			108	19.0	70	27.5	16.5	29	9.0	R117529026	
-140	M10			163	29.0	105	40.5	27.0	41	13.0	R117539014	
-165	M10			163	29.0	105	40.5	27.0	41	13.0	R117539014	
-145	M10			163	29.0	105	32.0	18.5	41	13.0	R117529044	

Mounting and fastening elements

Centering rings

The centering ring serves as a positioning aid and for positive locking when mounting customer-built attachments to the carriage and the frame. It creates a positive-locking connection with good reproducibility.
Material: Steel

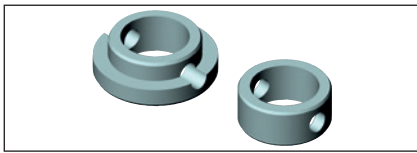
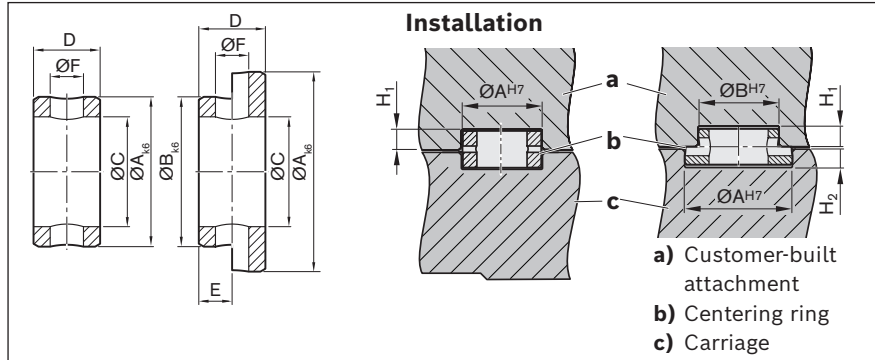

Ø Size (mm)	Dimensions (mm)									Material number
	A	B	C ±0.1	D -0.2	E +0.2	ØF	H ₁ +0.2	H ₂ +0.2		
5	5	-	3.4	3.0	-	1.6	1.6	-	R039660542	
7	7	-	5.5	3.0	-	1.6	1.6	-	R039660543	
9	9	-	6.6	4.0	-	2.0	2.1	-	R039660544	
12	12	-	9.0	4.0	-	2.0	2.1	-	R039660545	
16	16	-	11.0	6.0	-	3.0	3.1	-	R039660546	
7 - 5	7	5	3.4	3.0	1.5	1.6	1.6	1.6	R039660547	
9 - 5	9	5	3.4	3.5	1.5	1.6	2.1	1.6	R039660548	
9 - 7	9	7	5.5	3.5	1.5	1.6	2.1	1.6	R039660549	
12 - 9	12	9	6.6	4.0	2.0	2.0	2.1	2.1	R039660550	
16 - 12	16	12	9.0	5.0	2.0	2.0	2.1	3.1	R039660551	

Sliding blocks

Size	Dimensions (mm)							Material number
	A	B	C	D	E	F	G	
-110	13	6.0	10	8	-	13	M6 (1x)	R344700101 ^{*)}
					9	20	M6 (2x)	R039175003 ^{*)}
-140 / -145 -165	15	6.0	12	10	-	15	M6 (1x)	M6: R344700301 ^{*)}
					-	-	M8 (1x)	M8: R344700201 ^{*)}
					15	30	M8 (2x)	R039175004 ^{*)}
-	19	8.8	12	10	-	19	M10 (1x)	R344700601

^{*)} Profile as per DIN 508

Square nuts

Size	Dimensions (mm)			Material number
	A	B	C	
-065 / -080	8	4	M5	R913001655 per DIN 557
-110	13	4	M8	R344200301 per DIN 562
-140 / -145 / -165	16	8	M10	R344200200 per DIN 557

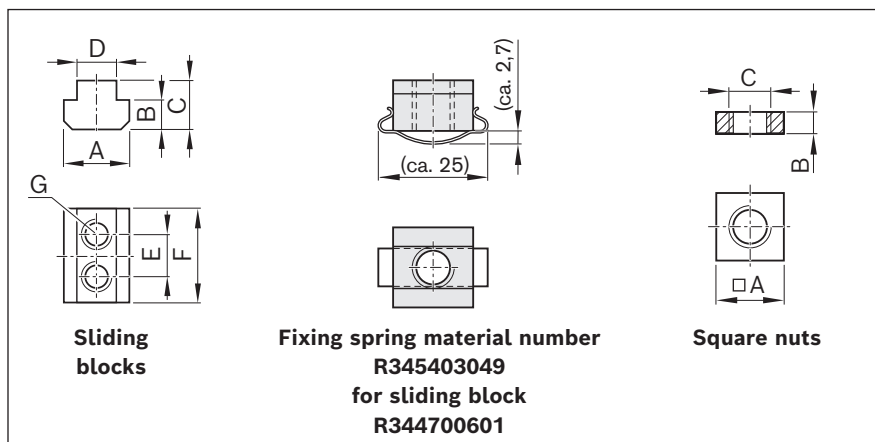

Sliding blocks

Fixing spring material number
R345403049
for sliding block
R344700601

Square nuts

Threaded strips

All threaded strips can be fixed in place for vertical installation.
 Suitable for corresponding T-slots at the linear module.
 Material: Steel, black finished

Example illustration
 (for more information, see dimension drawing)

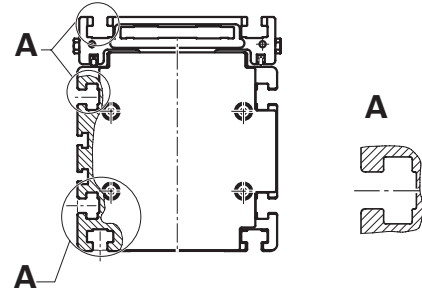

Size -080

Material number: R039171003

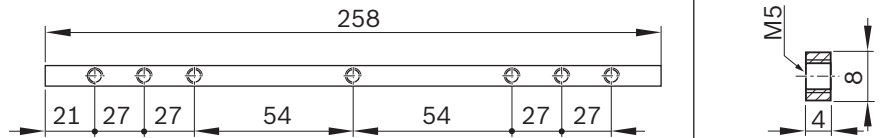

Size -110

Material number: R039171006*)

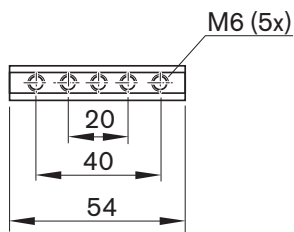

Material number: R039171001*)

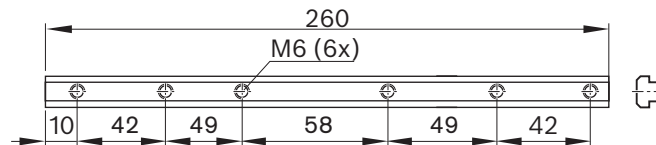

Material number: 2 R039171000*)

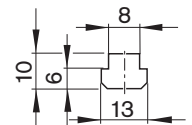
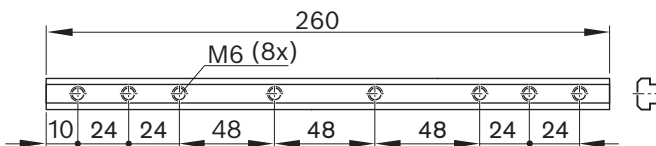

Sizes -140/-145/-165

Material number: R039171005*)

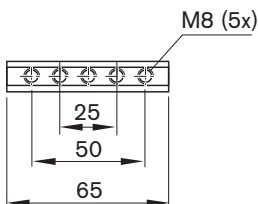

Size -165

Material number: R039171004*)

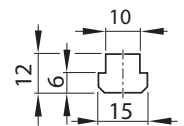
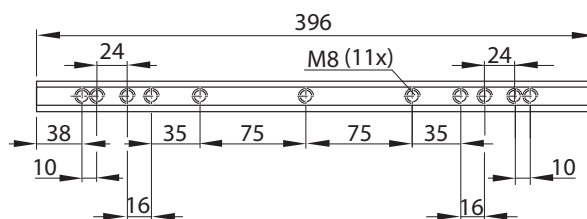

*) Profile as per DIN 508

Attachments and accessories

Connecting shafts

Steel connecting shafts with disk-pack coupling

(shaft 1, 2)

- Compensation of misalignments
- Backlash-free and torsionally stiff
- Bridge large distances between axes
- Dynamically balanced as per VDI 2060

Notes for horizontal installation position

(Vertical installation position on request)

Subject to alternative version with unchanged technical data.

Calculation of length L_{cs} for $i = 1$:

Shaft	Size	Length L_{cs} (mm)
1	-165	$L_M - 220$ mm
	-140	$L_M - 195$ mm
2	-110 / -145	$L_M - 140$ mm
	-080	$L_M - 120$ mm
3	-110 / -145	$L_M - 155$ mm
4	-080	$L_M - 144$ mm
5	-065	$L_M - 105$ mm
6	-040	$L_M - 55$ mm

Connecting shafts with flexible membrane coupling

(shaft 3 - 6)

- Compensation of misalignments
- Backlash-free and torsionally stiff
- Bridge large distances between axes
- Clamping hub (mounting and dismantling without shifting aligned axes)
- Dynamically balanced as per VDI 2060

⚠ Install guards to secure against contact with rotating parts during operation!
Comply with the laws on equipment safety and machinery safety regulations at all times!

Order

Please state the material number and length L_{cs} when ordering. Subject to alternative version with unchanged technical data.

L_{cs} = Overall length of the connecting shaft (mm)
 L_M = Centerline-to-centerline distance of the linear module (mm)

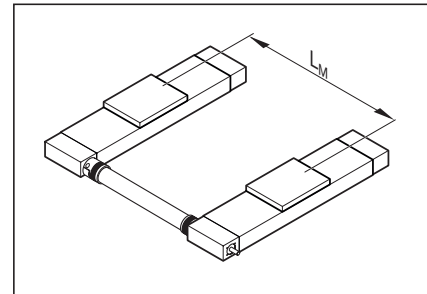

Critical speed as a function of overall length

n = Rotary speed (rpm)
 L_{cs} = Overall length of the connecting shaft (mm)

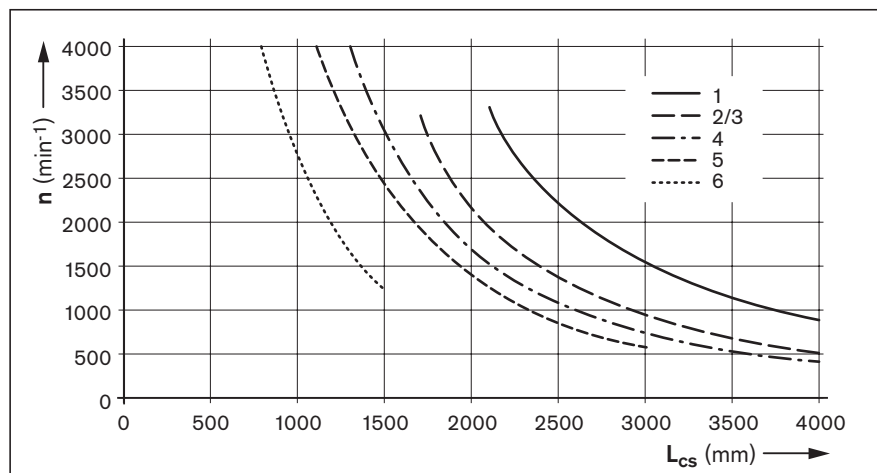

Dimension drawings

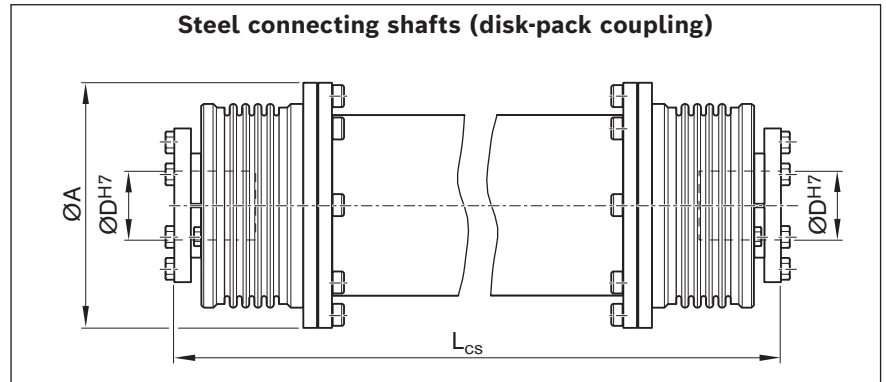

Material numbers and dimensions

Shaft	Size	Material number	Dimensions				Torque (Nm)	Weight (kg)	Flexibility		Mass moment of inertia (10 ⁻⁶ kg/m ²)
			A (mm)	D (mm)	L _{cs} min (mm)	L _{cs} max (mm)			Δk _a (mm)	Δk _w (°)	
1	-140/-165	R039151011	149	35	280	4,000	400	12.8 + 0.0115 • (L _{cs} - 180)	2.6	1	32,320 + 38.5 • (L _{cs} - 180)
2	-080/-110/-145	R039151012	110	18	250	4,000	100	4.2 + 0.008 • (L _{cs} - 160)	1.8	1	6,480 + 8.5 • (L _{cs} - 160)

Δk_a = axial flexibility (mm)
 Δk_w = angled flexibility (°)

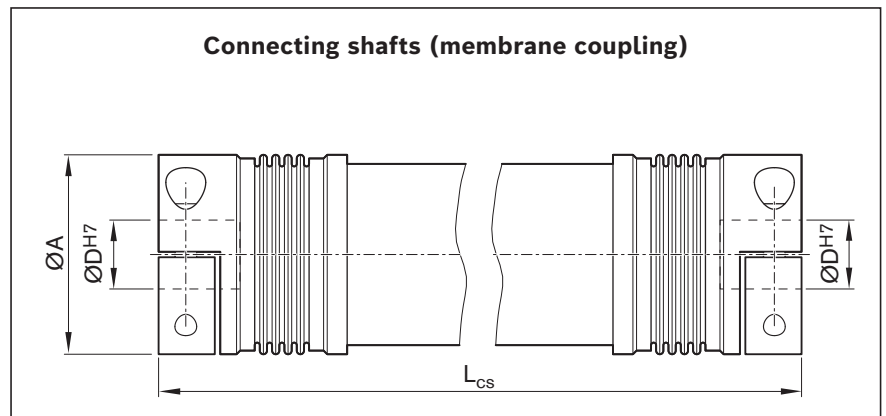

Material numbers and dimensions

Shaft	Size	Material number	Dimensions				Torque (Nm)	Weight (kg)	Mass moment of inertia (10 ⁻⁶ kg/m ²)
			A (mm)	D (mm)	L _{cs} min (mm)	L _{cs} max (mm)			
3	-110/-145	R039151013	81	18	200	4,000	150.0	2.00 + 0.00318 • (L _{cs} - 160)	2,000 + 4.5 • (L _{cs} - 160)
4	-080	R039151014	66	18	171	4,000	60.0	0.85 + 0.00145 • (L _{cs} - 120)	510 + 1.18 • (L _{cs} - 120)
5	-065	R039151015	55	16	148	3,000	25.0	0.62 + 0.0012 • (L _{cs} - 120)	245 + 0.663 • (L _{cs} - 120)
6	-040	R039151021	32	10	101	1,500	12.5	0.12 + 0.00054 • (L _{cs} - 80)	30 + 0.09 • (L _{cs} - 80)

Attachments and accessories

Nozzle pipe

For manual grease guns. For the lubrication of funnel-type and ball-type lube nipples.

Scope of delivery:

Nozzle pipe, interchangeable insert A for funnel-type lube nipple, interchangeable insert B for ball-type lube nipple.

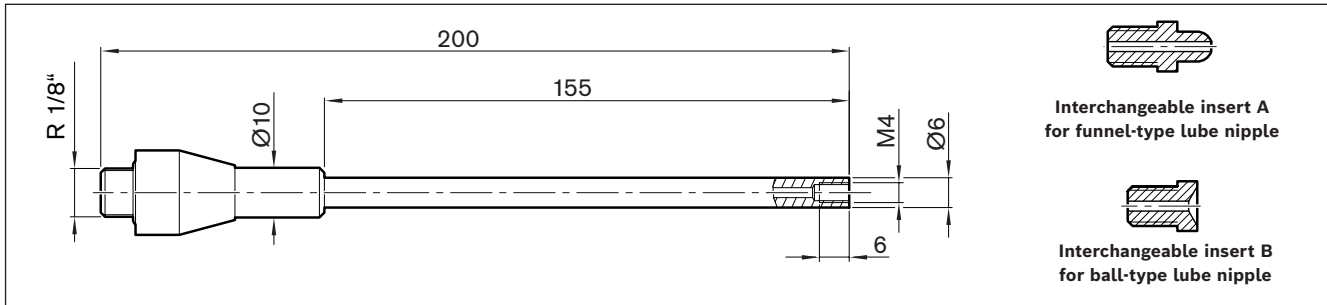

Material number	Mass (g)
R345503106	158

Frequency meter

for checking the toothed belt pretension on linear axes with a toothed belt drive as well as the adjustment of the toothed belt pretension when driven via a belt side drive.

The compact IGAT measuring device TECO-PRO enables easy measurement of the pretension of standard belt systems. Equipped with the latest microprocessor technology, the measuring device enables precise adjustment of all V-belts, toothed belts and power belts that need to be tensioned in the measuring range between 10 and 600 Hz. Belt construction, color and material of the belt as well as the influence of light have no effect on the measurement result because the acoustic principle is used.

Scope of delivery:

The device is delivered with a permanently installed gooseneck. A leather belt bag is included. The device is delivered with a USB charging cable and a euro plug in a sturdy hard box.



Material number
R913057897

Linear motion systems connection technology

Product description

In the past, machine manufacturers themselves have had to devise, design and manufacture systems for installing or mounting linear modules and for connecting linear modules with ball screw drives or toothed belt drives.

The Robotic Erector System for linear modules facilitates these tasks and therefore leads to savings for the user, since the system comprises mass-produced, standardized components.

The result: users can respond flexibly to the varied requirements and uses of linear motion technology.

The system provides various possibilities for constructing two or three axes from linear modules and connection elements.

The basic elements (plates and angles) have been designed to allow linear modules to be connected to other ones of the same size or one size larger or smaller.

The range also includes purpose-designed mounting accessories.

The linear modules and the connecting elements combine to form the Robotic Erector System for linear modules.

See the "Multi-axis systems" catalog for further information on the connection system.



Motors

Motor attachment kits according to customer specification

The motor attachment for linear motion systems with Rexroth ball screw assembly consists of either an attachment kit with flange and coupling (MF) or a belt side drive (SD).

The available combinations are shown in the "Configuration and ordering" selection tables for each size.

In addition to attachment kits for Rexroth motors, attachment kits for motors according to customer specification are also available. In order to determine the appropriate attachment kit, the connection geometry of the motor is crucial. Characteristics required to clearly determine motor geometry are shown below.

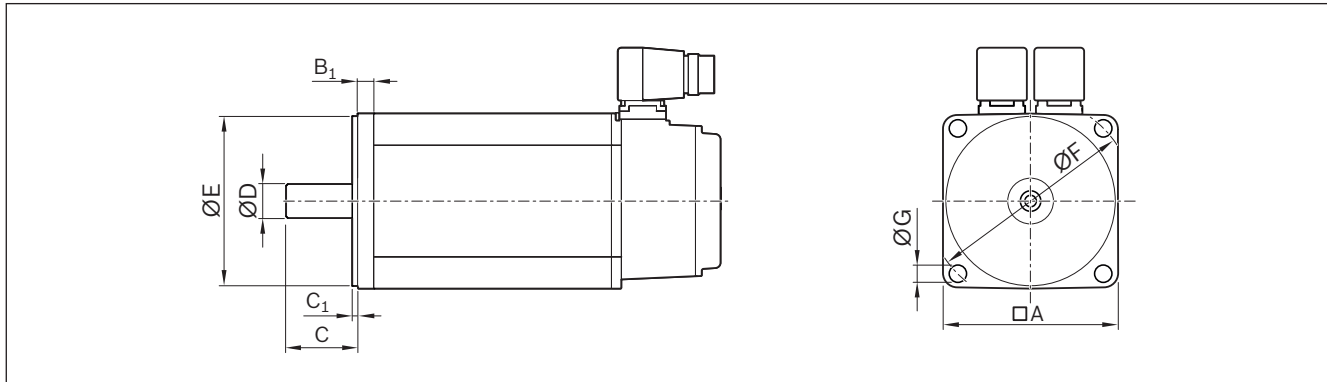

The dimensions queried result in a unique "motor geometry code":

	□□	-	□□	-	□□□	-	□□□	-	□□□	-	M□□	-	□□□	-	□□□
ØD	=	Shaft diameter													
C	=	Shaft length													
ØE	=	Centering diameter													
C ₁	=	Centering depth													
ØF	=	Pitch diameter													
ØG	=	Drill hole for fastening screw (specify thread diameter)													
B ₁	=	Flange thickness													
A	=	Flange edge dimension													

Example illustration of servo motor IndraDyn S type MS2N04

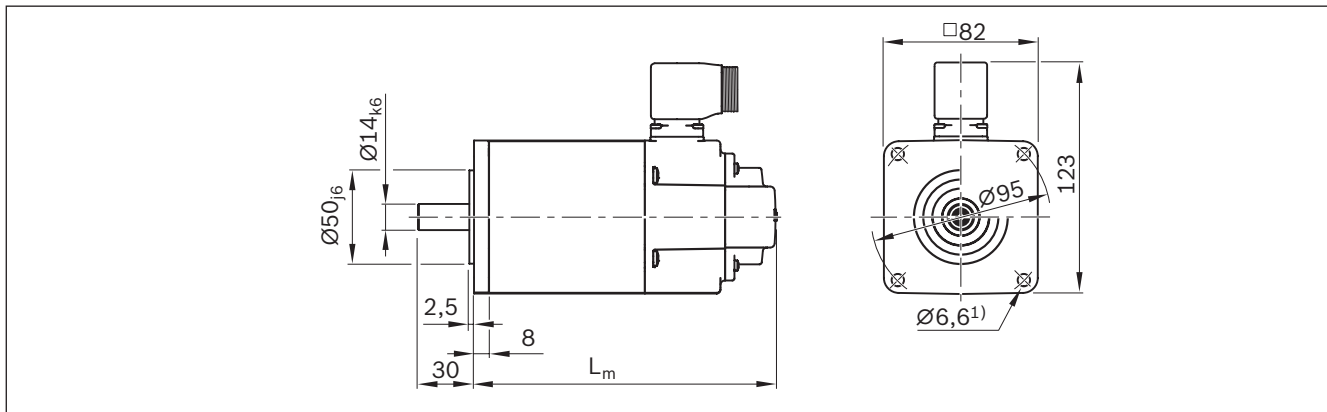

1 4 - 3 0 - 0 5 0 - 2 . 5 - 0 9 5 - M 0 6 - 0 0 8 - 0 8 2

¹⁾ The drill hole Ø 6.6 mm results in the type designation M06 (nominal thread diameter of M6 fixing screw) for the geometry motor code.

Motor attachment kits for motors according to customer specification can be selected using the online configurator in the eShop. To do this, select the "mechanical interface" and "motors according to customer specification" option.

Size of customer motor

Motor manufacturer ▼

Motor type ▼

Side view technical drawing of a motor. Dimensions shown: B1: ??? mm (width of the mounting flange), Ø E: ??? mm (total height), Ø D: ??? mm (height of the motor body), C1: ??? mm (width of the motor body), and C: ??? mm (total width).

Top view technical drawing of a motor. Dimensions shown: A: ??? mm (square mounting plate side length), Ø F: ??? mm (outer diameter of the motor body), and Ø G: ??? mm (inner diameter of the mounting plate).

Example

Size of customer motor

Motor manufacturer ▼

Motor type ▼

Side view technical drawing of a Siemens 1FK706 motor. Dimensions shown: B1: 10 mm, Ø E: 110 mm, Ø D: 24 mm, C1: 3,5 mm, and C: 50 mm.

Top view technical drawing of a Siemens 1FK706 motor. Dimensions shown: A: 126 mm (square mounting plate side length), Ø F: 130 mm (outer diameter of the motor body), and Ø G: for M8 (inner diameter of the mounting plate).

IndraDyn S - Servo motors MSM

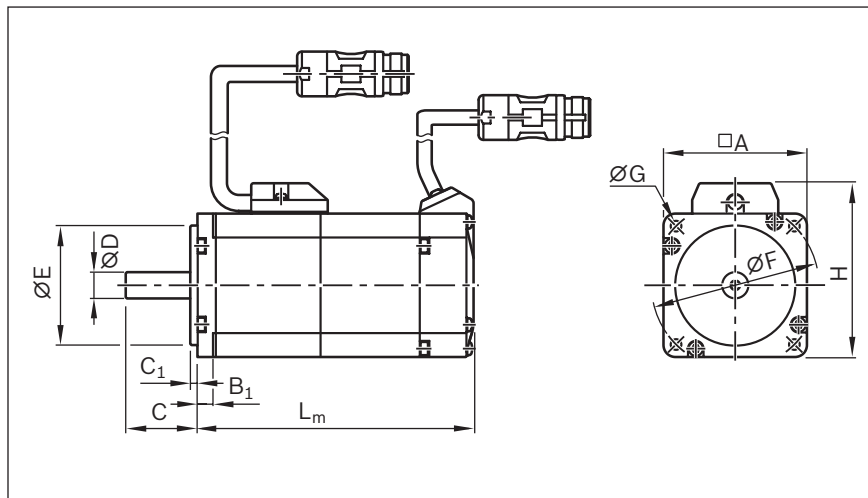

Motor schematic

Motor code	Dimensions (mm)										
	A	B ₁	C	C ₁	∅ D _{h6}	∅ E _{h7}	∅ F	∅ G	H	L _m	
										without	with
MSM 019B-0300	38	6.0	25	3	8	30	45	3.4	51	92.0	122.0
MSM 031B-0300	60	6.5	30	3	11	50	70	4.5	73	79.0	115.5
MSM 031C-0300	60	6.5	30	3	14	50	70	4.5	73	98.5	135.0
MSM 041B-0300	80	8.0	35	3	19	70	90	6.0	93	112.0	149.0

Version:

- ▶ Plain shaft without shaft seal
- ▶ M5 multi-turn absolute encoder (20-bit, absolute encoder function only available with backup battery)
- ▶ Cooling system: natural convection
- ▶ IP54 protection class (shaft IP40)
- ▶ With or without holding brake
- ▶ M17 metal round connector

Note

The motors are available with controllers and control systems. For more information on motors, controllers and control systems, please refer to the Rexroth automation solutions ➡ Chapter "Further information"

Motor data										Motor connection	Brake	Type code	Material number
n_{max} (rpm)	M_0 (Nm)	M_{max} (Nm)	M_{br} (Nm)	J_m (kg/m ²)	J_{br} (kg/m ²)	m_m (kg)	m_{br} (kg)						
5,000	0.32	0.95	0.29	0.0000051	0.0000002	0.47	0.21	2	N	MSM 019B-0300-NN-M5-MH0	R911344211		
									Y	MSM 019B-0300-NN-M5-MH1	R911344212		
5,000	0.64	1.91	1.27	0.0000140	0.0000018	0.82	0.48	2	N	MSM 031B-0300-NN-M5-MH0	R911344213		
									Y	MSM 031B-0300-NN-M5-MH1	R911344214		
5,000	1.30	3.80	1.27	0.0000260	0.0000018	1.20	0.50	2	N	MSM 031C-0300-NN-M5-MH0	R911344215		
									Y	MSM 031C-0300-NN-M5-MH1	R911344216		
4,500	2.40	7.10	2.45	0.0000870	0.0000075	2.30	0.80	2	N	MSM 041B-0300-NN-M5-MH0	R911344217		
									Y	MSM 041B-0300-NN-M5-MH1	R911344218		

Motor characteristic

(Schematic)

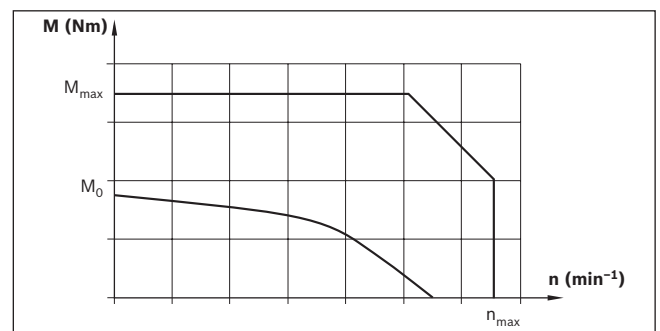

Motors

IndraDyn S - Servo motors MS2N

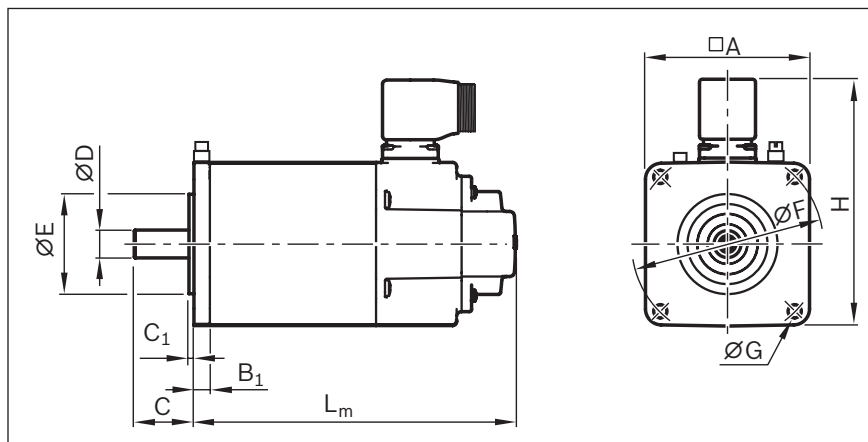
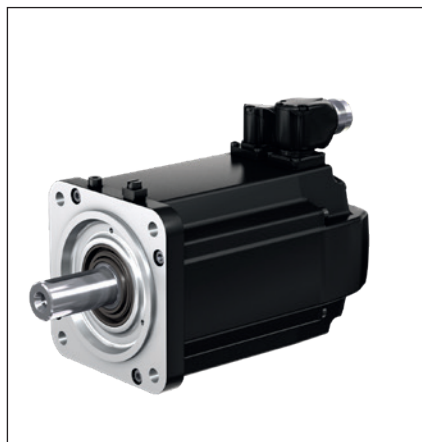

Motor schematic

Dimensions / motor data

Motor code	Dimensions (mm)												
	□ A	B ₁	C	C ₁	∅ D _{k6}	∅ E _{j7}	∅ F	∅ G	Cables 2	1	H Brake without	with	L _m
MS2N03-B0BYN	58	7.5	20	2.5	9	40	63	4.5	84	99	163	192	
MS2N03-D0BYN	58	7.5	23	2.5	11	40	63	4.5	84	99	203	232	
MS2N04-B0BTN	82	8	30	2.5	14	50	95	6.6	108	123	162	194.5	
MS2N04-C0BTN	82	8	30	2.5	14	50	95	6.6	108	123	194	226.5	
MS2N04-D0BQN	82	8	30	2.5	14	50	95	6.6	108	123	226	258.5	
MS2N05-B0BTN	98	9	40	3	19	95	115	9	124	139	188	218	
MS2N05-C0BTN	98	9	40	3	19	95	115	9	124	139	224	254	
MS2N05-D0BRN	98	9	40	3	19	95	115	9	124	139	260	290	
MS2N06-B1BNN	116	14	50	3	24	95	130	9	156	156	164	201	
MS2N06-C0BTN	116	14	50	3	24	95	130	9	156	156	184	202	
MS2N06-D0BRN	116	14	50	3	24	95	130	9	156	156	224	261	
MS2N06-D1BNN	116	14	50	3	24	95	130	9	156	156	224	261	
MS2N07-B1BNN	140	18	58	4	32	130	165	11	180	180	176	230	
MS2N07-C0BQN	140	18	58	4	32	130	165	11	180	180	205	259	
MS2N07-C1BRN	140	18	58	4	32	130	165	11	180	180	205	259	
MS2N07-D1BNN	140	18	58	4	32	130	165	11	180	180	263	317	

Version

- ▶ Plain shaft without shaft seal ring
- ▶ Multi-turn encoder
- ▶ Advanced encoder (B) in conjunction with 1-cable connector (AcuroLink interface)
- ▶ IP64 protection class
- ▶ With or without holding brake
- ▶ Special ground connection terminal near motor flange (used as needed)

Note

The motors are available with controllers and control systems. For more information on motors, controllers and control systems, please refer to the Rexroth automation solutions ➔ Chapter "Further information"

Motor data									Motor connection	Brake	Type code	Material number
n_{max} (rpm)	M_0 (Nm)	M_{max} (Nm)	M_{br} (Nm)	J_m (kg/m ²)	J_{br} (kg/m ²)	m_m (kg)	m_{br} (kg)					
9,000	0.73	3.46	1.8	0.000023	0.000007	1.4	0.4	1	N	MS2N03-B0BYN-CMSH0-NNNNE-NN	R911384767	
								1	Y	MS2N03-B0BYN-CMSH1-NNNNE-NN	R911384769	
9,000	1.15	6.8	1.8	0.000037	0.000007	2.0	0.4	1	N	MS2N03-D0BYN-CMSH0-NNNNE-NN	R911384772	
								1	Y	MS2N03-D0BYN-CMSH1-NNNNE-NN	R911384773	
6,000	1.75	5.9	5.0	0.000070	0.000040	2.7	0.7	1	N	MS2N04-B0BTN-CMSH0-NNNNE-NN	R911384527	
								1	Y	MS2N04-B0BTN-CMSH1-NNNNE-NN	R911384528	
6,000	2.80	12.0	5.0	0.000110	0.000050	3.7	0.7	1	N	MS2N04-C0BTN-CMSH0-NNNNE-NN	R911384531	
								1	Y	MS2N04-C0BTN-CMSH1-NNNNE-NN	R911384532	
6,000	3.85	18.1	5.0	0.000160	0.000040	4.7	0.7	1	N	MS2N04-D0BQN-CMSH0-NNNNE-NN	R911384535	
								1	Y	MS2N04-D0BQN-CMSH1-NNNNE-NN	R911384536	
6,000	3.75	10.6	10.0	0.000170	0.000110	4.0	1.1	1	N	MS2N05-B0BTN-CMSH0-NNNNE-NN	R911384542	
								1	Y	MS2N05-B0BTN-CMSH1-NNNNE-NN	R911384543	
6,000	6.10	20.8	10.0	0.000290	0.000110	5.9	1.1	1	N	MS2N05-C0BTN-CMSH0-NNNNE-NN	R911384546	
								1	Y	MS2N05-C0BTN-CMSH1-NNNNE-NN	R911384547	
6,000	7.90	31.3	10.0	0.000400	0.000110	7.3	1.1	1	N	MS2N05-D0BRN-CMSH0-NNNNE-NN	R911384550	
								1	Y	MS2N05-D0BRN-CMSH1-NNNNE-NN	R911384551	
6,000	3.25	9.5	10.0	0.000480	0.000110	5.1	1.1	1	N	MS2N06-B1BNN-CMSH0-NNNNE-NN	R911384929	
								1	Y	MS2N06-B1BNN-CMSH1-NNNNE-NN	R911384930	
6,000	6.00	16.0	10.0	0.000390	0.000110	6.4	1.0	1	N	MS2N06-C0BTN-CMSH0-NNNNE-NN	R911384933	
								1	Y	MS2N06-C0BTN-CMSH1-NNNNE-NN	R911384934	
6,000	9.70	32.0	15.0	0.000650	0.000140	9.0	1.5	1	N	MS2N06-D0BRN-CMSH0-NNNNE-NN	R911384937	
								1	Y	MS2N06-D0BRN-CMSH2-NNNNE-NN	R911384938	
6,000	9.00	38.4	15.0	0.001400	0.000140	9.0	1.5	1	N	MS2N06-D1BNN-CMSH0-NNNNE-NN	R911384941	
								1	Y	MS2N06-D1BNN-CMSH2-NNNNE-NN	R911384942	
6,000	7.40	21.0	20.0	0.001970	0.000260	9.5	2.0	1	N	MS2N07-B1BNN-CMSH0-NNNNE-NN	R911384951	
								1	Y	MS2N07-B1BNN-CMSH1-NNNNE-NN	R911384952	
6,000	12.8	35.7	20.0	0.001200	0.000260	12.0	2.0	1	N	MS2N07-C0BQN-CMSH0-NNNNE-NN	R911384955	
								1	Y	MS2N07-C0BQN-CMSH1-NNNNE-NN	R911384956	
6,000	11.50	42.2	20.0	0.003050	0.000260	12.0	2.0	1	N	MS2N07-C1BRN-CMSH0-NNNNE-NN	R911384959	
								1	Y	MS2N07-C1BRN-CMSH1-NNNNE-NN	R911384960	
6,000	18.90	84.8	36.0	0.005290	0.000410	17.5	2.5	1	N	MS2N07-D1BNN-CMSH0-NNNNE-NN	R911384965	
								1	Y	MS2N07-D1BNN-CMSH2-NNNNE-NN	R911384966	

122 Linear modules

Automation package

3 ORDERING OPTIONS

- ▶ Single axis
- ▶ Single axis + drive (incl. mains filter/cable (optional))
- ▶ Single axis + drive + software (incl. mains filter/cable (optional)) as plug & play complete solution

Ordering options	System	Options					Further information	
		Motor MS2N	Drive controller		Cable	Mains filter		Software
			Indra-Drive HCS	ctrlX Drive				
1	CKK / CKR	—	—	—	—	—	—	
	MKK / MKR	✓	—	—	—	—	—	
2	EMC	✓	✓	—	Optional	Included	—	
	EMC-HP	—	—	✓	Optional	Included	—	
3		✓	—	✓	Optional	Included	Optional	SFK-H ¹⁾

¹⁾ Further related information ➔ Smart Function Kit Handling (SFK-H)

Motor/controller combinations

Several motor-controller combinations are available in order to provide the most cost-effective solution for every customer application. When dimensioning the drive, always consider the motor-controller combination.

For more information on motors, controllers and control systems, please refer to the Rexroth automation solutions

➔ Chapter "Further information".

IndraDrive drive family

The converters of the IndraDrive C series generate a DC link direct voltage from the grid supply voltage and from it a controlled AC output voltage with variable amplitude and frequency for operation of a servo motor.

The compact format contains additional mains connection components, making it particularly suitable for single-axis applications.

Version

- ▶ Basic Universal or Basic Universal with Safe Motion
- ▶ Multi-Ethernet for communication with a superior controller
- ▶ More interfaces or integrated controls available
- ▶ For the converter HCS01, a smart function kit for pressing and joining applications is available
- ▶ Brake resistor included
- ▶ Adapters included
- ▶ Separate mains filter included



IndraDrive Cs
HCS01.1E-W0054



IndraDrive C
HCS03.1E-W0100

ctrlX drive family

With ctrlX DRIVE, Bosch Rexroth has developed the most compact, modular drive system worldwide for their customers. In addition to space-saving dimensions and maximum scalability, an almost unlimited number of combination options for the user, mature engineering tools and high energy efficiency are among the advantages of ctrlX DRIVE. The Bosch Rexroth servo motors are the perfect team players in the ctrlX DRIVE portfolio.

With compact dimensions, they combine highest dynamics with maximum accuracy for the position, rotary speed and torque values.

- ▶ EtherCAT SOE with Safe Torque Off or EtherCAT SOE with safe field bus
- ▶ Multi-Ethernet for communication with a superior controller
- ▶ More interfaces or integrated controls available
- ▶ Adapters included
- ▶ Separate mains filter included



ctrlX Drive (XCS)

124 Linear modules

Automation package

Motor-controller combinations

Motor			Drive controller				
	Brake			Without controller	Controller option		
	Without	With			HCS	Controller option	
					BASIC		
					UNIVERSAL		
					MultiEthernet		
					(B-ET) + L3	(B-ET) + S4	
					Safe torque off	Safe motion	
Without motor	000			Without	000	000	
Motor not listed							
MS2N03-B0BYN-CMSHx	203	204	1 cable	000	HCS01-W0008	102	101
MS2N03-D0BYN-CMSHx	207	208			HCS01-W0018	302	301
MS2N04-B0BTN-CMSHx	211	212					
MS2N04-C0BTN-CMSHx	215	216					
MS2N04-D0BQN-CMSHx	219	220					
MS2N05-B0BTN-CMSHx	223	224					
MS2N05-C0BTN-CMSHx	227	228					
MS2N05-D0BRN-CMSHx	231	232			HCS01-W0028	402	401
MS2N06-B1BNN-CMSHx	235	236			HCS01-W0008	102	101
MS2N06-C0BTN-CMSHx	239	240			HCS01-W0028	402	401
MS2N06-D0BRN-CMSHx	243	244					
MS2N06-E0BRN-CMSHx	251	252					
MS2N07-B1BNN-CMSHx	255	256					
MS2N07-C0BQN-CMSHx	259	260			HCS01-W0018	302	301
MS2N07-D1BNN-CMSHx	269	270			HCS01-W0028	402	401
MS2N07-D0BHA-CMVHx	287	288			HCS01-W0054	502	501
MS2N07-D0BRN-CMVHx	295	296					
MS2N07-E1BNN-CMVHx	299	300					
MS2N07-E0BQN-CMVHx	297	298					
MS2N10-C0BNN-CMVHx	289	290			2 cables	HCS03-W0100	702
MS2N10-D0BHA-CMVHx	291	292	HCS01-W0054	502		501	
MS2N10-E0BHA-CMAHx	293	294	HCS03-W0100	702		701	



The table lists motors that might not be used with this product.

¹⁾ Further related information → Smart Function Kit Handling (SFK-H)

	XCS2	Controller option				Without	Cable option											
	MultiEthernet				Controller HCS / XCS2													
	CAT SOE		SOE ¹⁾		1 cable			2 cables										
	+ T0	+FSoE + M5	+core +Software_SFK T0	+FSoE +core +Software_SFK M5	5 m		10 m	15 m	5 m	10 m	15 m							
	Safe torque off	Safe motion	Safe torque off	Safe motion														
	Without	000	000	000	000	000	000	000	000	000	000	000						
XCS2-W0023	2100	In preparation	2160	2161	-	105	110	115	-	-	-	-						
XCS2-W0054	3100		3160	3161														
XCS2-W0023	2100		2160	2161														
XCS2-W0054	3100		3160	3161														
XCS2-W0023	2100		2160	2161														
XCS2-W0054	3100		3160	3161														
XCS2-W0070	4100		-	-									-	-	-	205	210	215
XCS2-W0054	3100		3160	3161														
XCS2-W0070	4100		-	-														
XCS2-W0100	5100		-	-														

Motor-controller-cable combinations

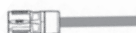
Hybrid cable (power and encoder cable combined, 1 cable)

Motor	Drive controller	Technical data						
		Cable designation Part number	Cable weight (approximately) kg/m	Cable outside diameter D (mm)	Bending radius minimum		Bending cycle	
					Fixed installation	Flexible installation		
MS2N03-B0BYN-CMSHx	HCS01.1E-W0008	RH2-021DBB-NN-xxx,x	0.26	13.0 +/- 0.3	5 x D	7.5 x D	> 5 mill.	
MS2N06-B1BNN-CMSHx		5m R911372050 10m R911372052 15m R911372053						
MS2N03-D0BYN-CMSHx		HCS01.1E-W0018						
MS2N04-B0BTN-CMSHx								
MS2N04-C0BTN-CMSHx								
MS2N04-D0BQN-CMSHx								
MS2N05-B0BTN-CMSHx								
MS2N07-B1BNN-CMSHx								
MS2N05-C0BTN-CMSHx	HCS01.1E-W0028	5m R911372062 10m R911372064 15m R911372065						
MS2N05-D0BRN-CMSHx								
MS2N06-C0BTN-CMSHx								
MS2N06-D0BRN-CMSHx								
MS2N06-D1BNN-CMSHx								
MS2N07-C0BQN-CMSHx								
MS2N06-E0BRN-CMSHx	HCS01.1E-W0054	RH2-024DBB-NN-xxx,x						
MS2N07-C1BRN-CMSHx		5m R911374454 10m R911379794 15m R911379795						
MS2N07-D1BNN-CMSHx								
MS2N03-B0BYN-CMSHx	XCS2-W0023	RHB2-021DCB-NN-xxx,x	0.27	13.0 +/- 0.3	5 x D	7.5 x D	> 5 mill.	
MS2N03-D0BYN-CMSHx								
MS2N04-B0BTN-CMSHx								
MS2N04-C0BTN-CMSHx								
MS2N04-D0BQN-CMSHx								
MS2N05-B0BTN-CMSHx								
MS2N05-C0BTN-CMSHx								
MS2N05-D0BRN-CMSHx								
MS2N06-B1BNN-CMSHx								
MS2N06-C0BTN-CMSHx								
MS2N06-D1BNN-CMSHx								
MS2N07-B1BNN-CMSHx								
MS2N07-C0BQN-CMSHx	XCS2-W0054	RHB2-022DCB-NN-xxx,x						
MS2N06-D0BRN-CMSHx			5m R914508036 10m R914508046 15m R914508052					
MS2N06-E0BRN-CMSHx								
MS2N07-C1BRN-CMSHx								
MS2N07-D1BNN-CMSHx								

The table lists motors that might not be used with this product.







Motor-controller-cable combinations

Power and encoder cable separate, 2 cables

Motor	Drive controller	Technical data power cable					
		Cable designation Part number	Cable weight (approximately) kg/m	Cable outside diameter D (mm)	Bending radius minimum		Bending cycle
					Fixed installation	Flexible installation	
MS2N07-D0BHA-CMVHx MS2N07-E1BNN-CMVHx	HCS01.1E-W0054	RL2-044DBB-NN-xxx,x 5m R911374900 10m R911379527 15m R911379528	0.23	12.2 +/- 0.5			
MS2N07-D0BRN-CMVHx MS2N10-C0BNN-CMVHx MS2N10-D0BHA-CMVHx	HCS01.1E-W0054	RL2-044EBB-NN-xxx,x 5m R911374902 10m R911384595 15m R911384596	0.33	14.8 +/- 0.5	5 x D	7.5 x D	> 5 mill.
MS2N07-E0BQN-CMVHx	HCS03.1E-W0100	RL2-046EBB-NN-xxx,x 5 m R911376628 10m R911376666 15m R911376667					
MS2N10-E0BHA-CMAHx	HCS03.1E-W0100	RL2-066HBB-NN-xxx,x 5m R911373948 10m R911375037 15m R911375038	0.84	22.2 +/- 1.0			
MS2N07-D0BHA-CMVHx	XCS2-W0054	RLB2-042DBB-NN-xxx,x 5m R911397223	0.23	12.2 +/- 0.5			
MS2N07-E1BNN-CMVHx	XCS2-W0070	10m R911397225 15m R911397226					
MS2N07-D0BRN-CMVHx MS2N10-C0BNN-CMVHx	XCS2-W0054	RLB2-042ECB-NN-xxx,x 5m R911396693	0.33	14.8 +/- 0.5	5 x D	7.5 x D	> 5 mill.
MS2N07-E0BQN-CMVHx	XCS2-W0070	10m R911396695 15m R911396696					
MS2N10-D0BHA-CMVHx	XCS2-W0070	RLB2-042GDB-NN-xxx,x 5m R911397170 10m R911397173 15m R911397174"	0.58	18.2 +/- 0.6			
MS2N10-E0BHA-CMAHx	XCS2-W0100	RLB2-063HDB-NN-xxx,x 5m R911395186 10m R911395188 15m R911395189"	0.84	22.2 +/- 1.0			

The table lists motors that might not be used with this product.

Technical data encoder cable							
Cable designation Part number	Cable weight (approximately) kg/m	Cable outside diameter D (mm)	Bending radius minimum		Bending cycle		
			Fixed installation	Flexible installation			
 RG2-002AAB-NN-XXX,X 5 m R911371232 10m R911371935 15m R911371936	0.08	7.2 +/-0.2	4 x D	7.5 x D	> 5 mill.		
 RG2-007AAB-NN-XXX,X 5m R911382615 10m R911382617 15m R911382618							

130 Linear modules

Type designation

MS2N05 type designation / features (example)

		MS2N 05 - C 0 B N N - A S D H 0 - N N N N - N N															
1	Product																
2	Size																
3	Overall length																
4	Rotor inertia																Special version 17
5	Winding																Other version 16
6	Cooling type																Coating 15
7	Encoder performance																Format 14
8	Encoder version																Bearings 13
9	Electrical connection																Flange accuracy 12
																	Holding brake 11
																	Shaft 10

Description / options

1	Product	MS2N
2	Size	05
3	Overall length	B, C, D, E
4	Rotor inertia	0 = low inertia / 1 = mean inertia
5	Winding	BY = 9000 1/min / BT = 6000 1/min / BR = 4500 1/min / BQ = 4000 1/min BN = 3000 1/min / BH = 2000 1/min
6	Cooling type	N = self-cooling / A = external cooling axial 230 V/50 Hz
7	Encoder performance	Basic - 16 signal periods, Hiperface® = A Standard - 128 signal periods, Hiperface® (SIL2, PL d)= B Advanced - 20-bit, ACURO®Link (SIL2, PL d)= C Advanced - 20-bit, ACURO®Link (SIL2, PL e)= H
8	Encoder version	Single-turn - 1 revolution absolute = S Multi-turn - 4096 revolutions absolute = M
9	Electrical connection	Two-cable connection 2x M17, rotatable = D Single-cable connection M17, rotatable = H Single-cable connection M23, rotatable = S
10	Shaft	Smooth, without shaft seal ring = H / Smooth, with shaft seal ring = G Keyway, half-spine balancing without shaft seal ring = L Keyway, half-spine balancing with shaft seal ring = K
11	Holding brake	Without holding brake = 0 / size 1, electrically releasing = 1
12	Flange accuracy	Standard = N
13	Bearings	Standard bearing = N
14	Format	B5 / IM3001, PT1000 = N
15	Coating	Standard painting RAL 9005 black = N
16	Other version	None = N / Additional earthing connection = E / Sealing air connection = P
17	Special version	None = NN

► Further information on MS2N synchronous servo motors ➡ Chapter "Further information"

Type designation controller HCS01 (example)

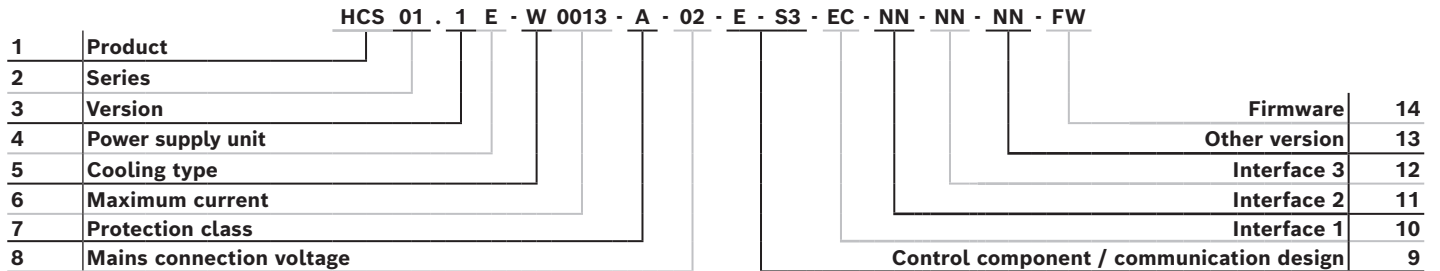

Description / options

1	Product	HCS
2	Series	01
3	Version	1
4	Power supply unit	E = infeed
5	Cooling type	W = air, internal
6	Maximum current	02:0003 = 3 A / 0006 = 6 A / 0009 = 9 A / 0013 = 13 A / 0018 = 18 A 03: 0005 = 5 A / 0008 = 8 A / 0018 = 8 A / 0028 = 28 A / 0054 = 54 A
7	Protection class	A = IP20
8	Mains connection voltage	02 = 3 x AC 110...230 V / 03 = 3 x AC 200...500 V
9	Control component version Communication	A-CC = Advanced Sercos III Master / B-ET = Basic Multi-Ethernet/ E-S3 = Economy Sercos III
11	Interface 1	EC = Encoder IndraDyn / Hiperface / 1VSS / TTL / Endat 2.1/2.2
12	Interface 2	CN = CANopen / EC = Multi-encoder interface / EM = Encoder emulation / ET = Multi-Ethernet NN = Not equipped / PB = PROFIBUS
13	Interface 3	L3 = STO (Safe Torque Off) L4 = STO (Safe Torque Off) and SBC (Safe Brake Control) NN = Not equipped / S4 = Safe Motion
14	Other version	NN = None
15	Firmware	

► Further information on the controller ➡ Chapter "Further information"

132 Linear modules

Type designation

Type designation controller XCS2 (example)

	XCS2	-	W	0100	A	B	N	-	01	N	ET	TO	EC	NN	-	S	03	RS	N	1	NNN	N	0	NN		
1	Product																								Other Version	21
2	Cooling type																								Range of functions SM	20
3	Maximum current																								Range of functions RT	19
4	Protection class																								Technology function	18
5	Power unit options																								Protocol - communication	17
6	Connector set																								Subject to export approval	16
7	Control component																								Runtime release	15
8	Panel																								Runtime version	14
9	Communication																								Runtime type	13
10	Hardware option 1																								Hardware option 3	12
11	Hardware option 2																									

Description / options

1	Product	1: X = ctrlX DRIVE / 2: C = converter, feed-in / 3: S = single axis / 4: 2 = generation 2; 1 = generation 1
2	Cooling type	W = air, internal
3	Maximum current	0100 = 100 A (example) / 23, 54, 70, 100 ...
4	Protection class	A = IP20, 3 x AC 200...500 V
5	Power unit options	B = Brake transistor (XCS ≥ W0100) / R = Brake transistor/brake resistor integrated (XCS ≤ W0070)
6	Connector set	N = Without motor connector set
7	Control component	01 = ctrlX DRIVE / 02 = ctrlX DRIVEplus
8	Panel	N = Without panel / A = With panel
9	Communication	ET = Multi-Ethernet (RJ45) / X3 = ctrlX Core
10	Hardware option 1	TO = Safe Torque Off (STO) / M5 = SafeMotion (M5)
11	Hardware option 2	EC = Multi-encoder interface / NN = Not equipped
12	Hardware option 3	ET = Multi-Ethernet / DA = I/O extension digital/analog / NN = Not equipped
13	Runtime type	S = Standard
14	Runtime version	02 = Version 02 (XCS1) / 03 = Version 03 (XCS2)
15	Runtime release	RS = Current release
16	Subject to export approval	N = No (maximum output frequency < 599 Hz)
17	Protocol - communication	0 = Defined via ctrlX CORE apps (XCS2) 1 = Sercos III / 2 = EtherCAT (SoE) / 4 = PROFINET IO
18	Technology function	NNN = None TF1 = Install technology apps (XCS2) TE1 = Install/program technology apps (XCS2) TX1 = Install/program technology apps incl. LIBs (Bosch Rexroth libraries) (XCS2)
19	Range of functions RT	N = DRIVE Runtime P = DRIVE Runtime Productivity
20	Range of functions SafeMotion	0 = Hardware option / 1 ≠ SafeMotion 3 = SafeMotion Speed / 5 = SafeMotion Position
21	Other Version	NN = No

► Further information on the controller ➡ Chapter "Further information"

Mains filter



Controller / mains filter option						
Controller	Option	Weight (kg)	Mains filter			
			Option	Weight (kg)	Material number	
HCS01-W0008	100 / 101 / 102	1.3	NFD03.1-480-007	007	0.88	R911286917
HCS01-W0018	300 / 301 / 302	2.1	NFD03.1-480-007	007	0.88	R911286917
HCS01-W0028	400 / 401 / 402	2.1	NFD03.1-480-016	016	1.00	R911286918
HCS01-W0054	500 / 501 / 502	4.6	NFD03.1-480-030	030	1.67	R911286919
HCS03-W0100	700 / 701 / 702	8.0	NFD03.1-480-055	055	2.21	R911286920
CtrlX Drive XCS2-W0023A	2100 / 2130	3.0	NFD03.1-480-016	016	1.00	R911286918
	2160 / 2161					
CtrlX Drive XCS2-W0054A	3100 / 3130	6.3	NFD03.1-480-030	030	1.67	R911286919
	3160 / 3161					
CtrlX Drive XCS2-W0070A	4100 / 4130	6.3	NFD03.1-480-055	055	2.21	R911286920
CtrlX Drive XCS2-W0100A	5100 / 5130	18.1	NFD03.1-480-055	055	2.21	R911286920

Mains filter option			
Assembly			R039949992
Option		Material number	Type
000		Without mains filter	
001		Only CMS: with mains filter	
007		R911286917	NFD03.1-480-007 = 7 A
016		R911286918	NFD03.1-480-016 = 16 A
030		R911286919	NFD03.1-480-030 = 30 A
055		R911286920	NFD03.1-480-055 = 55 A

► Further information on the controller ► Chapter "Further information"

Switching system MKK, MKR, MLR

Overview of switching system

1. Socket and connector
2. Mechanical switch with attachments
3. Proximity sensor
4. Switching cam
5. Cable duct / cable channel
6. Assembly magnetic sensor with connector and sensor mount
 - 6a: Magnetic sensor
 - 6b: Sensor mount incl. set screws (loose) and square nut
 - 6c: Cable holder (3 pcs) incl. set screw (loose)
 - 6d: Male connector M8x1, 3-pin
7. Magnetic sensor with M8x1 connector
8. Clamping screw
9. Sliding block

Switch mounting arrangement MKK/MKR-040-NN-3

Magnetic sensor with M8x1 connector, switch mounting plate and cable holder

The switch activator is a magnet (on both sides) that is integrated in the carriage (no switching cam necessary). The switch activation points can be positioned anywhere along the stroke. For the position of the solenoid switch, see the linear module instructions R320103169.

Instruction for mounting:

The magnetic sensor is inserted into the corresponding slot of the sensor mount and fixed by turning the clamping screw in the sensor mount.

Sensors may only be mounted on one side (left or right) of the linear module and should not be installed until the linear module has been screwed down on its mounting base. For a description of the mounting procedure and determination of the switch activation points, see the mounting instructions for linear modules.

See the chapter "Attachments and accessories" for technical data.

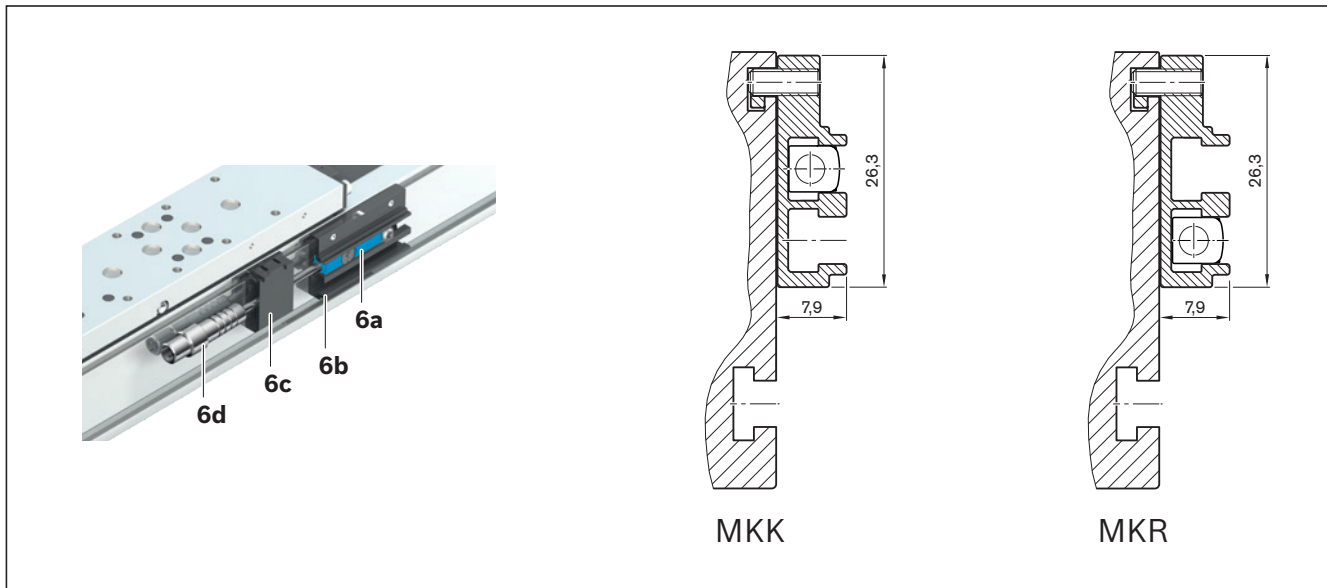

Position	Switching function	Material number	Option number	Position	Material number
6	PNP/NC	R117500140	(130)	6a	R913037445
6	NPN/NC	R117500141	(131)	6a	R913037443
6	PNP/NO	R117500142	(132)	6a	R913037444
6	NPN/NO	R117500143	(133)	6a	R913037446
				6b	R037530021
				6c	R037530022

Further switch mounting options (MKK/MKR-040-NN-3)

Proximity sensors and mechanical switches

Instruction for mounting:

The mechanical switches, the proximity sensors and the socket with connector and cable duct are fastened with attachments in T-slots of the frame. Switch activation is carried out by a switching cam on the carriage.

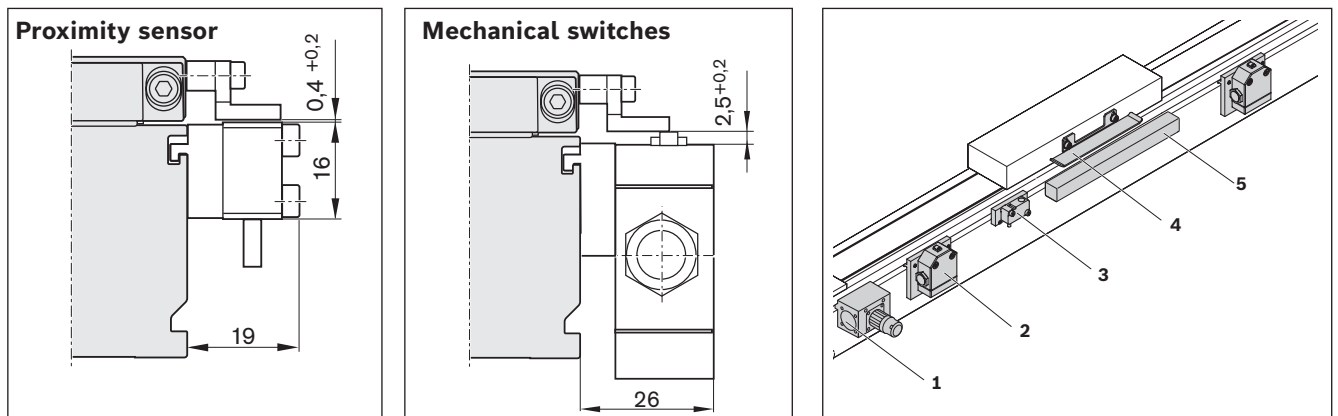

For further dimensions, see the chapter "Inductive sensors, mechanical switches and accessories" on the following pages

Position	Designation	Material number
1	Socket - plug	R117560102
2	Mechanical switch	See the chapter on sensors and accessories
	Mechanical switch with attachments	R039980087
3	Proximity sensor	See the chapter on sensors and accessories
	Attachments without sensor	R117560103
	Proximity sensor with attachments	R039980088 (PNP - NC) R039980095 (PNP - NO)
4	Switching cam	R039980104
5	Cable duct	R039662018

These switching versions can only be ordered with these material numbers

Switching system MKK, MKR, MLR

Switch mounting arrangement MKK/MKR -065/-080/-110/-140-NN-3

Magnetic sensor with M8x1 connector

The switch activator is a magnet (on both sides) that is integrated in the carriage (no switching cam necessary). The switch activation points can be positioned anywhere along the stroke. For the position of the solenoid switch, see the linear module instructions R320103169.

Instruction for mounting:

The magnetic sensor is positioned in the corresponding sensor slot (S) and fixed by turning the clamping screw (8). The sliding block (9) is not necessarily required for mounting, it is only required for repeatable mounting of the sensor.

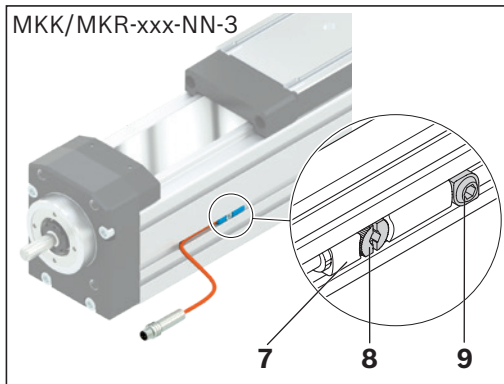

Position	Switching function	Material number	Option number
7	PNP/NC	R913037445	(120)
7	NPN/NC	R913037443	(121)
7	PNP/NO	R913037444	(122)
7	NPN/NO	R913037446	(123)
9	Sliding block	R117509008	---

For further sensors/switches, see the chapter "Inductive sensors, mechanical switches and accessories" on the following pages

Switch mounting arrangement MLR-080/-110-NN-3

Magnetic sensor with M8x1 connector

The switch activator is a magnet (on both sides) that is integrated in the carriage (no switching cam necessary). The switch activation points can be positioned anywhere along the stroke. For the position of the solenoid switch, see the linear module instructions R320103169.

Instruction for mounting:

Insert sensor mount (a) into the sensor slot (S), carry out rough positioning and fix in place with two set screws (b). Then, install the magnetic sensor (7) in the sensor mount and fix it in place by turning the clamping screw (8).

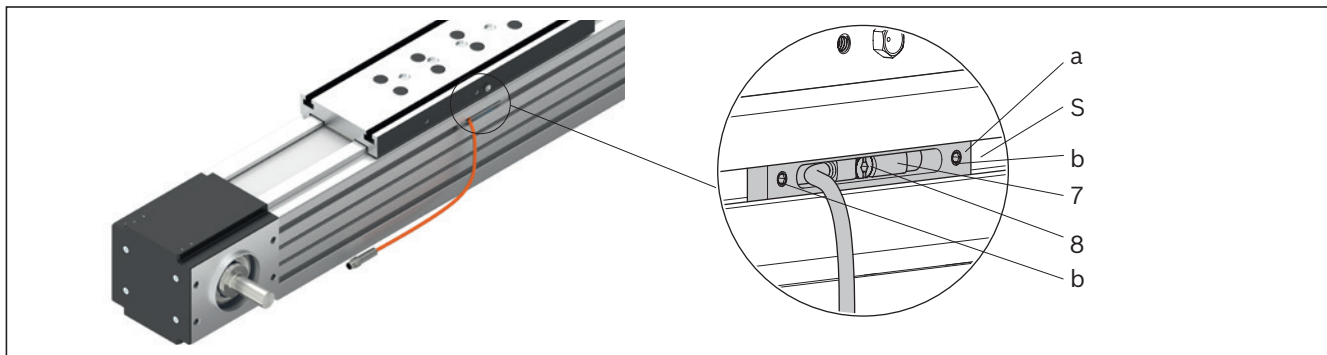

Position	Switching function	MLR-080-NN-3		MLR-110-NN-3	
		Material number Assembly with sensor	Option number	Material number Assembly with sensor	Option number
7 + a	PNP/NC	R039980210	(140)	R039980214	(144)
7 + a	NPN/NC	R039980211	(141)	R039980215	(145)
7 + a	PNP/NO	R039980212	(142)	R039980216	(146)
7 + a	NPN/NO	R039980213	(143)	R039980217	(147)

Assembly magnetic sensor with connector includes magnetic sensor, sensor mount including set screws (loose).

For further sensors/switches, see the chapter "Inductive sensors, mechanical switches and accessories" on the following pages

Switch mounting arrangement MKR-145-NN-3

Magnetic sensor with M8x1 connector

The switch activator is a magnet (on both sides) that is integrated in the carriage (no switching cam necessary). The switch activation points can be positioned anywhere along the stroke. For the position of the solenoid switch, see the linear module instructions R320103169.

Instruction for mounting:

Insert sensor mount (a) into the sensor slot (S), carry out rough positioning and fix in place with two set screws (b). Then, install the magnetic sensor (7) in the sensor mount and fix it in place by turning the clamping screw (8).

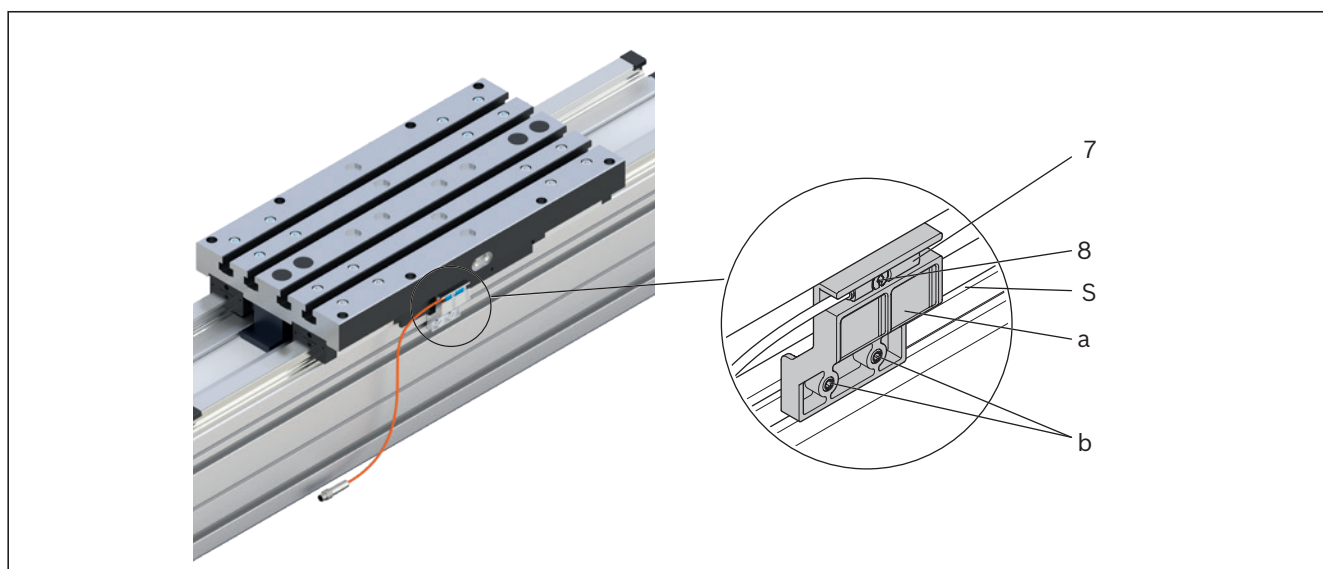

Item	Switching function	Material number	Option number
		Assembly with sensor	
7 + a	PNP/NC	R039980140	(125)
7 + a	NPN/NC	R039980142	(126)
7 + a	PNP/NO	R039980141	(127)
7 + a	NPN/NO	R039980143	(128)

Assembly magnetic sensor with connector includes magnetic sensor, sensor mount including set screws (loose).

For further sensors/switches, see the chapter "Inductive sensors, mechanical switches and accessories" on the following pages

Switching system MKK, MKR, MLR

Inductive sensors, mechanical switches and accessories (MKK/MKR/MLR)

Instruction for mounting:

The mechanical switches, the proximity sensors and the socket with connector and cable duct are fastened with attachments in T-slots of the frame. Switch activation is carried out by a switching cam on the carriage.

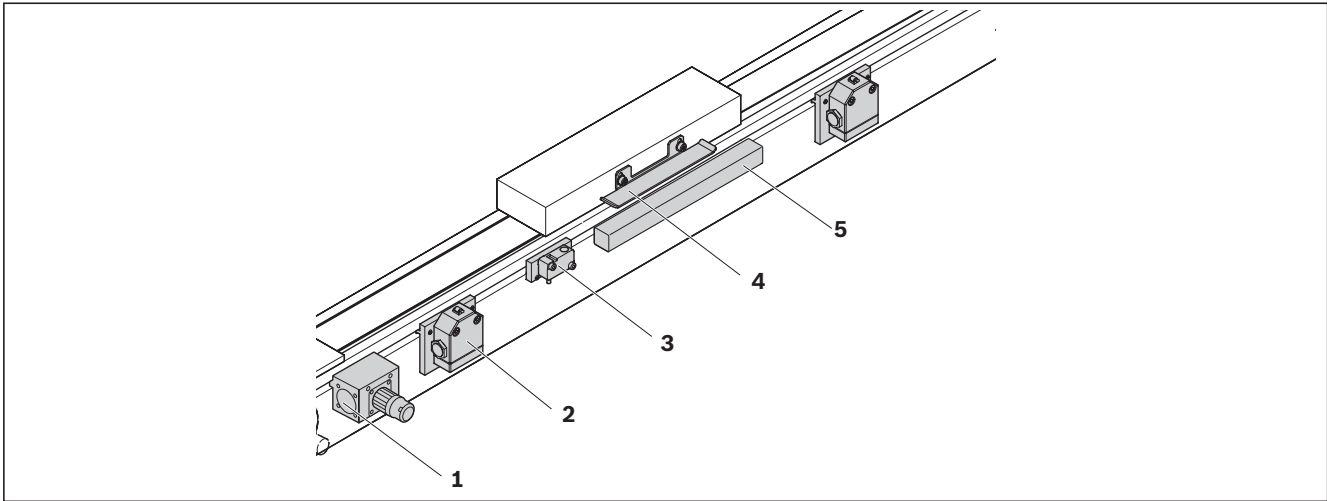

Item	Designation	Material number		
		Sizes -065 / -080 / -140 /-145-NN-3	-110-NN-3	-165-NN-2
1	Socket-plug	R117500153		
2	Mechanical switch	See the chapter on sensors and accessories		
	Mech. switches with attachments	R117500151 (incl. switches R345304016)		
	Attachments without mech. Switches	R117500165		
3	Proximity sensor	See the chapter on sensors and accessories		
	Attachments without sensor	R117500152	R117520152	R117500152
	Proximity sensor with attachments	R039980001 (PNP - NC)	R039980010 (PNP - NC)	R039980001 (PNP - NC)
		R039980002 (NPN - NC)	R039980011 (NPN - NC)	R039980002 (NPN - NC)
		R039980003 (PNP - NO)	R039980012 (PNP - NO)	R039980003 (PNP - NO)
R039980004 (NPN - NO)		R039980013 (NPN - NO)	R039980004 (NPN - NO)	
4	Switching cam	R117500149		R117500150
5	Cable duct	R039662017		

These switching versions can only be ordered with these material numbers

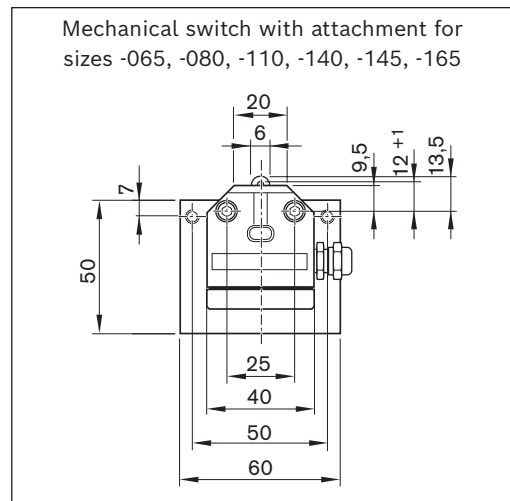
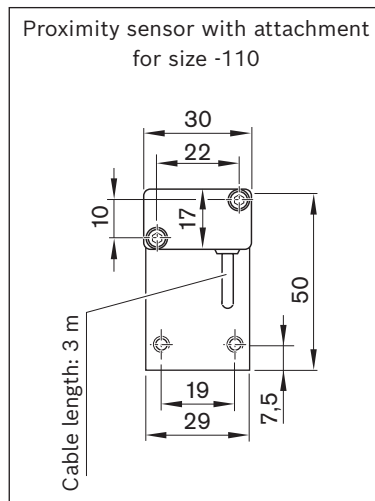
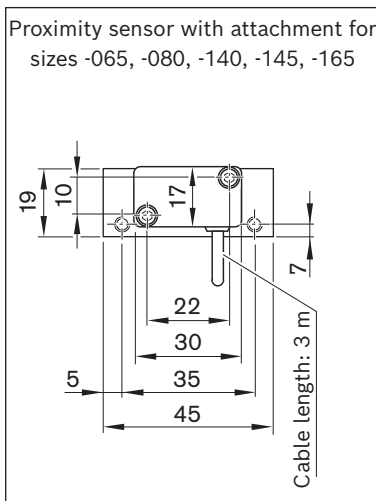

Cable duct

The cable duct is fastened in the lateral slots of the frame. Fastening screws widen the profile and ensure that the cable duct is securely mounted. The cable duct will accommodate up to two cables for mechanical switches and three cables for proximity switches. Fastening screws and cable grommets are included.

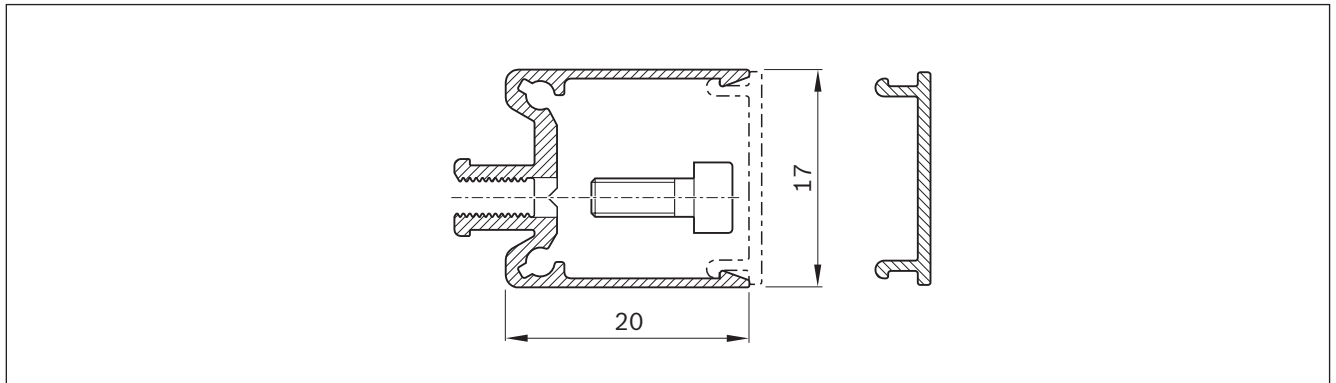

Mounting examples of switches

Determining the switch activation points

Switching distance: The switching distance is the distance between the carriage center (TM) and the zero point (0) when a switch is activated (given in mm). Example for a mechanical limit switch (provided the zero point is at L/2):

Maximum switching distance = $0.5 \times (\text{max. travel range}) - \text{excess travel} = 0.5 \times \text{effective stroke}$

For safe operation of the linear module, the excess travel must be longer than the braking distance.

For MKR... and MLR...: The acceleration travel s_a can be taken as a guideline value for the braking distance.

For MKK...: In most cases the guideline value for excess travel (braking path) is: $\text{Excess travel} = 2 \times \text{screw lead } P$.

Take note of the minimum switching distance (determined by the attachments):

mechanical-mechanical = 60 mm; mechanical-proximity = 45 mm; proximity-proximity = 28 mm.

for MKR-145: mechanical-mechanical = 62 mm; mechanical-proximity = 49 mm; proximity-proximity = 35 mm

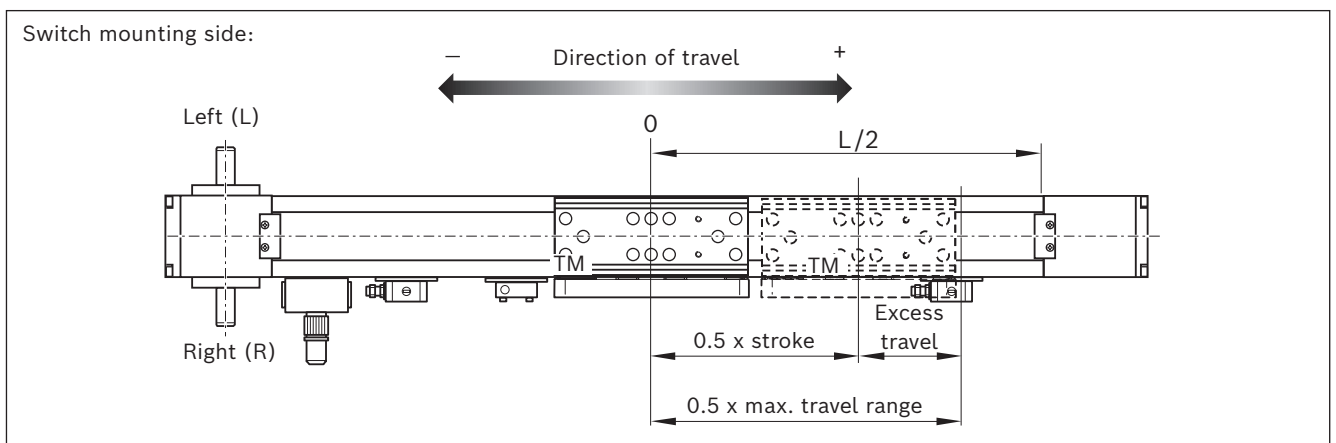

Switching system MKK, MKR, MLR

Switch mounting

MKK/MKR-065/-080/-110/-140-NN-3; MKK/MKR-165-NN-2

Magnetic sensor, mechanical switch / proximity sensors

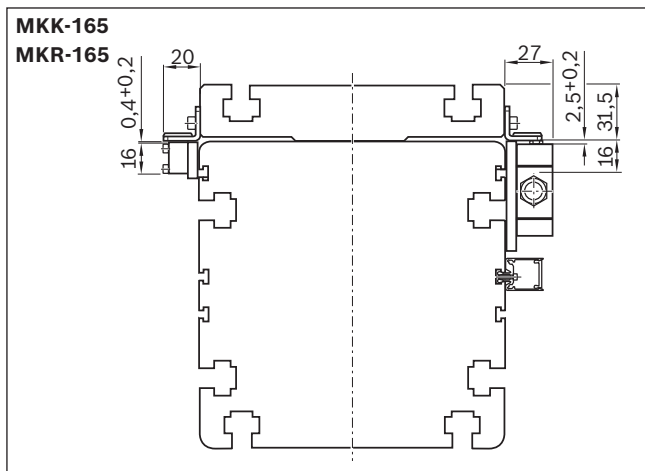
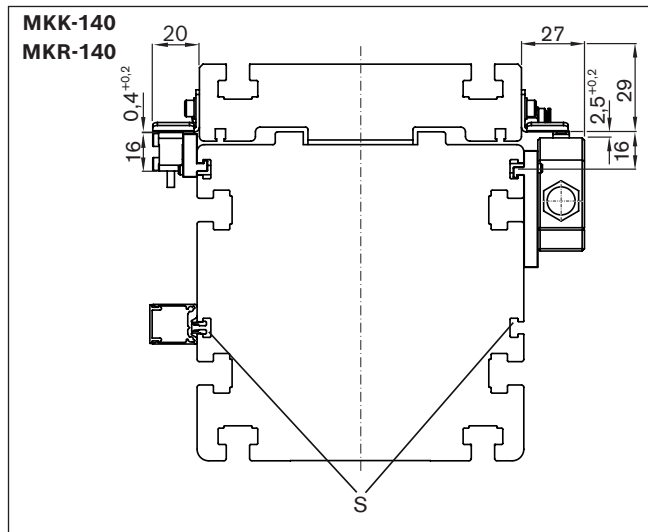
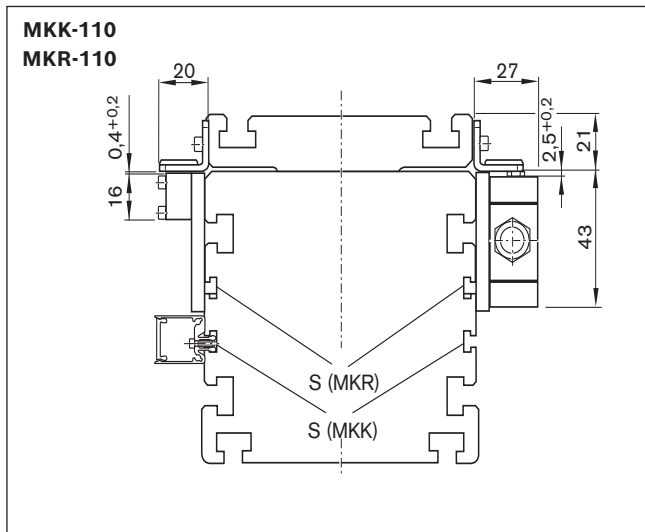
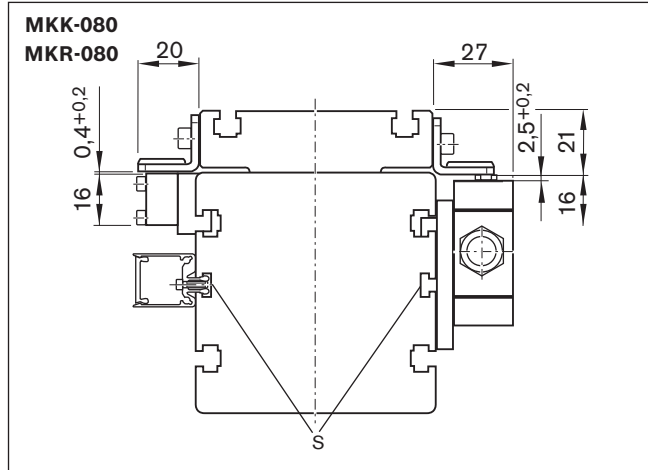
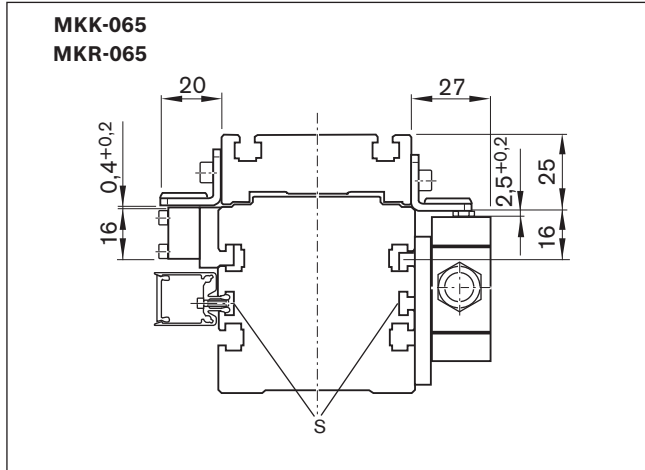

S = Sensor slot for magnetic sensor MKK/MKR-xxx-NN-3

MLR-080 / -110-NN-3

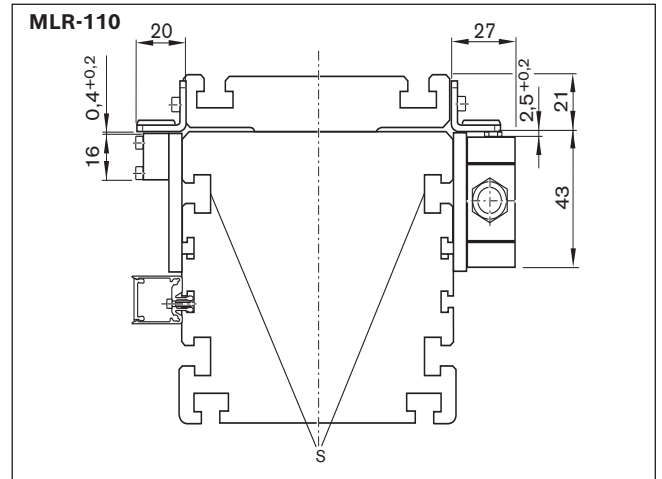
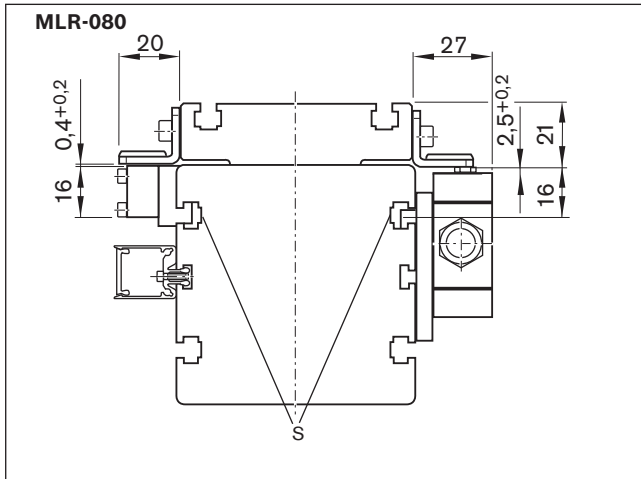

S = Slot for sensor mount MLR-xxx-NN-3

MKR-145-NN-3

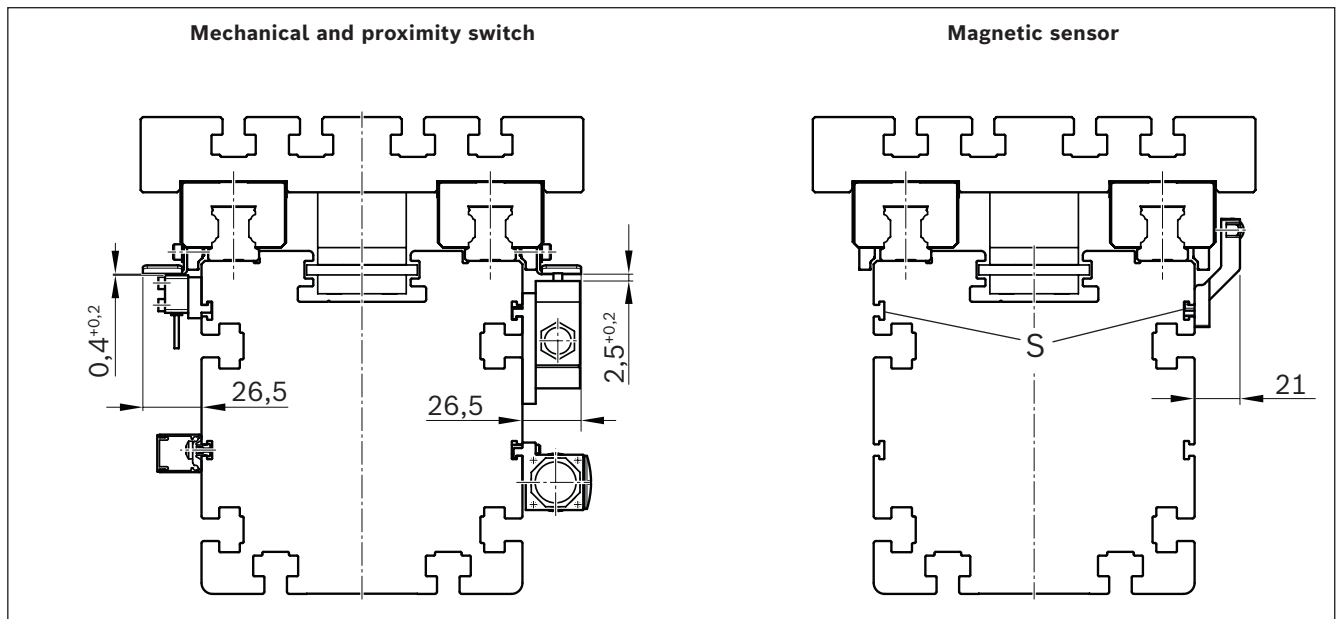

S = Slot for sensor mount MKR-145-NN-3

Switching system MKK, MKR, MLR

Socket and connector, cable duct

Attach the socket to the side with the most switches. Socket and connector are not pre-wired. The variable sliding attachment allows switch activation points to be optimized during commissioning. The connector can be mounted in three directions.

R117560102

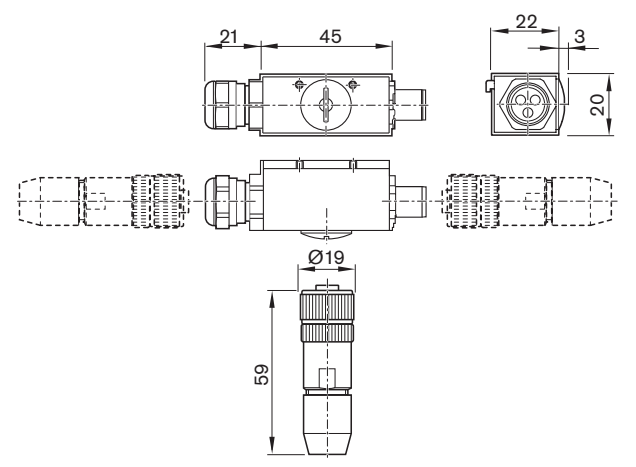
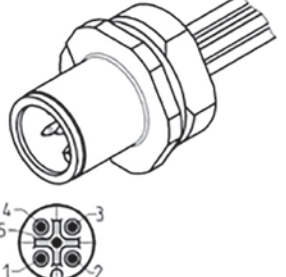

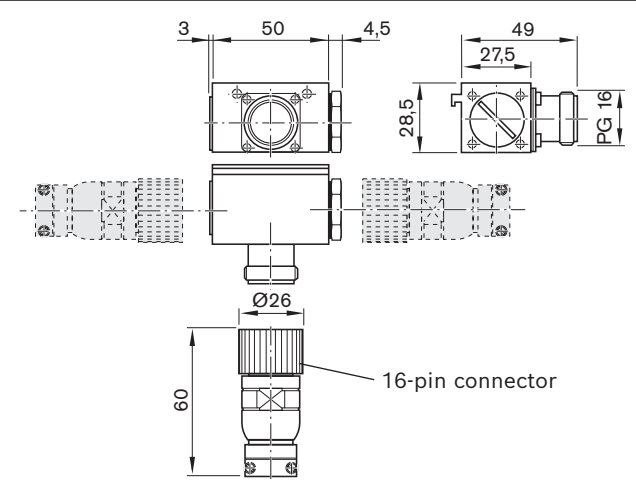
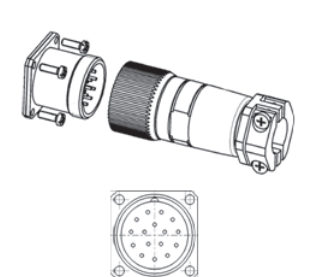

Pin		Color
1	BN	brown
2	WH	white
3	BU	blue
4	BK	black
5	GY	gray

R037540000

R117500153

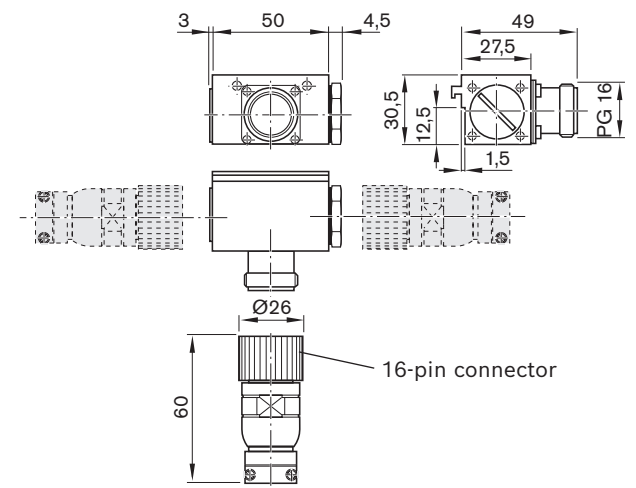
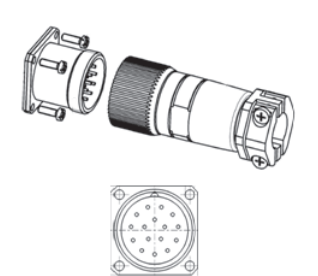
Use	Socket and connector		
Material number	R117560102	R037540000	R117500153
Designation	for MKK / MKR -040	for MKK / MKR -040	for MKx -065/-080/-110/-145/-165 for MLR-080/-110
Version	angled, for suspension in the lateral slot of the linear motion system		
Operating current per contact	max. 4 A	max. 8 A	
Operating voltage	10–30 V DC	150 V AC/DC	
Connection type 1	Male connector, straight, M12x1, 5-pin, spring-cage connection	Male connector, straight, 16-pin, soldered connection	
Connection type 2	Coupling / flange socket M12x1, 5-pin, with 0.5 m cable	Coupling / flange socket, 16-pin, soldered connection	
Housing cable bushing	Cable gland M16x1.5 with seal (bore 3x3.5 mm) incl. cap and blind plug	1 seal with bore 2x5.5 mm, 1x3.5 mm 1 adaptable seal, max. 14 mm diameter incl. cap and dummy plug	
Cable bushing, connector	Bolting with pull relief		
Connection cross-section	0.14 ... 0.5 mm	0.14 ... 1 mm	
Cable diameter	4 ... 8 mm	10 ... 14 mm	
Ambient temperature	-25 °C to +85 °C	-20 °C to +125 °C	
Protection class	–		
Certifications and approvals	–		

Sensors



Magnetic sensor with M8x1 connector

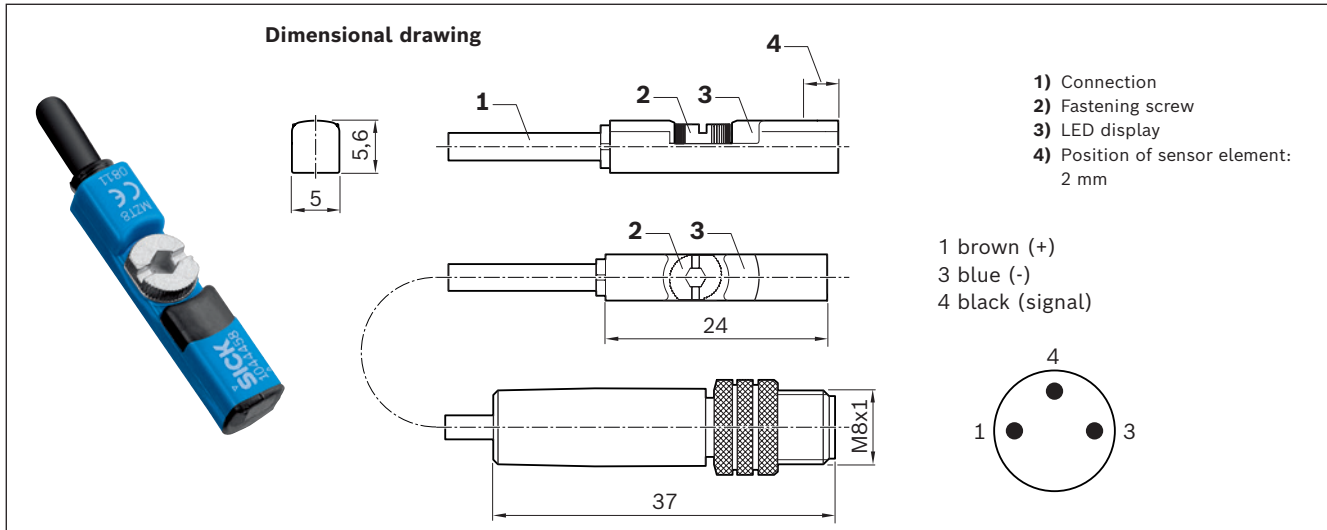

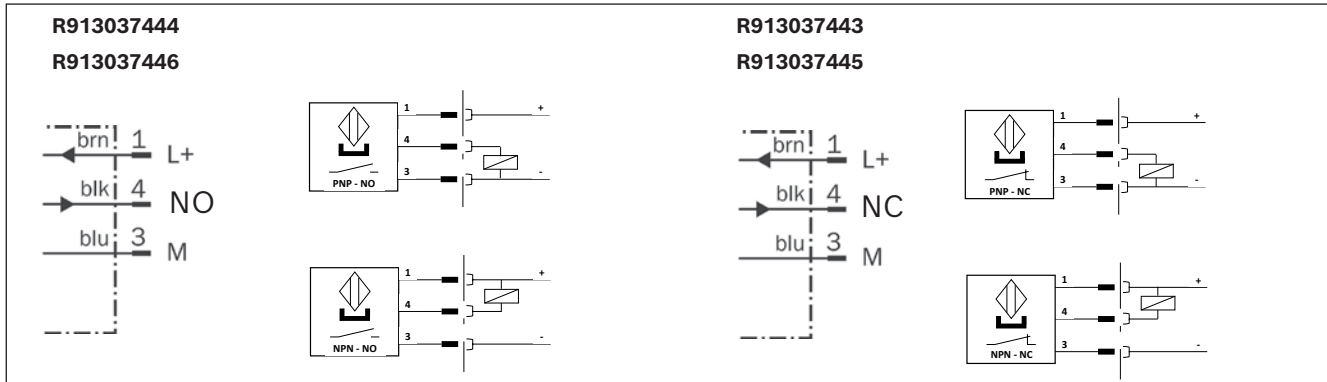
Connection diagram



Material numbers/technical data

Use	Limit switch	Reference switch	Limit switch	Reference switch
Material number	R913037445	R913037444	R913037443	R913037446
Designation	MZT8-03VPO-KRDS14	MZT8-03VPS-KRDS13	MZT8-03VNO-KRDS16	MZT8-03VNS-KRDS15
Functional principle	magnetic			
Operating voltage	10 - 30 VDC			
Load current	≤ 200 mA			
Switching function	PNP/NC	PNP/NO	NPN/NC	NPN/NO
Connection type	0.5 m cable and M8x1 plug, 3-pin with knurled screw connection			
Function indicator	✓			
Short-circuit protection	✓			
Reverse polarity protection	✓			
Switch-on suppression	✓			
Switching frequency	3 kHz			
Pulse elongation (off delay)	20 ms			
Max. permissible starting speed	5 m/s			
Suitable for drag chains*	✓			
Torsion-resistant*	✓			
Welding spark-resistant*	—			
Cable cross-section*	3x0.14 mm ²			
Cable diameter D*	2.9 ±0.15 mm			
Static bending radius*	≥ 5xD			
Dynamic bending radius*	≥ 10xD			
Bending cycles*	> 2 Mio.			
Max. permissible travel speed*	5 m/s			
Max. permissible acceleration*	≤ 5 m/s ²			
Ambient temperature	-30°C bis +80°C			
Protection class	IP68			
MTTFd (per EN ISO 13849-1)	MTTFd = 2339.0 years			
Certifications and approvals**	  			



*) Technical data only for the cast-on connection line (0.5 m) on the magnetic sensor. Available extension cables offer even more performance, e.g. for use in a cable drag chain (see below).

**) No  certificate for import to the Chinese market required for these products. Document "Sales information CCC" available on request.

Sensors

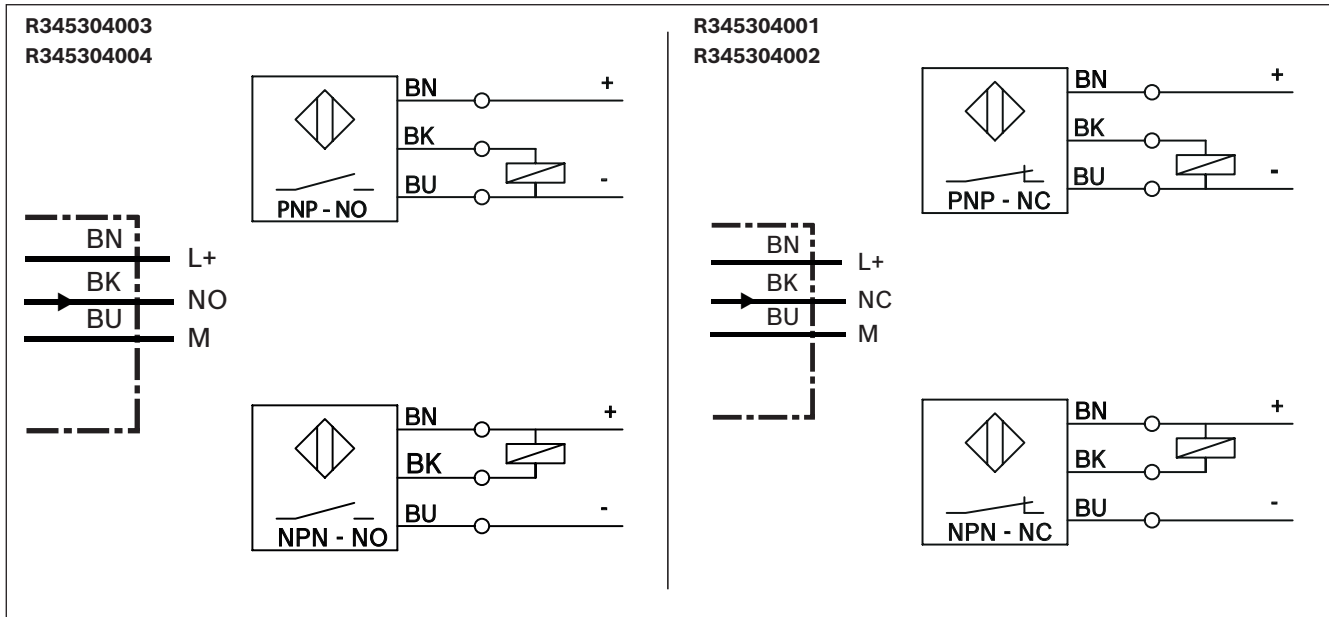
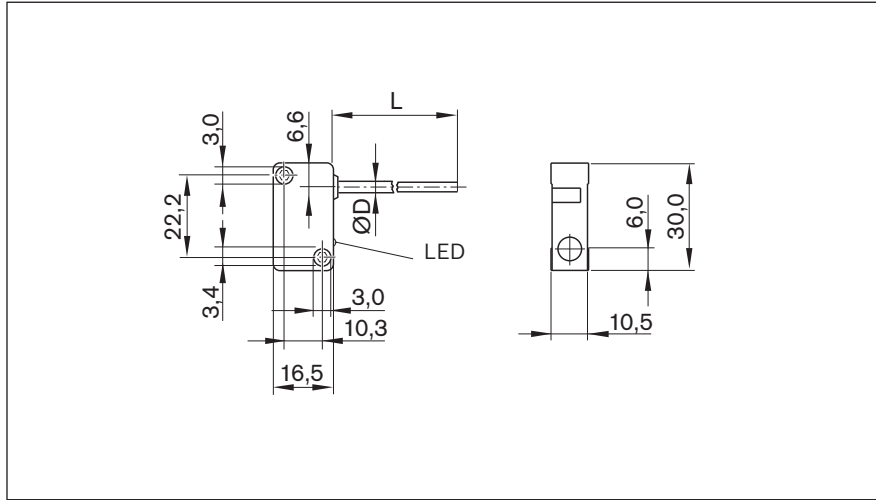
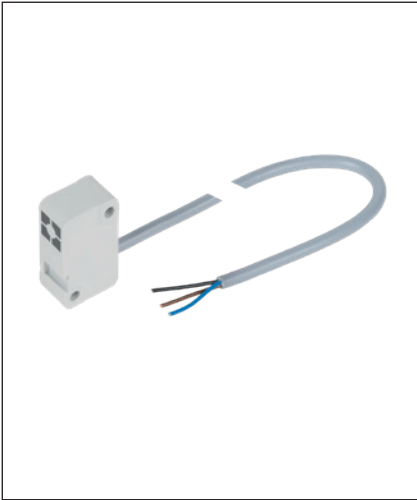
Inductive sensor with free line end



Material numbers/technical data				
Use	Limit switch	Reference switch	Limit switch	Reference switch
Material number	R345304001	R345304003	R345304002	R345304004
Designation	BES 517-351-NO-C-03	BES 517-398-NO-C-03	BES 517-352-NO-C-03	BES 517-399-NO-C-03
Functional principle	inductive			
Operating voltage	10–30 V DC			
Load current	≤ 200 mA			
Switching function	PNP/NC	PNP/NO	NPN/NC	NPN/NO
Connection type	Line 3 m, 3-pin, free line end			
Function indicator	✓			
Short-circuit protection	✓			
Reverse polarity protection	✓			
Switching frequency	2.5 kHz			
Max. permissible starting speed	depending on the length of the switching cam			
Suitable for drag chains*	–			
Torsion-resistant*	–			
Welding spark-resistant*	–			
Cable cross-section*	3x0.14 mm ²			
Cable diameter D*	3.5 ±0.15 mm			
Static bending radius*	12 mm			
Dynamic bending radius*	12 mm			
Bending cycles*	–			
Ambient temperature	-40°C to +70°C			
Protection class	IP65			
MTTFd (acc. to EN ISO 13849-1)	MTTFd = 830 years		MTTFd = 585 years	
Certifications and approvals**	  			

*) Technical data only for the cast-on connection line at the proximity sensor.

The available extension cables offer even better performance, e.g. when using a cable drag chain (see following pages).



***) No  certificate is required to introduce these products to the Chinese market.

Sensors

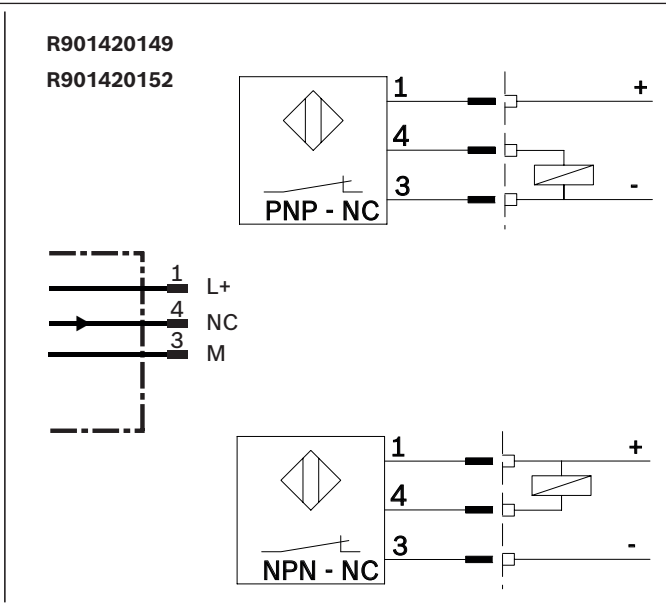
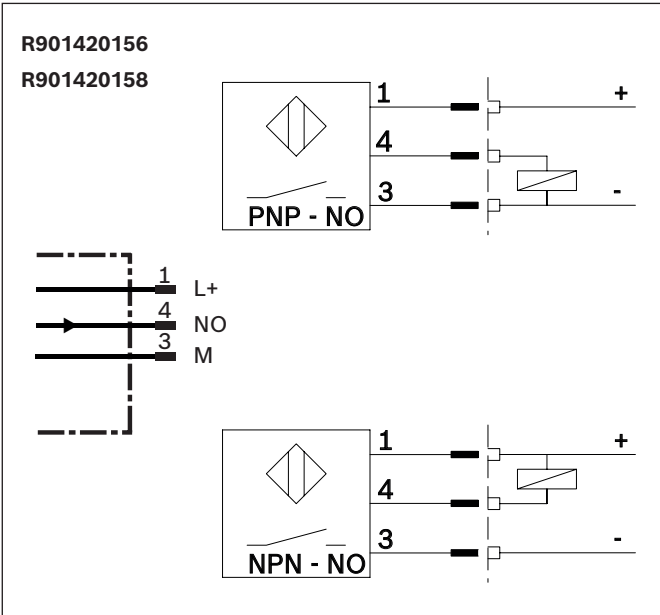
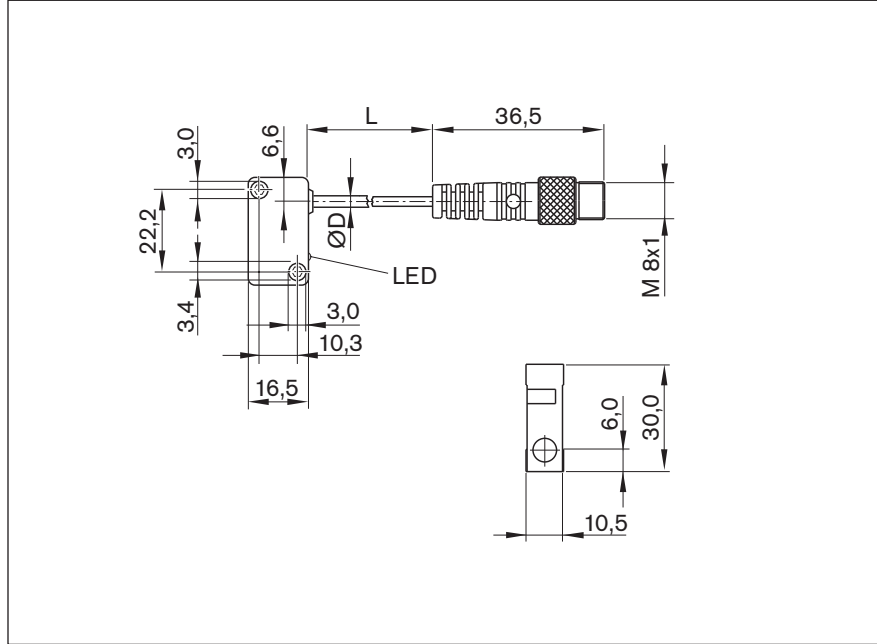
Inductive sensor with M8x1 connector



Material numbers/technical data

Use	Limit switch	Reference switch	Limit switch	Reference switch
Material number	R901420149	R901420156	R901420152	R901420158
Designation	BES 517-351-NO-C-S49-00.2	BES 517-398-NO-C-S49-00.2	BES 517-352-NO-C-S49-00.2	BES 517-399-NO-C-S49-00.2
Functional principle	inductive			
Operating voltage	10–30 V DC			
Load current	≤ 200 mA			
Switching function	PNP/NC	PNP/NO	NPN/NC	NPN/NO
Connection type	Cable 0.2 m and connector M8 x 1, 3-pin with knurled screw			
Function indicator	✓			
Short-circuit protection	✓			
Reverse polarity protection	✓			
Switching frequency	2.5 kHz			
Max. permissible starting speed	depending on the length of the switching cam			
Suitable for drag chains*	–			
Torsion-resistant*	–			
Welding spark-resistant*	–			
Cable cross-section*	3x0.14 mm ²			
Cable diameter D*	3.5 ±0.15 mm			
Static bending radius*	12 mm			
Dynamic bending radius*	12 mm			
Bending cycles*	–			
Ambient temperature	-40°C to +70°C			
Protection class	IP65			
MTTFd (per EN ISO 13849-1)	MTTFd = 830 years		MTTFd = 585 years	
Certifications and approvals**	  			

*) Technical data only for the cast-on connection line at the proximity sensor.

The available extension cables offer even better performance, e.g. when using a cable drag chain (see following pages).





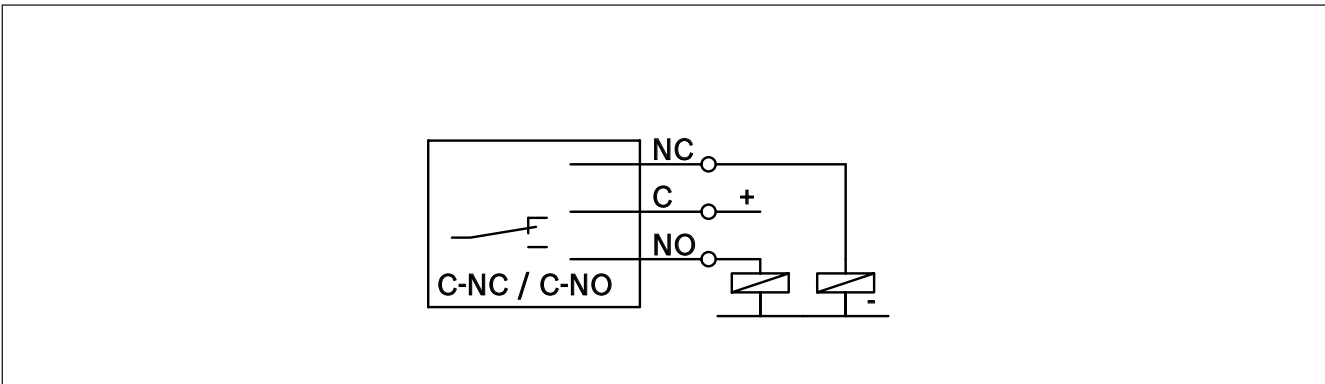
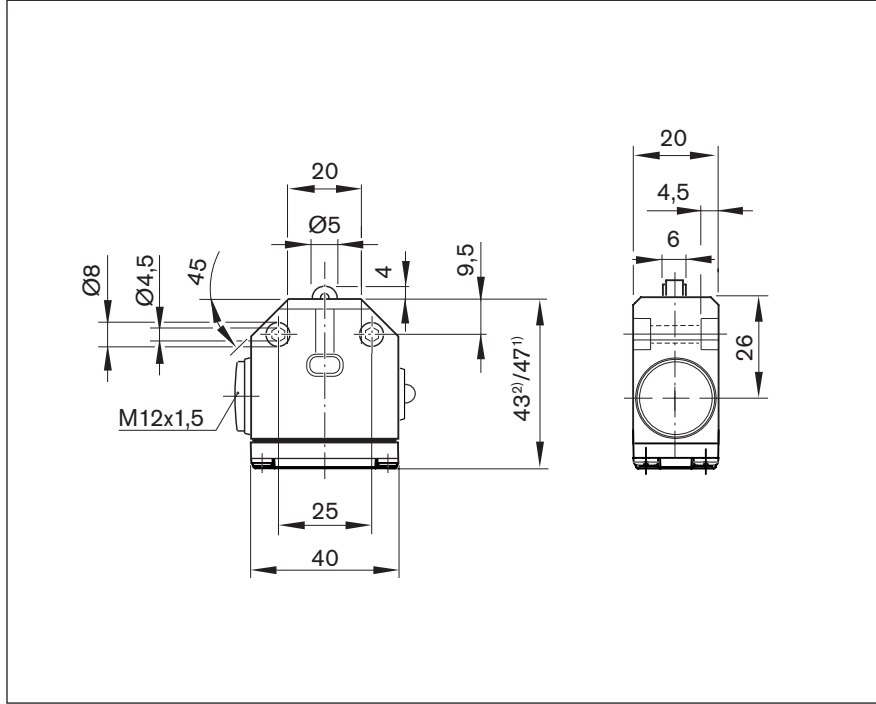

**) No  certificate is required to introduce these products to the Chinese market.

Switches

Mechanical switch



Material numbers/technical data



Use	Limit switch	
Material number	R345304016 ¹⁾	R347600305 ²⁾
Designation	BNS 819-X496-99-R-11	BNS 819-X510-99-R-10
Functional principle	mechanical, roller	
Operating voltage	250 V AC	
Load current	≤ 5 A	
Switching function	single-pole changeover / (NC: C+NC, NO: C+NO)	
Connection type	Screw connection, without line	
Function indicator	-	
Switching frequency	3.3 Hz	
Max. permissible starting speed	1 m/s	
Ambient temperature	-5 °C to +85 °C	
Protection class	IP67	
B10d value	5x10 ⁶ (wet area); 10x10 ⁶ (dependent on current load (dry area))	
Certifications and approvals, housing	  	
Certifications and approvals, switching element	   	

Switches

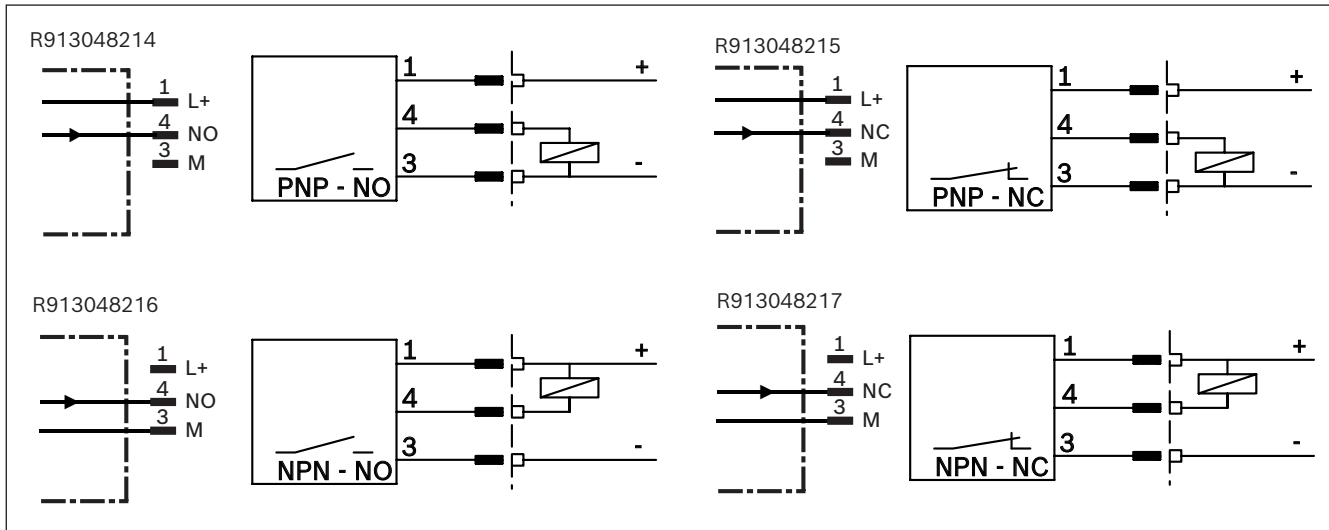
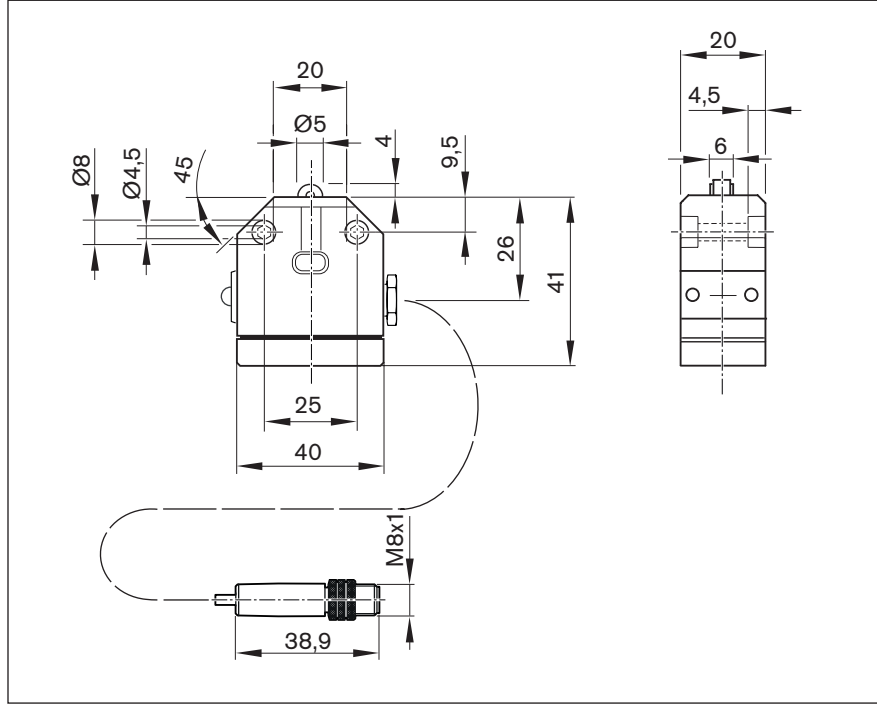
Mechanical switch with M8x1 connector



Material numbers/technical data

Use	Limit switch	Reference switch	Limit switch	Reference switch
Material number	R913048215	R913048214	R913048217	R913048216
Designation	BNS 819-X1002-99-R-10	BNS 819-X1001-99-R-10	BNS 819-X1004-99-R-10	BNS 819-X1003-99-R-10
Functional principle	mechanical, roller			
Operating voltage	10 - 30 VDC			
Load current	≤ 200 mA			
Switching function	PNP/NC	PNP/NO	NPN/NC	NPN/NO
Connection type	Cable 0.2 m and connector M8 x 1, 3-pin with knurled screw			
Function indicator	-			
Short-circuit protection	-			
Reverse polarity protection	-			
Switching frequency	3.3 Hz			
Max. permissible starting speed	1 m/s			
Suitable for drag chains¹⁾	-			
Torsion-resistant¹⁾	-			
Weld spark-resistant¹⁾	-			
Cable cross-section¹⁾	3x0.14 mm ²			
Cable diameter D¹⁾	4.3 ±0.2 mm			
Static bending radius¹⁾	12 mm			
Dynamic bending radius¹⁾	12 mm			
Bending cycles¹⁾	-			
Ambient temperature	-5 °C to +70 °C			
Protection class	IP65			
B10d value	5x10 ⁶ (wet area); 10x10 ⁶ (dependent on current load (dry area))			
Certifications and approvals²⁾	  			

¹⁾ Technical data only for the cast-on connection line at the mechanical switch.

The available extension cables offer even better performance, e.g. when using a cable drag chain (see following pages).

²⁾ No  certificate is required to introduce these products to the Chinese market.

Extensions

Assembled on one end

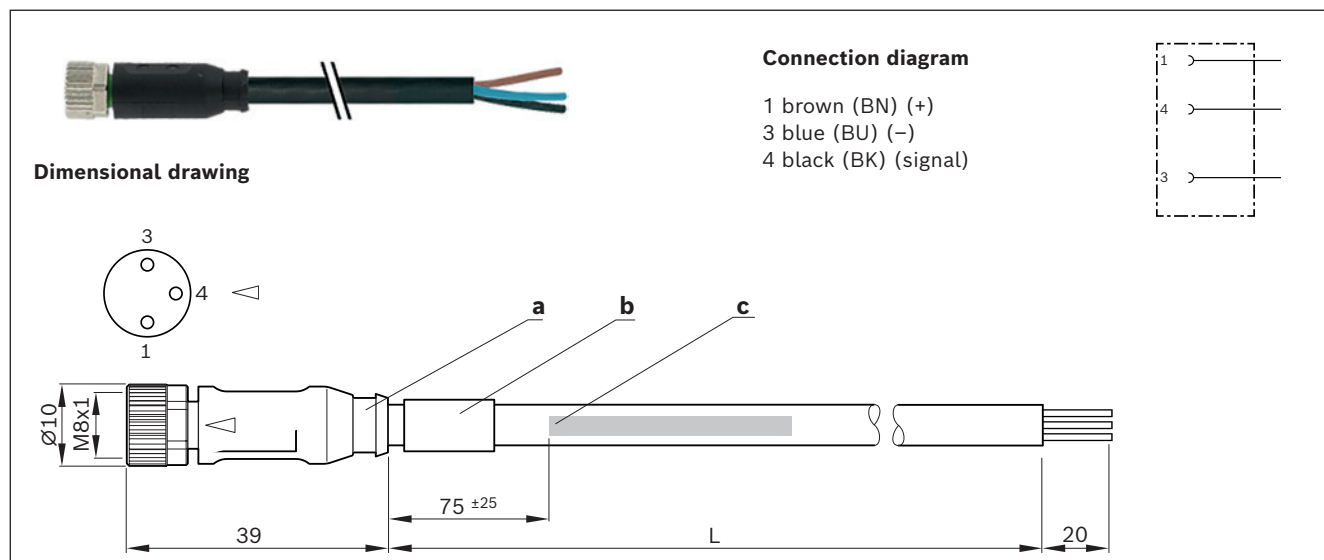

Material numbers

Use	Extension cable		
Material number	R911344602	R911344619	R911344620
Designation	7000-08041-6500500	7000-08041-6501000	7000-08041-6501500
Length (L)	5.0 m	10.0 m	15.0 m
Connection type 1	Female connector, straight, M8x1, 3-pin		
Connection type 2	Unassembled cable end		

- a) Contour for 6.5 mm corrugated tube (inner diameter)
- b) Cable grommet
- c) Cable printing per printing specification



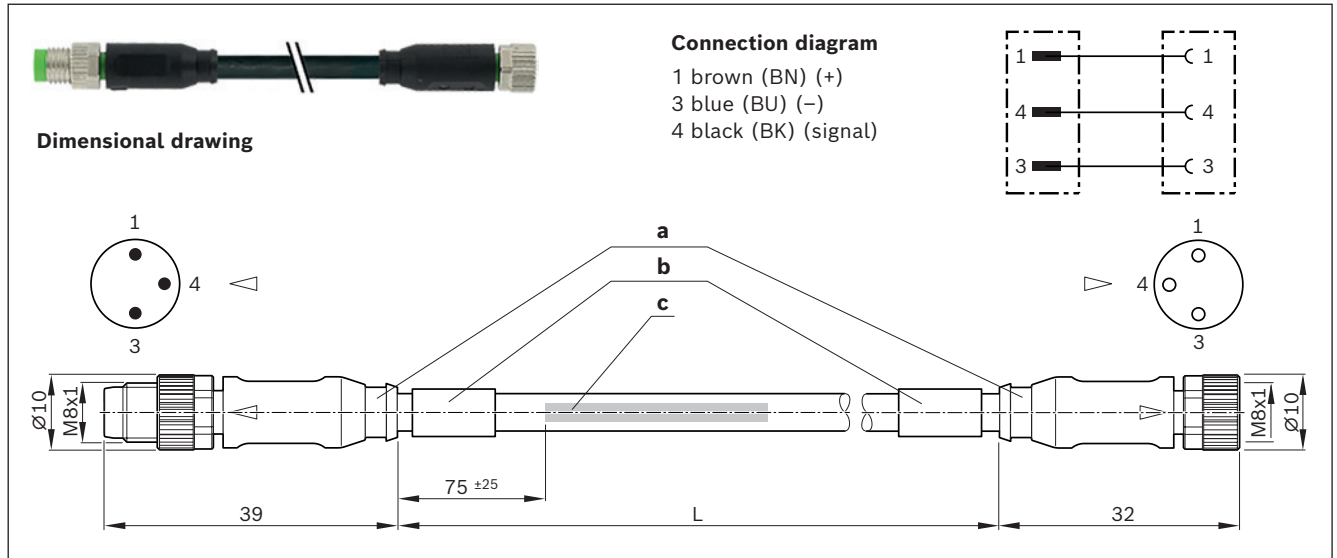

Assembled on two sides



Material numbers



Use	Extension cable				
Material number	R911344621	R911344622	R911344623	R911344624	R911344625
Designation	7000-88001-6500050	7000-88001-6500100	7000-88001-6500200	7000-88001-6500500	7000-88001-6501000
Length (L)	0.5 m	1.0 m	2.0 m	5.0 m	10.0 m
Connection type 1	Female connector, straight, M8x1, 3-pin				
Connection type 2	Connector, straight, M8x1, 3-pin				

Technical data for extensions pre-assembled on one or two sides

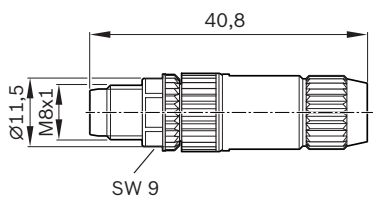
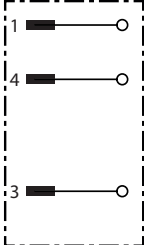
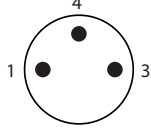

Function indicator	-
Operating voltage indicator	-
Operating voltage	10–30 V DC
Type of cable	PUR black
Suitable for drag chains	✓
Torsion-resistant	✓
Weld spark-resistant	✓
Cable cross-section	3x0.25 mm ²
Cable diameter D	4.1 ± 0.2 mm
Static bending radius	≥ 5xD
Dynamic bending radius	≥ 10xD
Bending cycles	> 10 mil.
Max. permissible travel speed	3.3 m/s for 5 m travel range (typ.), up to 5 m/s for 0.9 m travel range
Max. permissible acceleration	≤ 30 m/s ²
Ambient temperature fixed ext.	-40°C to +85°C
Ambient temperature flexible ext.	-25°C to +85°C
Protection class	IP68
Certifications and approvals	    

- a) Contour for 6.5 mm corrugated tube (inner diameter)
- b) Cable grommet
- c) Cable printing per printing specification

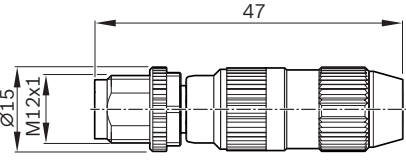
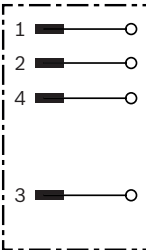
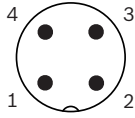
Connectors

	Dimensional drawing	Connection diagram	Connector side view
 R901388333			
 R901388352			

Material numbers/technical data

Use	Connector, single	
Material number	R901388333	R901388352
Designation	7000-08331-0000000	7000-12491-0000000
Version	straight	
Operating current per contact	max. 4 A	
Operating voltage	max. 32 V AC/DC	
Connection type	Straight connector, M8x1, 3-pin, IDC, self-locking screw	Straight connector, M12x1, 4-pin, IDC, self-locking screw
Function indicator	-	
Operating voltage indicator	-	
Connection cross-section	0.14 ... 0.34 mm ²	
Ambient temperature	-25°C to +85°C	
Protection class	IP67 (inserted and bolted)	
Certifications and approvals	  	

Adapters



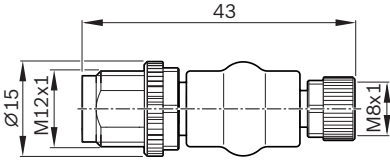

R911344591

Dimensional drawing

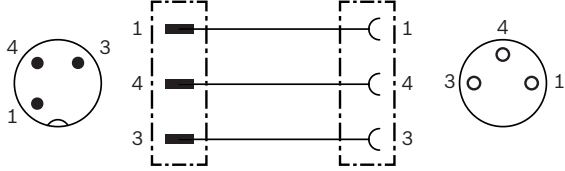

Connection diagram





R911344592



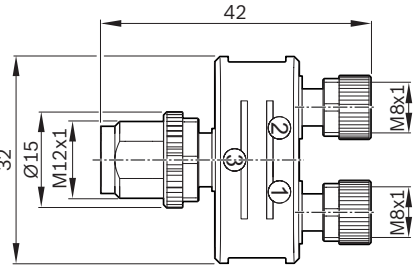

Dimensional drawing

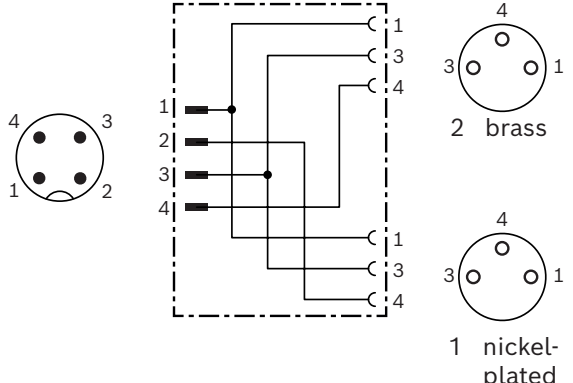

Connection diagram



Material numbers/technical data

Use	Adapters	Adapter or distributor
Material number	R911344591	R911344592
Designation	7000-42201-0000000	7000-41211-0000000
Version	straight for 1 sensor	straight, for 1 - 2 sensors
Operating current per contact	max. 4 A	
Operating voltage	max. 32 V AC/DC	
Connection type 1	Female connector, straight, M8x1, 3-pin self-locking screw thread	2 X Female connector, straight, M8x1, 3-pin self-locking screw thread
Connection type 2	Connector, straight, M12x1, 3-pin, self-locking screw thread	Connector, straight, M12x1, 4-pin self-locking screw thread
Function indicator	-	
Operating voltage indicator	-	
Connection cross-section	-	
Ambient temperature	-25°C to +85°C	
Protection class	IP67 (inserted and bolted)	
Certifications and approvals		  

Passive distributor

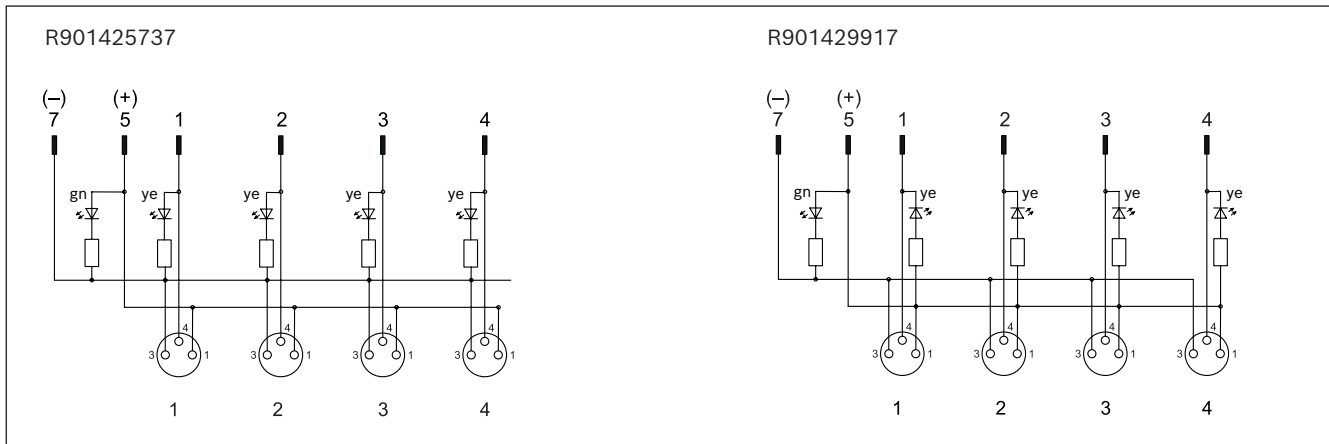
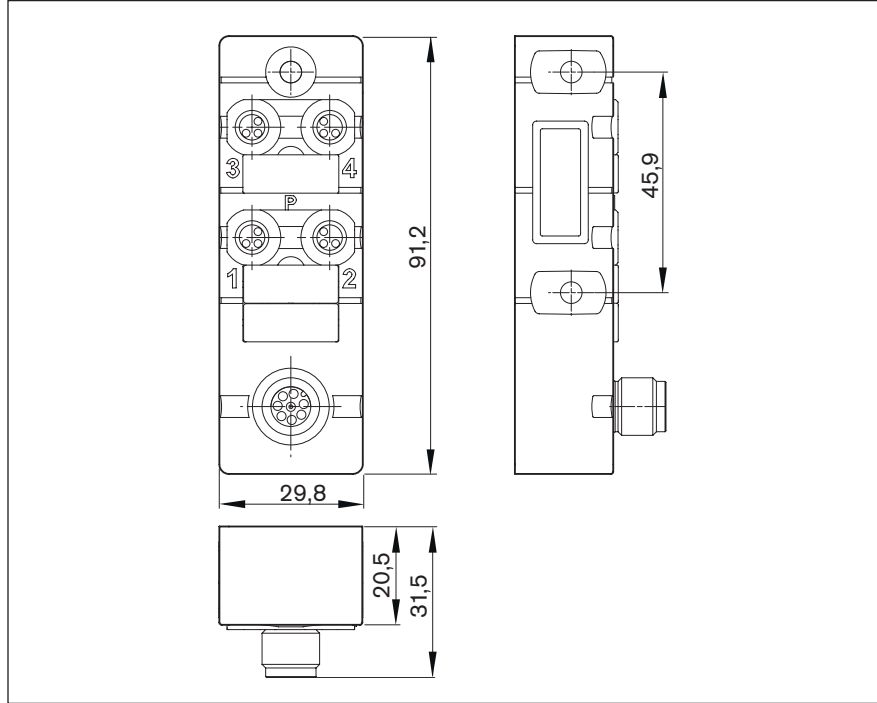

Material numbers/technical data

Use	Passive distributor		
Material number	R901425737	R901429917	R911344592
Designation	8000-84070-0000000	8000-84071-0000000	
Version	straight, for 1 - 4 sensors		
Operating current per contact	max. 2 A		
Operating voltage	24 VDC		
Switching logic	PNP	NPN	
Connection type 1	4x female connectors, straight, M8x1, 3-pin, self-locking screw thread		
Connection type 2	Male connector, straight, M12x1, 8-pin, IDC, self-locking screw thread		
Function indicator	✓		
Operating voltage indicator	✓		
Connection cross-section	-		
Ambient temperature	-20 °C bis +70 °C		
Protection class	IP67 (inserted and bolted)		
Certifications and approvals			

For technical data and dimensional drawings, see adapter

Accessories for passive distributors

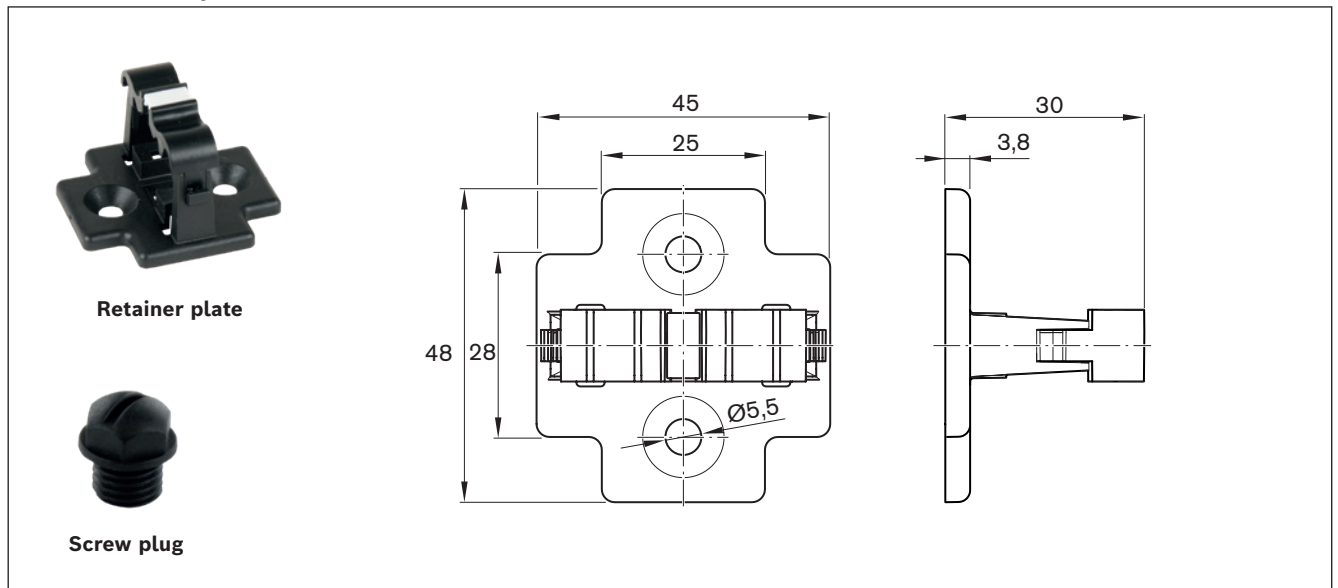

Material numbers/technical data



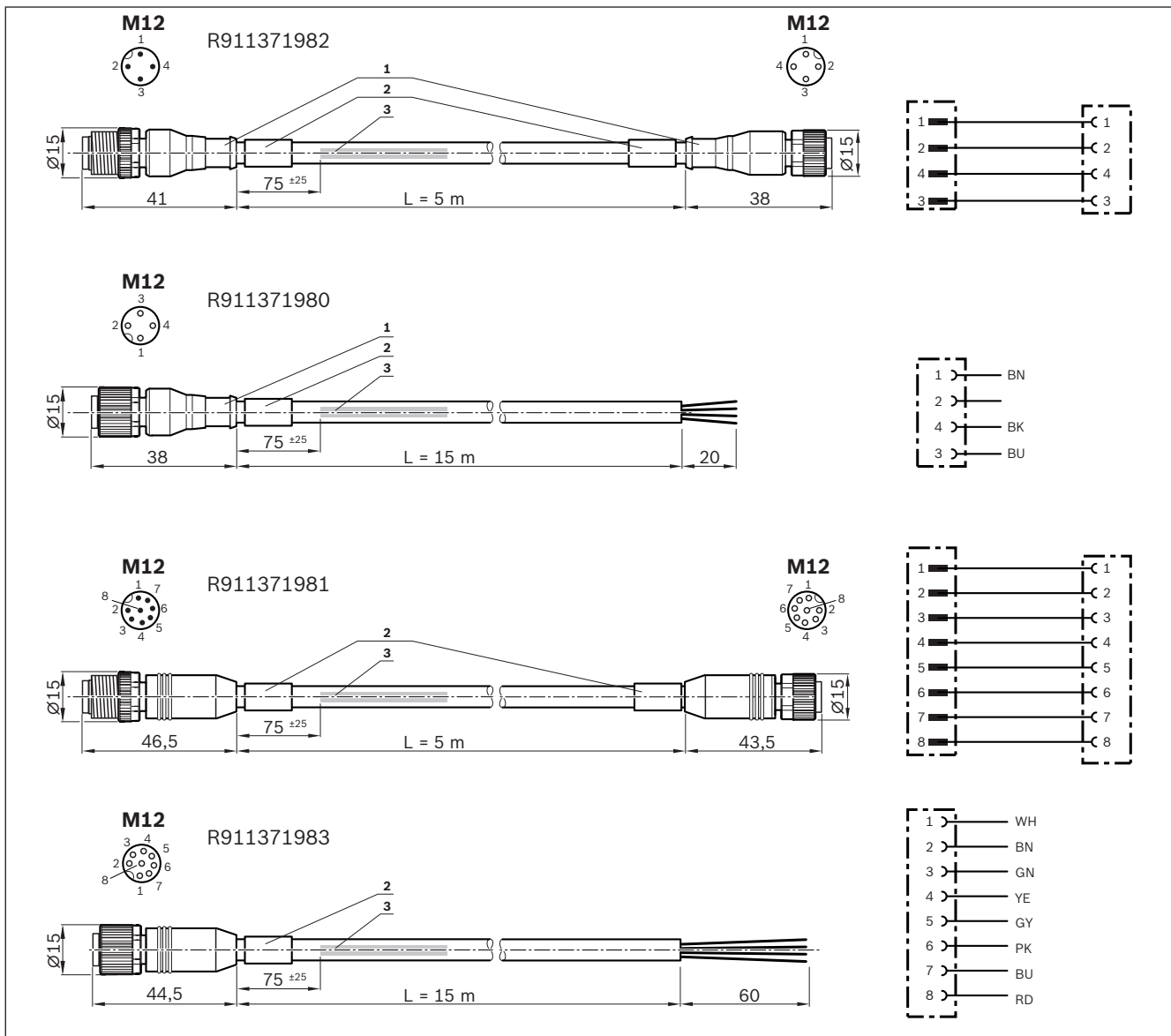
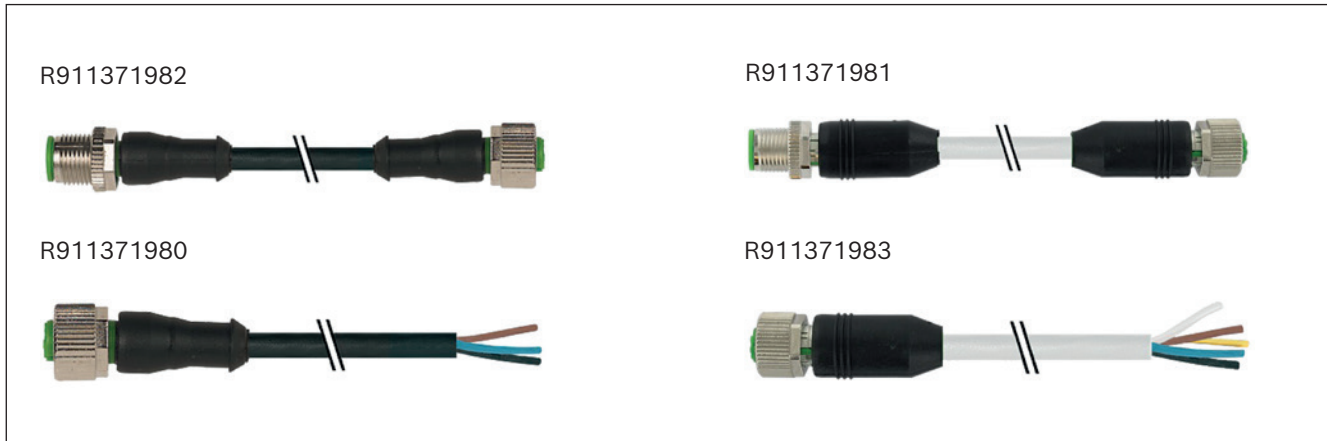

Use	For passive distributor R911344592	For passive distributors R901425737 / R901429917
Retainer plate	R913047341	-
Designation	7000-99061-0000000	-
Set	1 unit	-
Screw plug	-	R913047322
Designation	-	3858627
Set	-	10 units

Extensions for passive distributor



1) Contour for conduit pipe with inner diameter of 10
 2) Cable grommet
 3) Cable print per ordering specification 7000-08001

Material numbers/technical data

Use	Extension cable for passive distributor R911344592		Extension cable for passive distributors R901425737 / R901429917	
Material number	R911371982	R911371980	R911371981	R911371983
Designation	7000-40021-6540500	7000-12221-6541500	7000-48001-3770500	7000-17041-3771500
Length	5.0 m	15.0 m	5.0 m	15.0 m
Connection type 1	Female connector, straight, M12x1, 4-pin		Female connector, straight, M12x1, 8-pin	
Connection type 2	Male connector, straight, M12x1, 4-pin	Unassembled cable end	Straight connector, M12x1, 8-pin	Unassembled cable end
Function indicator	-			
Operating voltage indicator	-			
Type of cable	PUR black		PUR gray	
Operating voltage	30 V AC/DC			
Operating current per contact	max. 4 A per contact		max. 2 A per contact	
Suitable for drag chains	✓			
Torsion-resistant	✓			
Weld spark-resistant	✓			
Cable cross-section	4x0.34 mm ²		8x0.34 mm ²	
Cable diameter D	4.7 +/- 0.2 mm		6.2 +/- 0.3 mm	
Static bending radius	≥ 5 x D			
Dynamic bending radius	≥ 10 x D			
Bending cycles	> 10 mil.			
Max. permissible travel speed	3.3 m/s for 5 m travel range (typ.), up to 5 m/s for 0.9 m travel range			
Max. permissible acceleration	≤ 30 m/s ²			
Ambient temperature fixed ext.	-40 °C to +80 °C (90 °C max. 10000 h)			
Ambient temperature flexible ext.	-25 °C to +80 °C (90 °C max. 10000 h)			
Protection class	IP67 (inserted and bolted)			
Certifications and approvals	    			

Combination examples

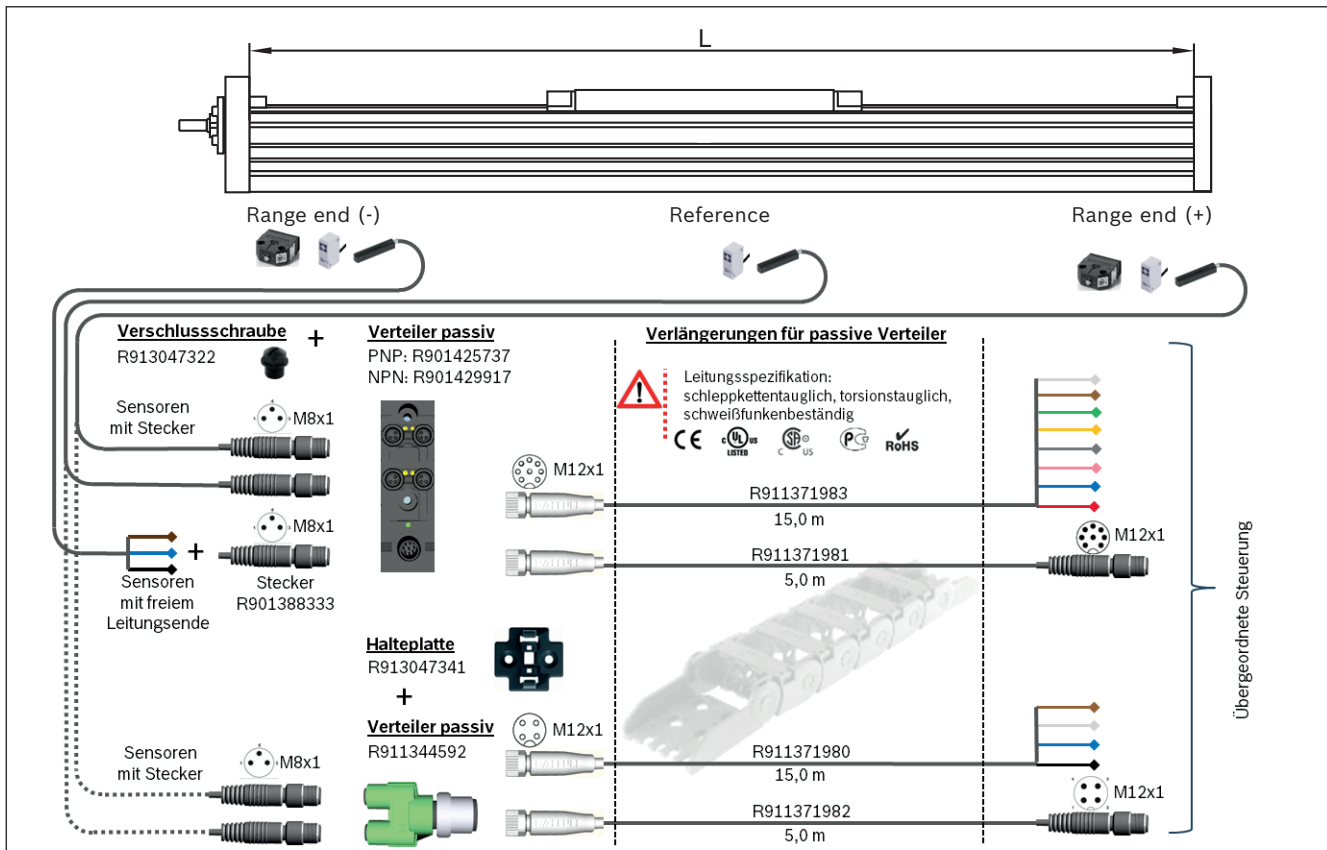
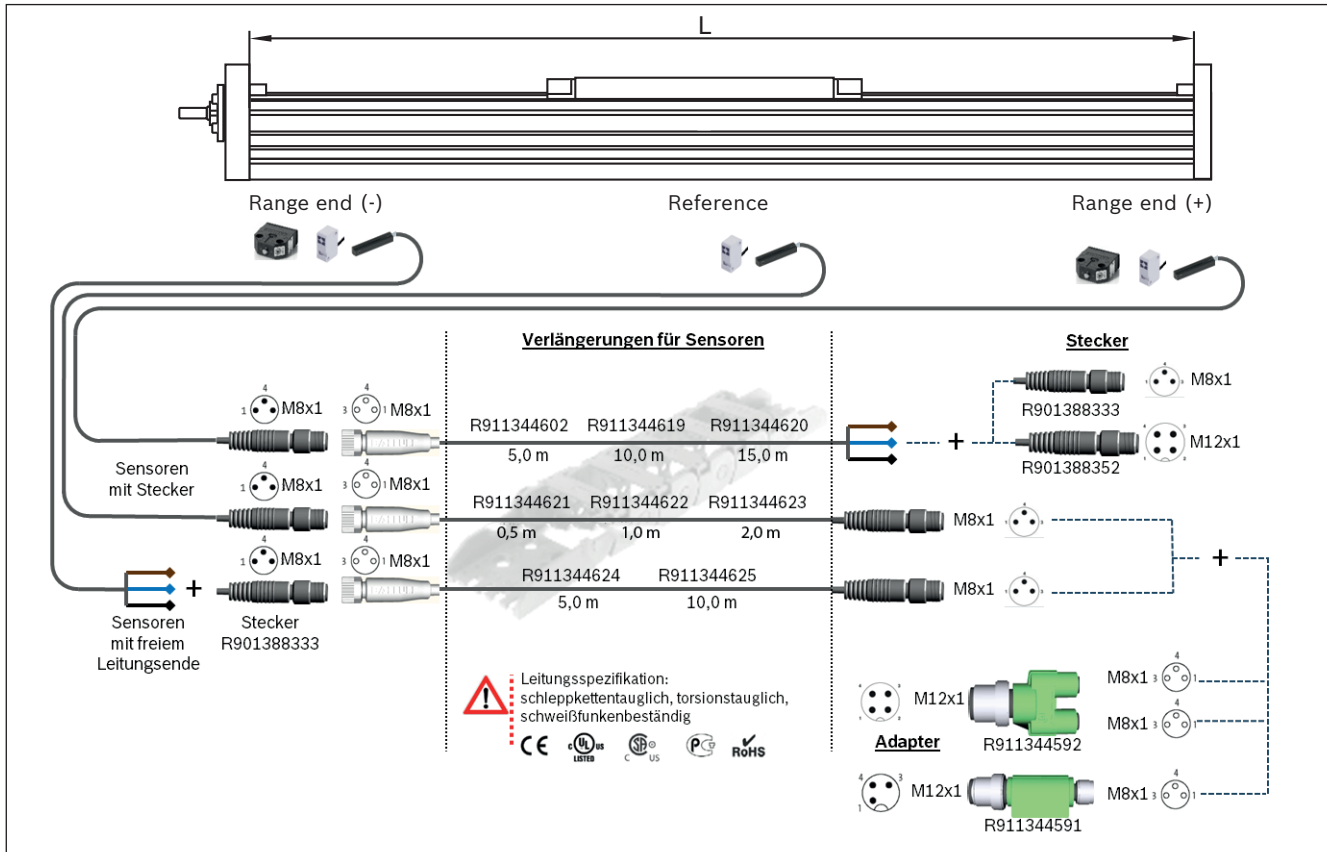

Switch system accessories

Integrated measuring system IMS-A

The IMS-A measuring system offers the following advantages:

- ▶ No additional space required.
- ▶ No additional mounting surfaces required for the measuring system.
- ▶ No measurement inaccuracies due to parallelism offset between the measuring system and the guide system.
- ▶ Full integration of the measuring system components into the guide means no complex mounting or tuning work is needed.
- ▶ The runner block, scanner and guide rail with scale can be replaced individually during servicing.
- ▶ Interfaces: HIPERFACE or DRICE-CLiQ.
- ▶ Connecting cable on the side of the carriage.

Inductive Measuring Principle

- ▶ Contact-free scanning ensures zero maintenance
- ▶ Resistant to water, oil, dust, shavings, etc.
- ▶ Insusceptible to magnetic fields

Absolute Measuring Principle

- ▶ Precise, absolute position detection thanks to an additional absolute code band
- ▶ No battery necessary for buffering the absolute information

Scale

- ▶ The scales (8/9) are integrated in the guide rail.
- ▶ These consist of a steel mesh band (Pitch = 1000 µm)
- ▶ An absolute code band is integrated for absolute position detection.
- ▶ The cover (10) (stainless-steel band) protects the scale (8/9) from contamination.

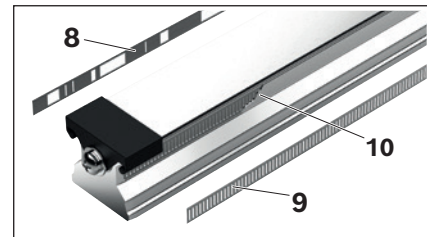

Delivery form MKx-xxx-NN-3

- ▶ IMS-A connector is always on the right (note the viewing direction)

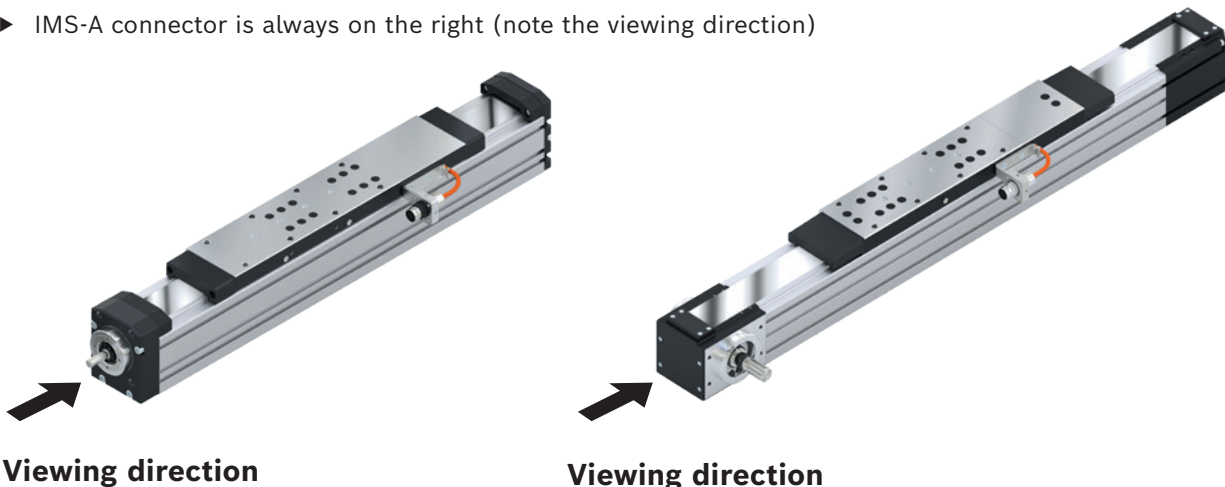

Structural design

- 1 Guide rail with scale, reference marks or absolute code band
- 2 Front seal
- 3 Support plate
- 4 Scanner
- 5 Adapter plate (fixed to the runner block)
- 6 runner block
- 7 Cables and connectors

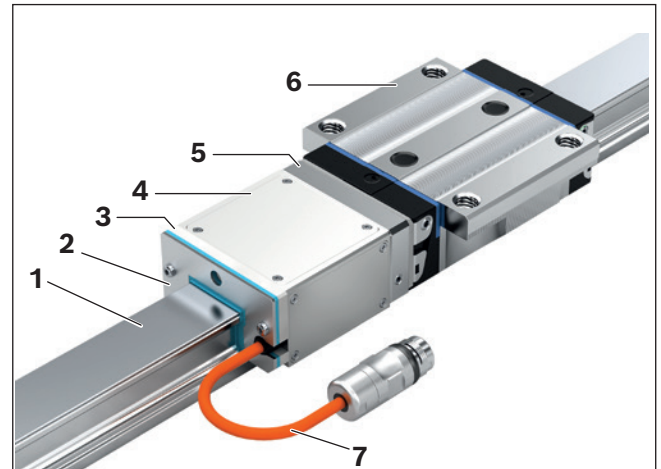

Technical data

System accuracy

Scale	Scanner	
	Interpolation accuracy (μm)	Repeatability (μm)
Accuracy class $\pm 5 \mu\text{m}/\text{m}$	± 0.75	± 0.25

The precise accuracy of the scale is provided in the included measurement report. To determine the accuracy of the system, the accuracy classes of the scale, the interpolation accuracy and repeatability are to be added together.

IMS-A		
Interface (signal)	HF	DQ
Resolution of the digital interface (μm)	1.250	0.025
Dissolvability of the $1 V_{SS} / 40 \mu\text{m}$ signal (μm)	0.025	-

Technical data

	Ball rail system	Comment
Maximum travel speed	5 m/s	
Acceleration a_{max}	500 m/s ²	
EMC	Interference immunity: EN 61326-1: 2006 Emitted interference: EN 61000-6-2, Class B	CE-marking
RoHS compliant	yes	
UL compliant	yes	

For further information, see the "Integrated Measuring System IMS" catalog

Additional information

Operating conditions

Normal operating conditions

Ambient temperature with Bosch Rexroth servo motor	0 °C ... 40 °C, above 40 °C loss of performance
Ambient temperature for mechanical system (no dropping below dew point)	-10 °C ... 60 °C
Travel range s_{\min} ¹⁾	See "Technical data" tables MKK/MKR/MLR
Soiling	Not permissible

¹⁾ Minimum travel range to ensure a reliable lubrication distribution.

Required and supplementary documentation

For further instructions and information, please refer to the documentation for this product.

PDF files of these documents can be found on the Internet at:
www.boschrexroth.com/mediadirectory.

We would also be happy to send you the documents that you want.

If you are unsure about using this product, please contact Bosch Rexroth.

Lubrication-MKx-165-NN-2

Note on lubrication

Linear modules (MKx-165-NN-2) come with initial greasing with Dynalub 510 and are only designed for grease lubrication using a manual grease gun. Maintenance is limited to the maintenance lubrication of the integrated ball rail system and the Rexroth ball screw assembly (on MKK) via one of the two funnel-type lube nipples (DIN 3405-A M6)

⚠ Do not use lubricants with solid particles (e.g. graphite or MoS₂ additives).

⚠ For short stroke lubrication (< s_{min} mm), please consult us.

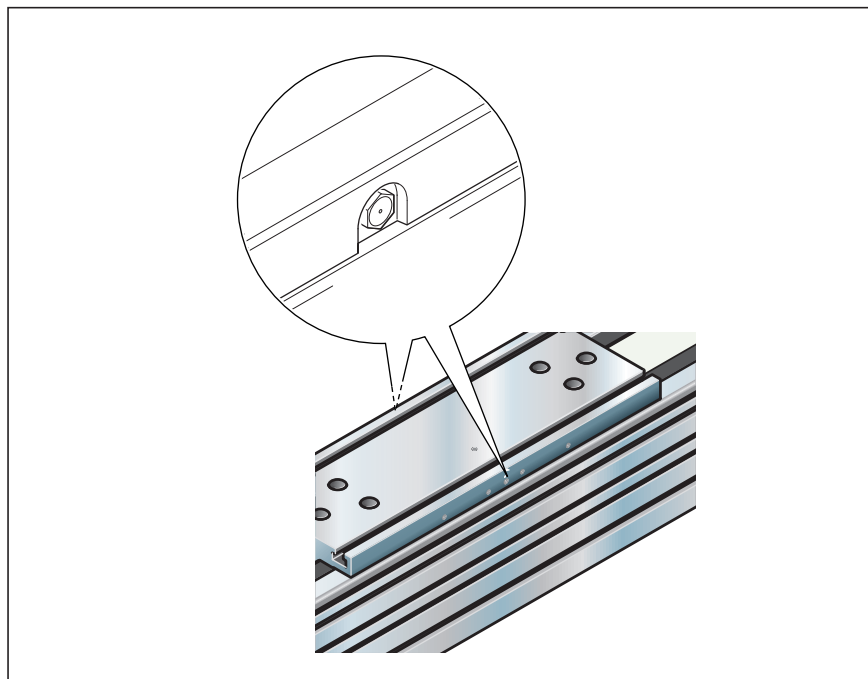

Recommended lubricants

For maintenance lubrication and maintenance lubrication intervals, see the linear module instructions

MKK/MKR	Grease (DIN)	Consistency class DIN 51818	Recommended grease
-165	KP2K-20 (DIN 51825)	NLGI 2	Dynalub 510

Grease

Consistency class NLGI 2 in accordance with DIN 51818

We recommend:

Dynalub 510 (Bosch Rexroth)
 Cartridge (400 g) R341603700
 Container (25 kg) R341603500

Can also be used

Elkalub GLS 135 / N2 (Chemie-Technik)
 Tribol GR 100-2 PD (Castrol)

Lubrication-MLR-xxx-NN-3

Linear modules with cam roller guide (MLR) are designed for oil lubrication. With initial greasing on delivery.

MLR	Lube nipple	Oil
-080	DIN 3405-A M6	ISO VG 1000
-110		

Accessories (nozzle pipe) for manual grease gun, see chapter "Attachments and accessories"

168 Linear modules

Additional information

Lubrication MKx-xxx-NN-3

Lubrication version	LSS		LPG	
Size	MKx-065 / -080 / -110 / -140 / -145	MKx-040	MKx-065 / -080 / -110 / -140 / -145	MKx-040
Basic lubrication	Dynalub 510	Dynalub 520	Preserved, basic lubrication required (see instructions)	
Consistency class	NLGI 2 (DIN 51818)	NLGI 00 (DIN 51818)	-	
Identification	KP2K-20 (DIN 51825)	GP00K-20 (DIN 51826)	-	
Lubrication with grease gun	yes	yes	yes	
Prepared for connection to central lubrication systems	-			
Recommended lubricants	Dynalub 510 (Grease lubricant) (NLGI2 DIN 51818)	Dynalub 520 (Liquid grease) (NLGI00 DIN 51818)	Dynalub 510 (Grease lubricant) (NLGI2 DIN 51818)	Dynalub 520 (Liquid grease) (NLGI00 DIN 51818)
Features	<ul style="list-style-type: none"> • Good water resistance • Corrosion protection • Temperature range: -20 °C to +80 °C 			
Material numbers	R3416 037 00 (400 g cartridge)	R3416 043 00 (400 g cartridge)	R3416 037 00 (400 g cartridge)	R3416 043 00 (400 g cartridge)
	R3416 035 00 (25 kg container)	R3416 042 00 (5 kg bucket)	R3416 035 00 (25 kg container)	R3416 042 00 (5 kg bucket)
Alternative lubricants	<ul style="list-style-type: none"> • Tribol GR 100-2 PD • Elkalub GLS 135/N2 	<ul style="list-style-type: none"> • Tribol GR 100-00 PD • Elkalub GLS 135/N00 	<ul style="list-style-type: none"> • Tribol GR 100-2 PD • Elkalub GLS 135/N2 • Tribol GR 100-00 PD • Elkalub GLS 135/N00 • Dynalub 520 • Klüberplex BEM 34-132 	<ul style="list-style-type: none"> • Tribol GR 100-00 PD • Elkalub GLS 135/N00
Alternative lubricants with H1 approval	-		<ul style="list-style-type: none"> • Berulub FG H2 SL • Cassida Grease EPS2 • VP 874 	<ul style="list-style-type: none"> • Berulub FB 34-00 • Elkalub GLS 367/N00

Notes on lubrication

- ▶ Follow the product instructions.
- ▶ Do not use lubricants with solid particles (e.g. graphite or MoS₂).
- ▶ If you use different lubricants than the ones specified, relubrication intervals may be shorter and performance may decrease with short stroke and load ratio; in addition, chemical interactions can take place between the plastics, lubricants and preservative agents. Single-line central lubrication systems also need to be able to pump these lubricants.
- ▶ If using a central lubrication system, make sure all lines and elements are filled with lubricant all the way to the connection to the consumer (carriage) and that there are no air bubbles.
- ▶ Lubricant reservoirs should contain an agitator to ensure the lubricant can flow (avoids hardening in the reservoir).
- ▶ For relubrication, it is not possible to switch from grease to oil lubrication and vice-versa.
- ▶ If environmental factors such as contamination, vibrations, impact loads, etc. are present, we recommend shorter relubrication intervals. Even under normal operating conditions, relubrication is required every two years due to grease aging.
- ▶ Rexroth recommends piston distributors by SKF. These should be installed as close to the carriage lube fittings as possible. Avoid long lines (no longer than 1 m) and narrow line diameters. Install the lines at a gradient.
- ▶ If other consumers are connected to the single-line lubrication system, the weakest link in this chain determines the lubrication cycle.
- ▶ Excess lubricant can accumulate inside of the linear module or flow out and may lead to contamination of the environment.
- ▶ Never put linear modules into operation without basic lubrication.

LCF	LCO
MKx -040 / -065 / -080 / -110 / -140 / -145	MKx -040 / -065 / -080 / -110 / -140 / -145
required, see instructions	required, see instructions
NLGI 00 (DIN 51818)	-
GP00K-20 (DIN 51826)	-
-	-
<ul style="list-style-type: none"> only via single-line piston distributor system smallest permissible piston distributor size: MKx -040, -065, -080, -145: 0.2 cm³; MKx -110, -140: 0.3 cm³ 	<ul style="list-style-type: none"> only via single-line piston distributor system smallest permissible piston distributor size: MKx -040, -065: 0.2 cm³; MKx -080: 0.4 cm³; MKx -110, -140, -145: 0.6 cm³
Dynalub 520 (liquid grease) (NLGI00 DIN 51818)	Shell Tonna S3 M220 (lubricant oil)
<ul style="list-style-type: none"> Good water resistance Corrosion protection Temperature range: -20 °C to +80 °C 	<ul style="list-style-type: none"> Special demulsifying oil CLP or CGLP as per DIN 51517-3 for machine bed tracks and tool guides A blend of highly refined mineral base oils and additives Can be used even when mixed with significant quantities of metalworking fluids
R3416 043 00 (400 g cartridge)	-
R3416 042 00 (5 kg bucket)	-
<ul style="list-style-type: none"> Tribol GR 100-00 PD Elkalub GLS 135/N00 	<ul style="list-style-type: none"> Special demulsifying oil CLP or CGLP as per DIN 51517-3 for machine bed tracks and tool guides
-	-

⚠ Use of lubricants with H1 approval:

Loss of H1 approval

H1 lubricants or release agents (preservative agents) only have H1 approval if they are separated and unmixed (including at the lubrication point). A blend of two H1 approval lubricants or separating agents does not have H1 approval.

No approval or authorization for use in the food industry

Because of the use of H1 lubricants, the linear modules do not have authorization or approval for the food industry.

Components lubricated at the factory

Components lubricated by the manufacturer at the factory, such as deep-groove ball bearings, do not use H1 lubricants.

⚠ Linear modules with Dynalub 520 (NLGI 00 consistency class) initial greasing must not be lubricated with lubricants of consistency class NLGI 2!

Re-lubrication quantity and re-lubrication interval ⇒ Instructions linear modules

Lube connection

Linear module	Lube nipple (with "LSS/LPG lubrication")	Connector (with "LCF/LCO lubrication")
MKK/MKR-040	DIN 3405-A M3	See dimension drawing
MKK/MKR-065 / -080 / -110 / -140 / -145	DIN 3405-A M6	

Straight connectors¹⁾ for plastic tubes and metal pipes

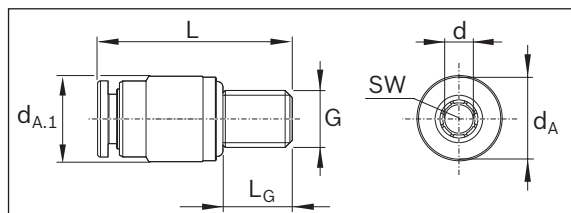

Material number	Dimensions (mm)							Mass (g)
	d _A	d _{A.1}	d±0.1	G	L	L _G	SW	
R341707309 ²⁾	6.5	6.5	3	M3	16.0	5	1.5	1.6
R341707509	9	9	4	M6	24.5	8	2.5	4.9

¹⁾ Max. lubrication pressure: 30 bar (exerting slow pressure with manual grease gun)

²⁾ MKK/MKR-040

Additional information

Documentation

Standard report Option 001

The standard report serves to confirm that the checks listed in the report have been carried out and that the measured values lie within the permissible tolerances.

- Checks listed in the standard report:
- Functional checks of mechanical components
 - Functional checks of electrical components
 - Design is in accordance with order confirmation

Measurement of frictional torque of complete system

Option 002 (includes option 001)
The friction torque is measured over the entire travel range.

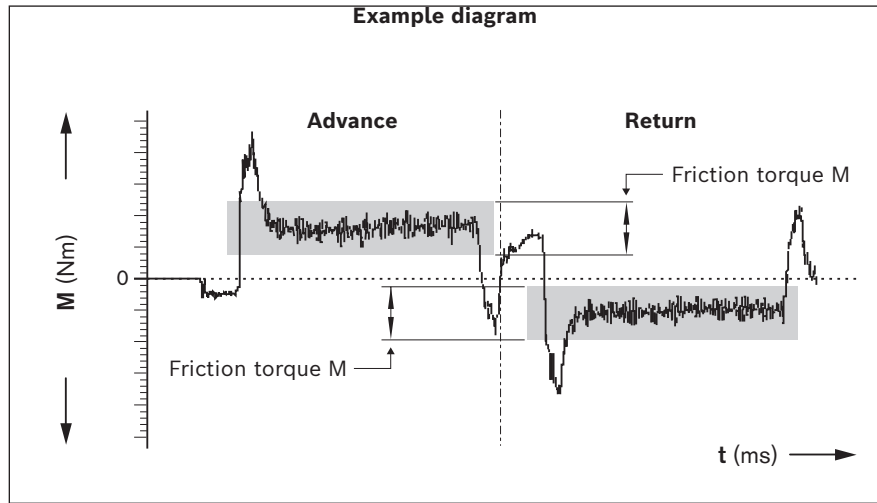

Lead deviation of the ball screw assembly for linear modules MKK

Option 003 (includes option 001)
In addition to graphical representation (see illustration), a measurement report is also supplied in table form.

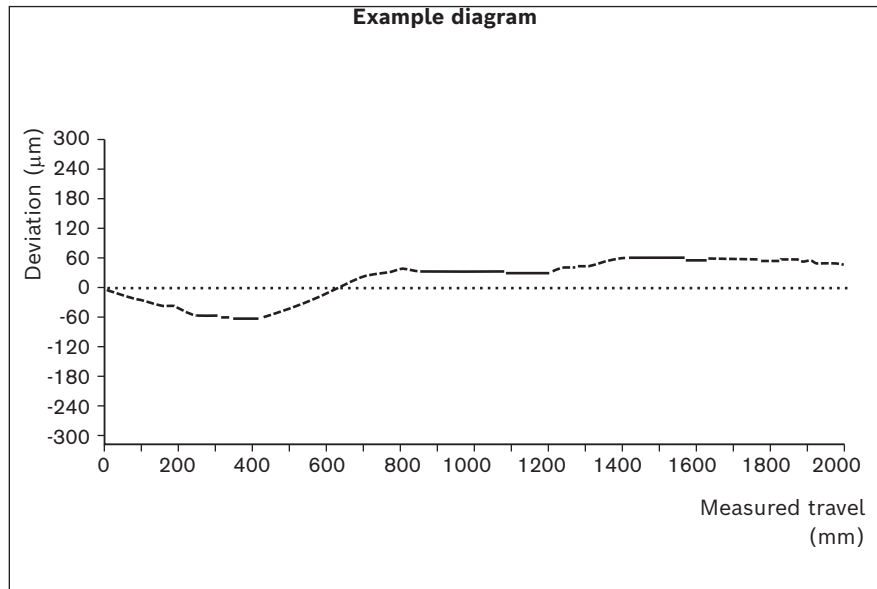

Positioning accuracy according to VDI/DGQ 3441 Option 005 (includes option 001)

Measurement points are selected at irregular intervals along the travel range. This enables even periodical deviations to be detected during positioning.

Each measurement point is approached several times from both sides. This provides the following parameters.

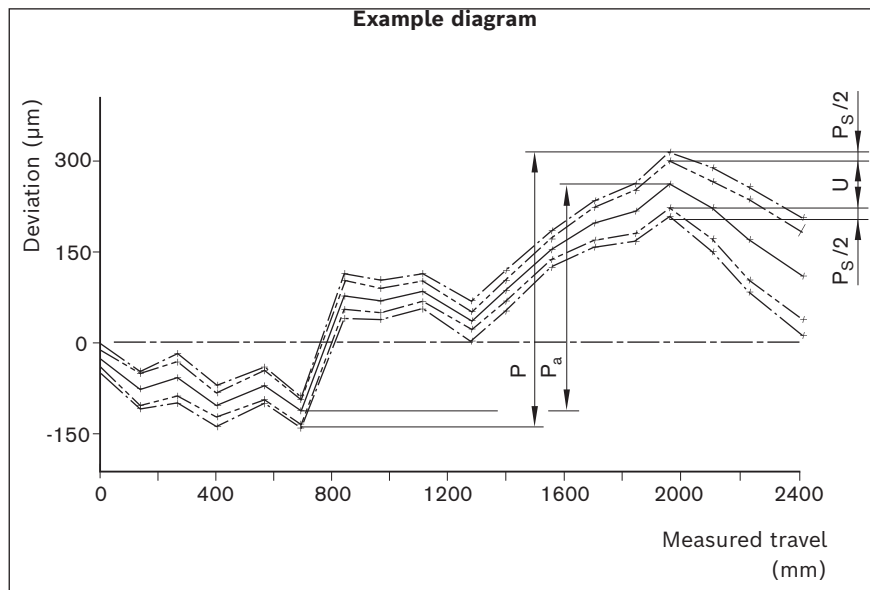

Positional uncertainty P

The positional uncertainty equals the total deviation.

It encompasses all the systematic and random deviations in relation to positioning.

Positional uncertainty is a parameter for the positioning accuracy and corresponds to the total deviation. It encompasses all the systematic and random deviations in relation to positioning.

Positional uncertainty takes the following characteristic values into consideration:

1. – Position deviation
2. – Reversal range
3. – Position variation range

Position deviation P_a

The position deviation equals the maximum difference arising between the mean values of all the measurement points.

It describes systematic deviations.

Reversal range U

The reversal range corresponds to the difference in mean values of the two approach directions. The reversal range is determined at every measurement point.

It describes systematic deviations.

Position variation range P_s

The position variation range describes the effects of random deviations. It is determined at every measurement point.

Additional information

Parameterization (commissioning)

The nameplate contains reference information on the production of the linear motion system as well as technical commissioning parameters.

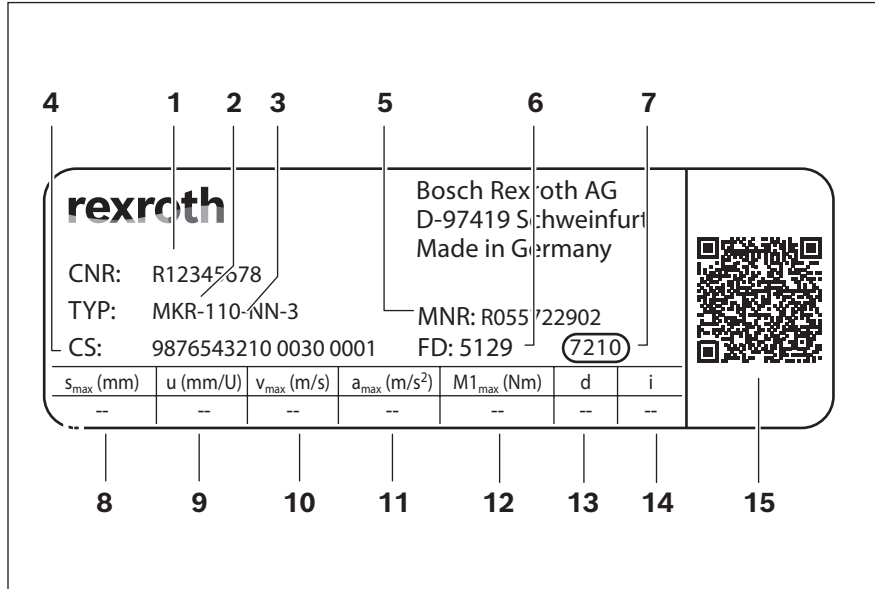

1	CNR	Customer's material number
2	TYP	Short product name
3	110	Size
4	CS	Customer information
5	MNR	Material number
6	FD	Date of manufacture
7	7210	Manufacturing location
8	s_{max}	Maximum travel range
9	u	Feed constant without motor attachment
10	v_{max}	Maximum speed
11	a_{max}	Maximum acceleration rate
12	$M1_{max}$	Maximum drive torque at motor journal
13	d	Direction of motor rotation to travel in positive (+) direction CW = Clockwise CCW = counterclockwise

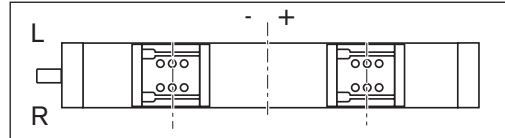
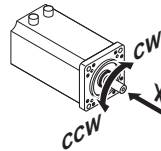

14	i	Gear ratio
15		QR code

Calculation principles

Calculation principles	166
Length calculation	166
Note on dynamic load capacities and moments	167
Maximum permissible load	168
Linear guide service life	168
Service life of the ball screw assembly or fixed bearing	169
Drive sizing	170
Basic principles	171
Drive sizing with motor shaft as reference point	172
General motor preselection	174
Calculation examples	176
Calculation example MKK with belt side drive	176
Calculation example MKR with gear reducer	179
Abbreviations	182

Length calculation of the linear system

For length calculation values, see the chapter "Technical data" for the desired linear module (MKK/MKR/MLR)

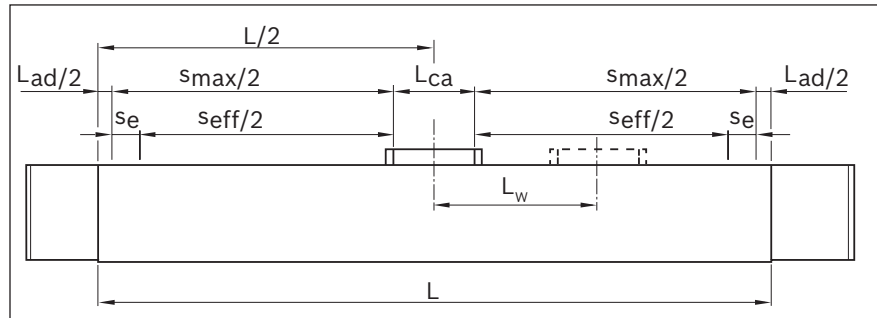

$$L = s_{eff} + 2 \cdot s_e + L_{ca} + L_{ad} + L_w$$

MKK -165

$$L = (s_{eff} + 2 \cdot s_e) \cdot 1.17^* + L_{ca} + L_{ad}$$

* for cover with bellows

Effective stroke

$$s_{eff} = s_{max} - 2 \cdot s_e$$

Stroke: maximum distance from carriage center to the outer-most switch activation points.

Excess travel: Excess travel must be greater than the braking distance.

The acceleration travel can be assumed as a guideline value for the braking distance.

Mass of the linear system

Weight calculation:

- ▶ without motor
- ▶ without switch mounting
- ▶ without motor attachment

$$m_s = k_{g\ fix} + k_{g\ var} \cdot L + m_{ca}$$

Note on dynamic load capacities and moments

Suitable loads

Regarding the desired service life, general loads for F_{mgw} , F_{mbs} should not exceed around 20% of the dynamic characteristic values (C_{gw} , C_{bs}). See "Project planning" chapter. Do not exceed the technical data for the linear motion system.

Determination of the dynamic load capacities and moments is based on a total travel of 100000 m. Often only 50000 m of total travel are actually stipulated. For comparison: Multiply values C , M_t and M_L by a factor of 1.26.

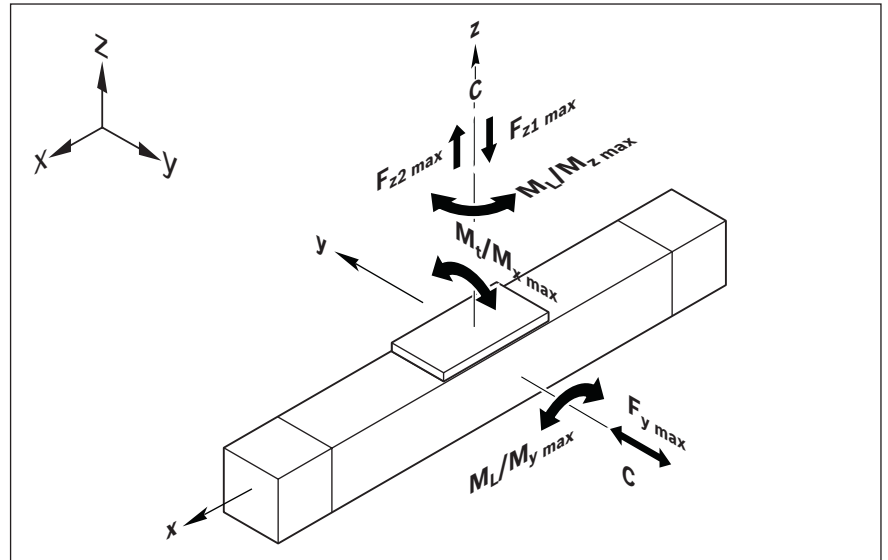

Application point of the effective force (z_1)

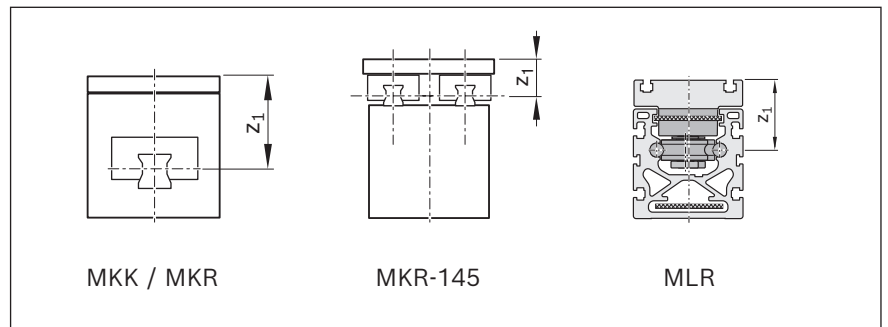

Modulus of elasticity E

$E = 70\,000 \text{ N/mm}^2$

Deflection

⚠ Do not mount or support the linear module by the cross ties or end enclosures!

⚠ f_{max} must not be exceeded! If high system dynamics are required, supports must be provided every 300 to 600 mm. (For f_{max} values, see chapter "Technical data" of the respective linear module)

A particular feature of linear modules is that they can be installed as cantilevered axes. Deflection must, however, be taken into consideration: It limits the possible load. If the maximum permissible deflection is exceeded, additional supports must be provided. The maximum permissible deflection f_{max} depends on the length L and the load F .

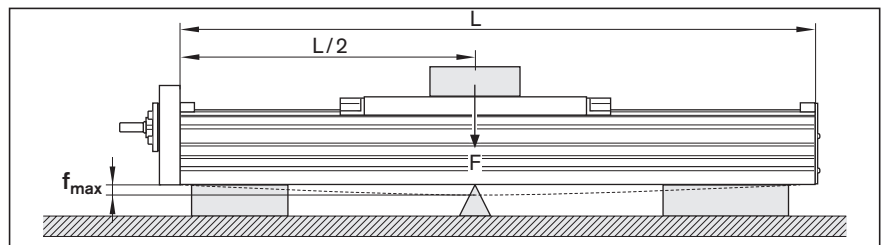

Project planning/calculation

Maximum permissible load

When selecting linear motion systems, it is essential to consider the maximum permissible load and force tolerances according to the table. The values depend on the system. In other words, the tolerances are determined not only by the load capacities of the bearing points but are also based on design and material.

Conditions for combined loads:

$$\frac{|F_y|}{F_{y \max}} + \frac{|F_z|}{F_{z \max}} + \frac{|M_x|}{M_{x \max}} + \frac{|M_y|}{M_{y \max}} + \frac{|M_z|}{M_{z \max}} \leq 1$$

Linear guide service life

The service life of the rolling bearing points contained in a linear motion system can be calculated using the formulas given below. The roller bearing points that determine the life of a linear motion system with ball screw assembly are the linear guide, the ball screw assembly (nut) and the fixed bearing. The linear guide in the linear motion system must withstand the load as well as any process forces that occur.

⚠ The service life of the linear motion system is the separately calculated service life that is the shortest (for linear guide, ball screw assembly or fixed bearing).

Where the operating conditions vary (speed and load), the service life must be calculated using the average values v_{mrs} and F_{mrs} .

Nominal life in meters:

MKK / MKR

$$L_{gw} = \left(\frac{C_{gw}}{F_{mgw}} \right)^3 \cdot 10^5$$

MLR

$$L = \left(\frac{C_y}{F_{comb}} \right)^3 \cdot 10^5$$

Nominal service life in hours:

$$L_{hgw} = \frac{L_{gw}}{3600 \cdot v_{mgw}}$$

Dynamically equivalent load on bearing of the guideway:

$$F_{mgw} = \sqrt[3]{|F_{eff1}|^3 \cdot \frac{qt1}{100\%} + |F_{eff2}|^3 \cdot \frac{qt2}{100\%} + |F_{eff3}|^3 \cdot \frac{qt3}{100\%} + |F_{effn}|^3 \cdot \frac{qtn}{100\%}}$$

The following applies to linear motion systems:

$$F_{eff} = F_{comb}$$

Combined equivalent bearing load:

- MKK / MKR

$$F_{comb} = |F_y| + |F_z| + C_{gw} \cdot \frac{|M_x|}{M_t} + C_{gw} \cdot \frac{|M_y|}{M_L} + C_{gw} \cdot \frac{|M_z|}{M_L}$$

- MLR

$$F_{comb} = |F_y| + C_y \cdot \frac{|F_z|}{C_z} + C_y \cdot \frac{|M_x|}{M_t} + C_y \cdot \frac{|M_y|}{M_L} + C_y \cdot \frac{|M_z|}{M_L}$$

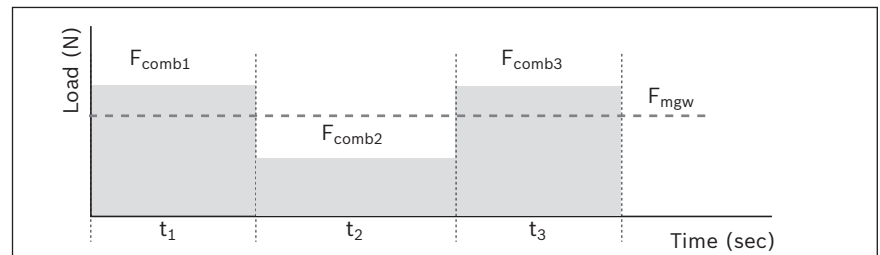

Average linear speed of the guideway:

$$v_{mgw} = \frac{|v_1| \cdot qt1 + |v_2| \cdot qt2 + \dots + |v_n| \cdot qtn}{100\%}$$

Service life of the ball screw assembly or fixed bearing

Where the operating conditions vary (rotary speed and load), the service life must be calculated using the average values F_{mbs} and n_m .

Nominal service life in revolutions:

$$L_{bs} = \left(\frac{C_{bs}}{F_{mbs}} \right)^3 \cdot 10^6$$

Nominal service life in hours:

$$L_{hbs} = \frac{L_{bs}}{60 \cdot n_m}$$

Dynamically equivalent load on bearing of the ball screw assembly:

$$F_{mbs} = \sqrt[3]{|F_{eff1}|^3 \cdot \frac{|n_1|}{n_m} \cdot \frac{q_{t1}}{100\%} + |F_{eff2}|^3 \cdot \frac{|n_2|}{n_m} \cdot \frac{q_{t2}}{100\%} + |F_{eff3}|^3 \cdot \frac{|n_3|}{n_m} \cdot \frac{q_{t3}}{100\%} + \dots + |F_{effn}|^3 \cdot \frac{|n_n|}{n_m} \cdot \frac{q_{tn}}{100\%}}$$

The following applies to the axial load F_n for linear motion systems:

$$F_{eff} = |F_n|$$

When both the load and the rotary speed vary, the average load F_{mbs} is calculated as follows:

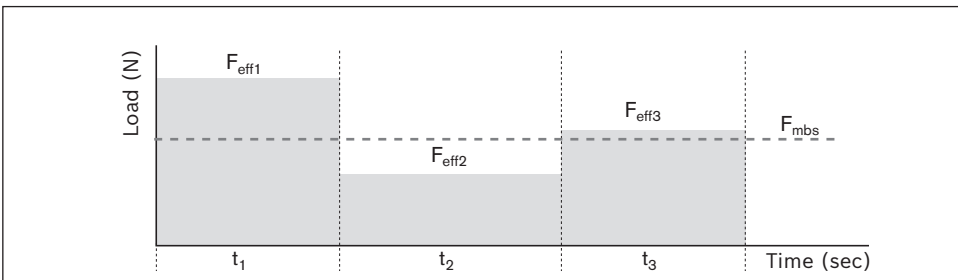

Average rotary speed of the screw:

$$n_m = \frac{|n_1| \cdot q_{t1} + |n_2| \cdot q_{t2} + \dots + |n_n| \cdot q_{tn}}{100\%} = \frac{v_{mgw} \cdot 60\,000}{P}$$

If the rotary speed varies, the average rotary speed n_m is calculated as follows:

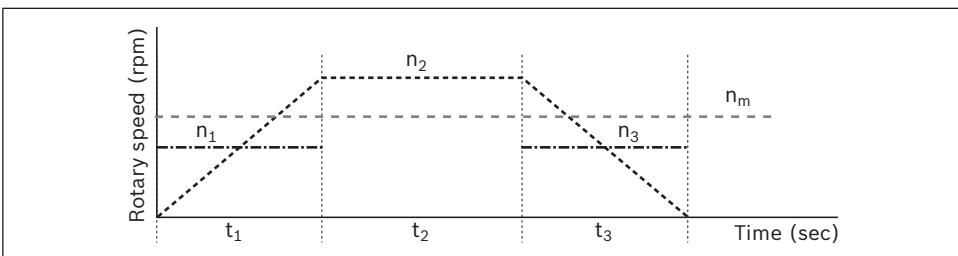

Rotary speed in acceleration and braking phases $n_{1 \dots n}$:

$$n_{1 \dots n} = \frac{n_{A1 \dots n} + n_{E1 \dots n}}{2}$$

Drive sizing

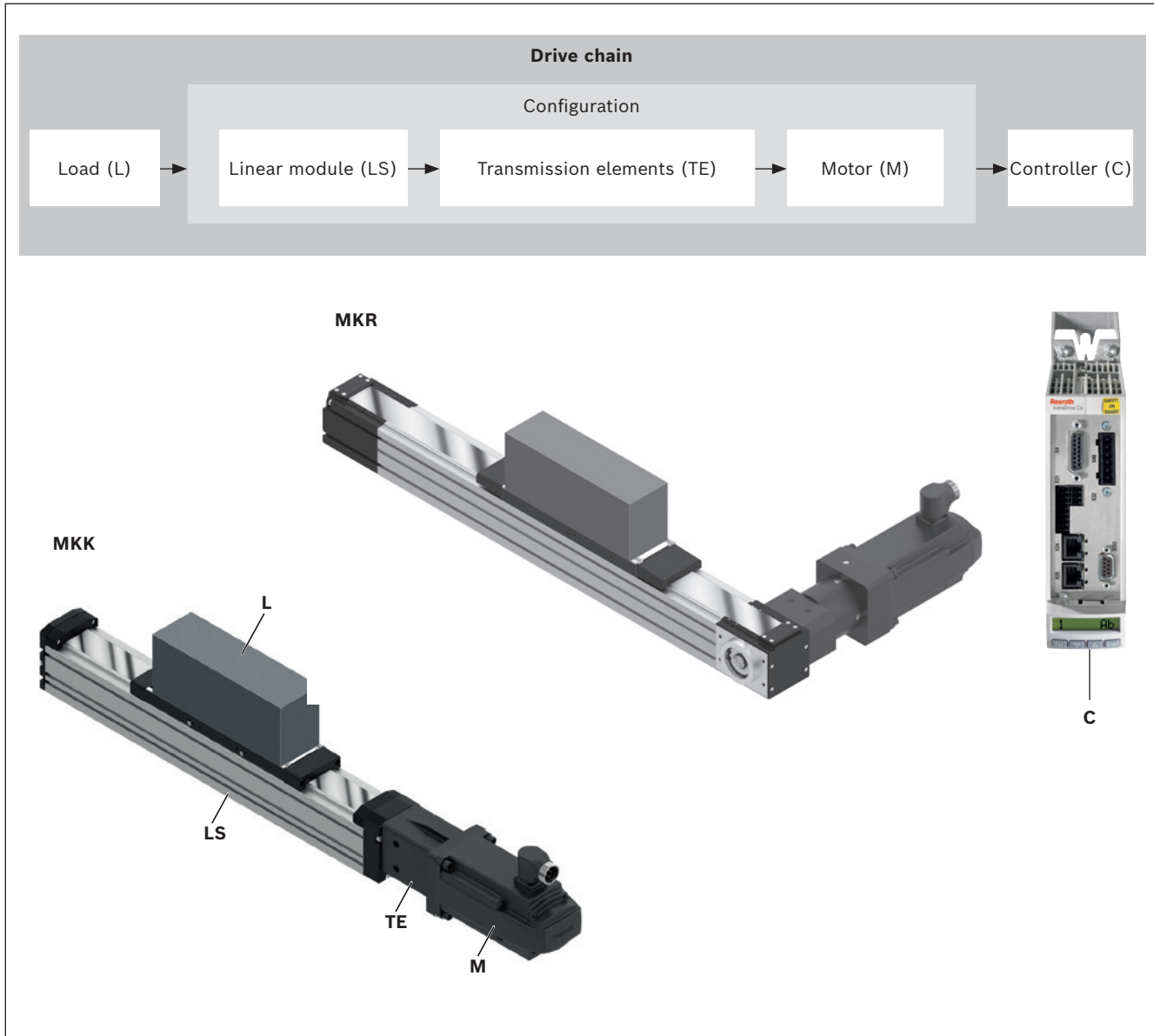

The correct dimensioning and assessment of an application requires structured consideration of the drive chain as a whole.

The basic element of the drive chain is the configuration – made up of the linear motion system, the transmission element (coupling, belt side drive or gear unit) and the motor – which can be ordered in that constellation in the catalog.

Basic principles

For drive sizing, the drive chain can be divided into mechanical system and drive system.

The mechanical system includes the physical components – linear motion system and the transmission elements (belt side drive, coupling) – and the load to be carried.

The electric drive is a motor-controller combination with corresponding performance data.

The sizing and/or dimensioning of the electric drive is done taking the motor shaft as a reference point.

For drive sizing, limits must be taken into account as well as base values. The limits must not be exceeded in order to avoid damaging the mechanical components.

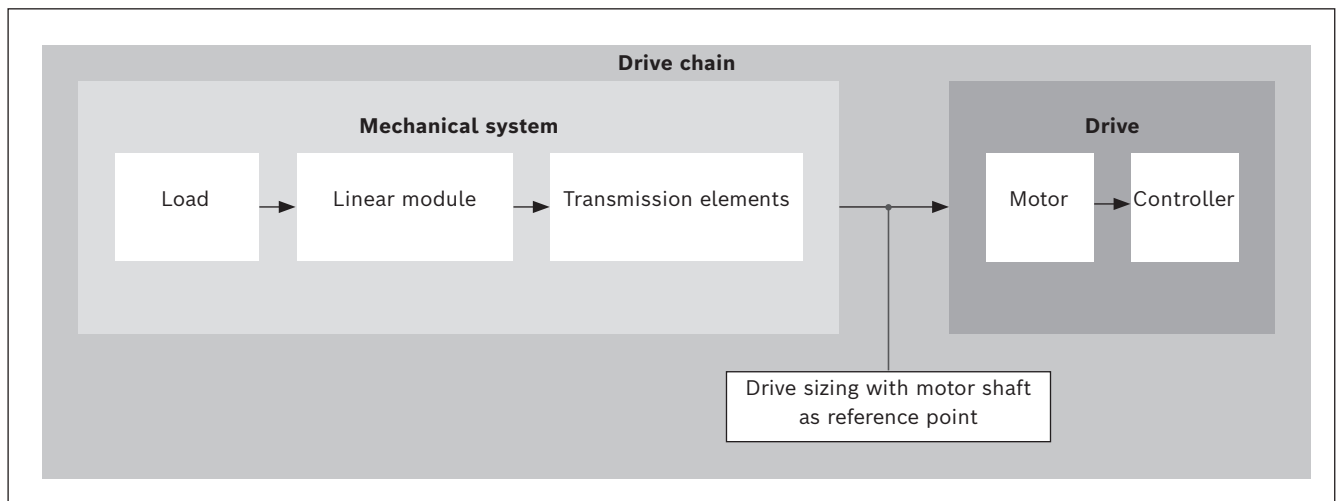

Technical data and formula symbols for the mechanical system

For every component (linear motion system, coupling, belt side drive, gear unit), the corresponding maximum permissible limits for drive torque and speed, and the base values for friction torque and mass moment of inertia have to be used.

The following technical data with the associated formula symbols are used when considering the basic mechanic system requirements in the design calculations for drive sizing. The data listed in the table below can be found in the chapter "Technical data" or is determined using formulas based on the descriptions on the following pages.

	Mechanical system				
	Load	Linear motion system	Transmission element		
			Coupling	Belt side drive	Gearing
Weight moment (Nm)	$M_g^{6)}$	—	—	—	—
Friction torque (Nm)	— ⁵⁾	$M_{Rs}^{3)}$	—	$M_{Rsd}^{3)}$	$M_{Rge}^{3)}$
Mass moment of inertia (kg/m ²)	$J_t^{1)}$	$J_s^{2)}$	$J_c^{3)}$	$J_{sd}^{3)}$	$J_{ge}^{3)}$
max. permissible speed (m/s)	—	$v_{max}^{4)}$	—	—	—
max. permissible rotary speed (rpm)	—	$n_p^{1)}$	—	—	$n_{ge}^{3)}$
Max. permissible drive torque (Nm)	—	$M_p^{4)}$	$M_{cN}^{3)}$	$M_{sd}^{3)}$	$M_{ge}^{3)}$

1) Determine the value using the appropriate formula
 2) Length-dependent value, determined using the appropriate formula
 3) Use the value from the table
 4) Length-dependent value, to be read off the graph
 5) Any additional process forces are to be taken into consideration as load moments
 6) For vertical installation position: Determine the value using the appropriate formula

Project planning/calculation

Drive sizing with motor shaft as reference point

When sizing the drive, all relevant design calculation values for the mechanical components in the drive chain have to be determined and be expressed/reduced to the motor shaft. For a combination of mechanical components within the drive chain, this will result in one value for each of the following:

- ▶ Friction torque M_R
- ▶ Mass moment of inertia J_{ex}
- ▶ Max. permissible speed v_{mech} (max. permissible rotary speed n_{mech})
- ▶ Max. permissible drive torque M_{mech}

Determination of the values for each mechanical component in the drive chain based on the motor shaft as a reference point

Linear modules MKK	
Friction torque M_R	
For motor attachment via flange and coupling	$M_R = M_{Rs}$
For motor attachment via belt side drive	$M_R = M_{Rsd} + \frac{M_{Rs}}{i}$
Mass moment of inertia J_{ex}	
For motor attachment via belt side drive	$J_{ex} = J_{sd} + \frac{(J_s + J_t)}{i^2}$
For motor attachment via flange and coupling	$J_{ex} = J_s + J_t + J_c$

Linear modules MKR	
Friction torque M_R	
For motor attachment via gear	$M_R = M_{Rge} + \frac{M_{Rs}}{i}$
Mass moment of inertia J_{ex}	
For direct motor attachment (without gear)	$J_{ex} = J_s + J_t$
For motor attachment via gear	$J_{ex} = J_{ge} + \frac{(J_s + J_t)}{i^2}$

Mass moment of inertia of the linear motion system

$$J_s = (k_{J \text{ fix}} + k_{J \text{ var}} \cdot L) \cdot 10^{-6}$$

Determination of translative mass moment of inertia of the external load

$$J_t = m_{ex} \cdot k_{J \text{ m}} \cdot 10^{-6}$$

Maximum permissible speed v_{mech} or maximum permissible rotary speed n_{mech}

The lowest of all the values for permissible speed or rotary speed of all mechanical components contained in the drive chain determines the maximum permissible speed of the mechanical system which has to be taken into consideration as the upper limit for the drive when sizing the motor.

Depending on the system, the maximum permissible speed/rotary speed of the linear motion system with ball screw assembly is always below the limits for the coupling or belt side drive components, meaning it determines the maximum permissible speed of the mechanical system.

Linear modules MKK	
Maximum permissible speed	$v_{\text{mech}} = v_{\text{max}}$
Maximum permissible rotary speed	
For motor attachment via flange and coupling	$n_{\text{mech}} = \frac{v_{\text{mech}} \cdot 1,000 \cdot 60}{P}$
For motor attachment via belt side drive	$n_{\text{mech}} = \frac{v_{\text{mech}} \cdot i \cdot 1,000 \cdot 60}{P}$

Linear modules MKR		
Maximum permissible speed		
For direct motor attachment (without gear)	$v_{\text{mech}} = v_{\text{max}}$	$v_{\text{mech}} = \frac{n_{\text{mech}} \cdot \pi \cdot d_3}{1000 \cdot 60}$
For motor attachment via gear	$v_{\text{mech}} = \frac{n_{\text{mech}} \cdot \pi \cdot d_3}{i \cdot 1000 \cdot 60}$	
Maximum permissible rotary speed		
For direct motor attachment (without gear)	$n_{\text{mech}} = \frac{v_{\text{mech}} \cdot 1,000 \cdot 60}{\pi \cdot d_3}$	$n_{\text{mech}} = n_p$
For motor attachment via gear	$n_p = \frac{v_{\text{max}} \cdot 1000 \cdot 60}{\pi \cdot d_3}$	$n_{\text{mech}} = \text{minimum}(n_p \cdot i; n_{ge})$

Project planning/calculation

Maximum permissible drive torque M_{mech}

The lowest (minimum) of all the values for permissible drive torque of all mechanical components contained in the drive chain determines the maximum permissible drive torque of the mechanical system which has to be taken into consideration as the upper limit for the drive when sizing the motor.

Linear modules MKK	
For motor attachment via flange and coupling	$M_{mech} = \text{minimum} (M_{cN}; M_p)$
For motor attachment via belt side drive	$M_{mech} = \text{minimum} (M_{sd}; \frac{M_p}{i})$

Linear modules MKR	
For direct motor attachment (without gear)	$M_{mech} = M_p$
For motor attachment via gear	$M_{mech} = \text{minimum} (\frac{M_{ge}}{i}; \frac{M_p}{i})$

⚠ When considering the complete drive chain (mechanical system + motor/controller), the maximum torque of the motor can lie below the upper limit for the mechanical system (M_{mech}) and thus limit the maximum permissible drive torque of the overall drive chain.

If the maximum torque of the motor lies above the upper limit for the mechanical system (M_{mech}), the maximum motor torque must be limited to the permissible value for the mechanical system.

General motor preselection

The motor can be generally preselected using the following conditions.

Condition 1:

The rotary speed of the motor must be greater than or equal to the rotary speed required for the mechanical system (but not exceeding the maximum permissible limit value).

$$n_{max} \geq n_{mech}$$

Condition 2:

Consideration of the ratio of mass moments of inertia of the mechanical system and the motor. The ratio of the mass moments of inertia serves as an indicator for the control performance of a motor-controller combination. The mass moment of inertia of the motor is directly related to the motor size.

Ratio of mass moments of inertia

For preselection, experience has shown that the following ratios will result in high control performance.

These are not rigid limits, but values exceeding them will require closer consideration of the specific application.

Application area	V
Handling	≤ 6.0
Machining	≤ 1.5

$$V = \frac{J_{ex}}{J_m + J_{br}}$$

Condition 3:

Estimation of the ratio of the static load moment to the continuous torque of the motor. The torque ratio must be less than or equal to the empirical value of 0.6. This condition roughly factors in the missing dynamic characteristics of an exact motion profile with the required motor torques.

Torque ratio

$$\frac{M_{stat}}{M_0} \leq 0.6$$

Static load moment

$$M_{stat} = M_R + M_g$$

Linear modules MKK

Weight moment

For vertical installation position only!

For motor attachment via flange and coupling: $i = 1$

$$M_g = \frac{P \cdot (m_{ex} + m_{ca}) \cdot g}{2000 \cdot \pi \cdot i}$$

Linear modules MKR

Weight moment

For vertical installation position only!

$$M_g = \frac{d_3 \cdot (m_{ex} + m_{ca}) \cdot g}{2000 \cdot i}$$

In the chapter "Configuration and ordering," users can put together standard configurations, including motor attachment, gears and motor, for the various linear motion system sizes by selecting the appropriate options. By checking the above conditions, it is possible to see whether a standard motor selected in a particular configuration will generally be of a suitable size for the specific application.

Precise drive sizing

Preselecting the motor according to this rough guide is no substitute for the required precise design calculations for the drive, taking all moments/torques and rotary speed levels into account. For precise calculation of the electric drive, including consideration of the specific motion profile, please refer to the performance data in the catalog "Rexroth drive technology".

When sizing the drive, the maximum permitted values for linear speed, drive torque and acceleration must not be exceeded, in order to avoid damaging the mechanical system.

Calculation example MKK with belt side drive

Given data

In a handling task, a mass of 30 kg is to be moved horizontally by 500 mm at a travel speed of 0.5 m/s. The following was selected based on the technical data and the installation space:

Linear module MKK-080-NN-3

- With sealing strip
- Motor attachment via belt side drive, $i = 1.5$
- with AC servo motor MS2N04-B0BTN with brake

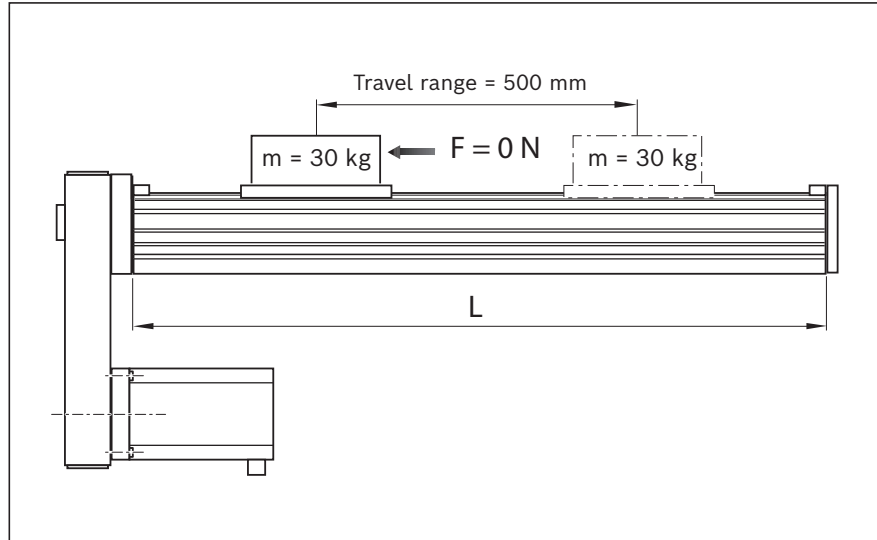

Estimation of length L

(The first estimate assumes a large lead ($P = 20$ mm) and therefore length, since the permissible speed can decrease as length increases. For the excess travel s_e , the value $2 \times P$ is selected).

	L	$= s_{eff} + 2 \cdot s_e + L_{ca} + L_{ad}$
Excess travel:	s_e	$= 2 \cdot P = 2 \cdot 20 = 40$ mm
Max. travel range:	s_{max}	$= s_{eff} + 2 \cdot s_e$ $= 500 + 2 \cdot 40 = 580$ mm
Length:	L	$= 580 + 260 + 109 = 949$ mm

Selection of the ball screw assembly

(Better to choose the lowest lead as this is favorable in terms of resolution, braking distance, length.)

Permissible ball screw assemblies according to the "Permissible speed" graph	
at $v = 0.5$ m/s and $L = 949$ mm:	
KGT 20 x 10 and KGT 20 x 20	
Selected ball screw assembly (lower lead):	
KGT 20 x 10	
maximum permissible speed for KGT 20 x 10 as read from graph:	
$v_{max} = 0.63$ m/s	

Calculation of length L

(for selected KGT)

Excess travel:	s_e	$= 2 \cdot P = 2 \cdot 10 = 20$ mm
Max. travel range:	s_{max}	$= s_{eff} + 2 \cdot s_e$ $= 500 + 2 \cdot 20 = 540$ mm
Length:	L	$= 540 + 260 + 109 = 909$ mm

Friction torque M_R

(motor attachment via belt side drive)

	M_R	$= M_{Rsd} + \frac{M_{Rs}}{i}$
Linear module:	M_{Rs}	$= 0.50$ Nm
Belt side drive:	M_{Rsd}	$= 0.40$ Nm ($i = 1.5$)
Friction torque:	M_R	$= 0.40 + \frac{0.50}{1.5} = 0.73$ Nm

Mass moment of inertia J_{ex}

(motor attachment via belt side drive)

$$J_{ex} = J_{sd} + \frac{(J_s + J_t)}{i^2}$$

Belt side drive: $J_{sd} = 85 \cdot 10^{-6} \text{ kg/m}^2$

Linear module: $J_s = (k_{J \text{ fix}} + k_{J \text{ var}} \cdot L) \cdot 10^{-6} = (16.628 + 0.084 \cdot 909) \cdot 10^{-6}$
 $= 92.984 \cdot 10^{-6} \text{ kg/m}^2$

External load: $J_t = m_{ex} \cdot k_{J \text{ m}} \cdot 10^{-6} = 30 \cdot 2.533 \cdot 10^{-6} = 75.99 \cdot 10^{-6} \text{ kg/m}^2$

Mass moment of inertia: $J_{ex} = 85 \cdot 10^{-6} + \frac{(92.984 \cdot 10^{-6} + 75.99 \cdot 10^{-6})}{1.5^2}$
 $= 160.1 \cdot 10^{-6} \text{ kg/m}^2$

Maximum permissible rotary speed n_{mech}

(motor attachment via belt side drive)
 Limit for mechanical system

$$n_{mech} = \frac{(v_{mech} \cdot i \cdot 1000 \cdot 60)}{P}$$

Max. permissible speed: $v_{mech} = v_{max} = 0.63 \text{ m/s}$

Max. permissible rotary speed: $n_{mech} = \frac{(0.63 \cdot 1.5 \cdot 1000 \cdot 60)}{10} = 5 \text{ 670 rpm}$

Maximum rotary speed of application n_{mech}

(motor attachment via belt side drive)
 Application tolerance

Speed: $v_{mech} = 0.5 \text{ m/s}$

Rotary speed: $n_{mech} = \frac{0.5 \cdot 1.5 \cdot 1000 \cdot 60}{10} = 4500 \text{ rpm}$

Maximum permissible drive torque M_{mech}

(motor attachment via belt side drive)
 Limit for mechanical system

$$M_{mech} = \text{Minimum} \left(M_{sd}; \frac{M_p}{i} \right)$$

Belt side drive: $M_{sd} = 5.0 \text{ Nm}$ (gear ratio $i = 1.5$ for MS2N-04)

Linear module: $M_p = 9.8 \text{ Nm}$

Drive torque: $M_{mech} = \text{Minimum} \left(5.0; \frac{9.8}{1.5} \right)$
 $= \text{Minimum} \left(5.0; 6.53 \right) = 5.0 \text{ Nm}$

Calculation example MKK with belt side drive (continued)

Motor preselection check

Selected motor:
MS2N04-B0BTN with brake

Condition 1:

$$\begin{aligned} \text{Rotary speed: } n_{\max} &\geq n_{\text{mech}} \\ 6,000 &\geq 4500 \text{ condition met - motor selection OK} \end{aligned}$$

Condition 2:

$$\begin{aligned} \text{Mass moment of inertia ratio: } V &= \frac{J_{\text{ex}}}{J_{\text{m}} + J_{\text{br}}} \\ \text{Motor inertia: } J_{\text{m}} &= 70.0 \cdot 10^{-6} \text{ kg/m}^2 \\ \text{Brake moment of inertia: } J_{\text{br}} &= 40 \cdot 10^{-6} \text{ kg/m}^2 \\ \text{Moment of inertia ratio: } V &= \frac{160.1 \cdot 10^{-6}}{(70 \cdot 10^{-6} + 40 \cdot 10^{-6})} \\ &= 1.46 \\ \text{Handling condition: } V &\leq 6 \\ 1.46 &\leq 6 \text{ condition met - motor selection OK} \end{aligned}$$

Condition 3:

$$\begin{aligned} \text{Torque ratio: } \frac{M_{\text{stat}}}{M_0} &\leq 0.6 \\ \text{Static load moment: } M_{\text{stat}} &= M_{\text{R}} + M_{\text{g}} \text{ (installed horizontally } M_{\text{g}} = 0) \\ &= 0.73 \text{ Nm} \\ \text{Continuous motor torque: } M_0 &= 1.75 \text{ Nm} \\ \text{Torque ratio: } \frac{0.73}{1.75} &= 0.42 \\ 0.42 &\leq 0.6 \text{ condition met - motor selection OK} \end{aligned}$$

Result

Linear module MKK-080-NN-3

$L = 909 \text{ mm}$, $s_{\max} = 540 \text{ mm}$, $L_{\text{ca}} = 260 \text{ mm}$; BASA: $d_0 = 20 \text{ mm}$, $P = 10 \text{ mm}$; with corrosion-resistant sealing strip; gear ratio $i = 1.5$

Motor preselection: MS2N04-B0BTN with brake

For precise sizing of the electric drive, the motor-controller combination must always be considered, as the performance data (e.g. maximum useful speed and maximum torque) will depend on the controller used.

When doing this, the following data must be considered:

$$\begin{aligned} \text{Friction torque: } M_{\text{R}} &= 0.73 \text{ Nm} \\ \text{Mass moment of inertia: } J_{\text{ex}} &= 160.1 \cdot 10^{-6} \text{ kg/m}^2 \\ \text{Speed: } v_{\text{mech}} &= 0.5 \text{ m/s } (n_{\text{mech}} = 4,500 \text{ rpm}) \\ \text{Drive torque limit: } M_{\text{mech}} &= 5.0 \text{ Nm} \rightarrow \text{The motor torque must be limited to 5.0 Nm on the drive side!} \\ \text{Acceleration limit: } a_{\max} &= 50 \text{ m/s}^2 \\ \text{Limit for speed: } v_{\max} &= 0.63 \text{ m/s } (n_{\text{mech}} = 5,670 \text{ rpm}) \end{aligned}$$

Besides the preferred type MS2N04-B0BTN, other motors with identical connection dimensions can be adapted while taking care not to exceed the calculated limit values.

Calculation example MKR with gear reducer

Given data

In a handling task, a mass of 25 kg is to be moved horizontally by 1800 mm at a travel speed of 1.5 m/s. The following was selected based on the technical data and the installation space:

Linear module MKR-080-NN-3

- Carriage length = 260 mm
- Motor attachment via gear reducer, $i = 5$
- Max. permissible speed = 3 m/s ($i = 5$)
- with AC servo motor MS2N05-COBTN with brake

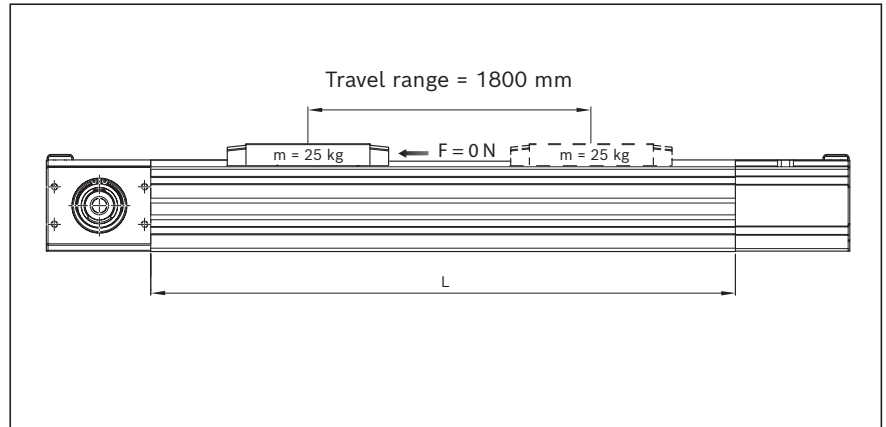

Calculation of length L

(In most cases, 2x feed constant is sufficient as general guideline value for excess travel. The excess travel must be greater than the emergency stop stopping distance, which is calculated for exact sizing of the electrical drive.)

$$\begin{aligned}
 L &= s_{\max} + L_{ca} + L_{ad} \\
 \text{Feed constant: } u &= \frac{u(i=1)}{i} \\
 &= \frac{205}{5} = 41 \text{ mm} \\
 \text{Excess travel: } s_e &= 2 \cdot u = 2 \cdot 41 = 82 \text{ mm} \\
 \text{Max. travel range: } s_{\max} &= s_{\text{eff}} + 2 \cdot s_e \\
 &= 1,800 + 2 \cdot 82 = 1,964 \text{ mm} \\
 \text{Length: } L &= 1,964 + 260 + 17 = 2,241 \text{ mm}
 \end{aligned}$$

Friction torque M_R

$$\begin{aligned}
 M_R &= M_{Rge} + \frac{M_{RS}}{i} \\
 \text{Linear module: } M_{RS} &= 2.0 \text{ Nm} \\
 \text{Gear: } M_{Rge} &= 0.5 \text{ Nm} \\
 \text{Friction torque: } M_R &= 0.5 + \frac{2.0}{5} = 0.9 \text{ Nm}
 \end{aligned}$$

Mass moment of inertia J_{ex}

$$\begin{aligned}
 J_{ex} &= J_{ge} + \frac{(J_s + J_t)}{i^2} \\
 \text{Linear module: } J_s &= (k_{J \text{ fix}} + k_{J \text{ var}} \cdot L) \cdot 10^{-6} \\
 &= (3,197 + 0.3188 \cdot 2,241) \cdot 10^{-6} \\
 &= 3,911.43 \cdot 10^{-6} \text{ kg/m}^2 \\
 \text{External load: } J_t &= m_{ex} \cdot k_{J \text{ m}} \cdot 10^{-6} \\
 &= 25 \cdot 1,065 \cdot 10^{-6} \\
 &= 26,625 \cdot 10^{-6} \text{ kg/m}^2 \\
 \text{Mass moment of inertia: } J_{ex} &= 129 \cdot 10^{-6} + \frac{(3,911.43 \cdot 10^{-6} + 26,625 \cdot 10^{-6})}{5^2} \\
 &= 1,350.457 \cdot 10^{-6} \text{ kg/m}^2
 \end{aligned}$$

Calculation example MKR with gear reducer (continued)

Maximum permissible rotary speed n_{mech}

(Motor attachment via gear reducer, without considering the motor)
Limit for mechanical system

	$n_{\text{mech}} = \text{Minimum } (n_p \cdot i ; n_{\text{ge}})$
Linear module:	$n_p = \frac{v_{\text{max}} \cdot 1,000 \cdot 60}{\pi \cdot d_3}$ $= \frac{3 \cdot 1,000 \cdot 60}{\pi \cdot 65.27}$ $= 878 \text{ rpm}$
Gear:	$n_{\text{ge}} = 7,000 \text{ rpm}$
Max. permissible rotary speed:	$n_{\text{mech}} = \text{Minimum } (878 \cdot 5 ; 7,000)$ $= \text{Minimum } (4,390 ; 7,000)$ $= 4,390 \text{ rpm}$

Maximum permissible speed v_{mech}

(Motor attachment via gear reducer, without considering the motor)
Limit for mechanical system

	$v_{\text{mech}} = \frac{n_{\text{mech}} \cdot \pi \cdot d_3}{i \cdot 1000 \cdot 60}$
Max. permissible speed:	$v_{\text{mech}} = \frac{4,390 \cdot \pi \cdot 65.27}{5 \cdot 1,000 \cdot 60}$ $= 3.0 \text{ m/s}$

Maximum permitted rotary speed of the application n_{mech}

(Motor attachment via gear reducer, without considering the motor)
Application tolerance

Speed:	$v_{\text{mech}} = 1.5 \text{ m/s}$
Rotary speed:	$n_{\text{mech}} = \frac{v_{\text{mech}} \cdot i \cdot 1,000 \cdot 60}{\pi \cdot d_3}$ $n_{\text{mech}} = \frac{1.5 \cdot 5 \cdot 1,000 \cdot 60}{\pi \cdot 65.27}$ $= 2,194 \text{ rpm}$

Maximum permissible drive torque M_{mech}

(Motor attachment via gear reducer, without considering the motor)
Limit for mechanical system

	$M_{\text{mech}} = \text{Minimum } \left(\frac{M_{\text{ge}}}{i} ; \frac{M_p}{i} \right)$
Linear module:	$M_p = 36 \text{ Nm}$
Gear:	$M_{\text{ge}} = 176 \text{ Nm}$
Drive torque:	$M_{\text{mech}} = \text{Minimum } \left(\frac{176}{5} ; \frac{36}{5} \right)$ $= \text{Minimum } (35.2 ; 7.2)$ $= 7.2 \text{ Nm}$

Motor preselection check

Selected motor:
MS2N05-COBTN with brake

Condition 1:

$$\begin{aligned} \text{Rotary speed: } n_{\max} &\geq n_{\text{mech}} \\ 6,000 &\geq 2194 \text{ condition met - motor selection OK} \end{aligned}$$

Condition 2:

$$\begin{aligned} \text{Mass moment of inertia ratio: } V &= \frac{J_{\text{ex}}}{J_{\text{m}} + J_{\text{br}}} \\ \text{Motor inertia: } J_{\text{m}} &= 290 \cdot 10^{-6} \text{ kg/m}^2 \\ \text{Brake moment of inertia: } J_{\text{br}} &= 110 \cdot 10^{-6} \text{ kg/m}^2 \\ \text{Moment of inertia ratio: } V &= \frac{1350.457 \cdot 10^{-6}}{400 \cdot 10^{-6}} \\ &= 3.38 \\ \text{Handling condition: } V &\leq 6 \\ 3.38 &\leq 6 \text{ condition met - motor selection OK} \end{aligned}$$

Condition 3:

$$\begin{aligned} \text{Torque ratio: } \frac{M_{\text{stat}}}{M_0} &\leq 0.6 \\ \text{Static load moment: } M_{\text{stat}} &= M_{\text{R}} + M_{\text{g}} \text{ (installed horizontally } M_{\text{g}} = 0) \\ &= 0.9 \text{ Nm} \\ \text{Continuous torque} \\ \text{of the motor: } M_0 &= 6.1 \text{ Nm} \\ \text{Torque ratio: } \frac{0.9}{6.1} &= 0.15 \\ 0.15 &\leq 0.6 \text{ condition met - motor selection OK} \end{aligned}$$

All three conditions met ⇒ Selected motor is suitable for the application.

Result**Linear module MKR-080-NN-3**

$L = 2241 \text{ mm}$, $s_{\max} = 1964 \text{ mm}$, $L_{\text{ca}} = 260 \text{ mm}$, toothed belt drive, motor attachment via planetary gear, gear ratio $i = 5$

Motor preselection: MS2N05-COBTN with brake

For precise sizing of the electric drive, the motor-controller combination must always be considered, as the performance data (for example, maximum useful speed and maximum torque) will depend on the controller used. When doing this, the following data must be considered.

$$\begin{aligned} \text{Friction torque } M_{\text{R}} &= 0.9 \text{ Nm} \\ \text{Mass moment of inertia } J_{\text{ex}} &= 1,350.457 \cdot 10^{-6} \text{ kg/m}^2 \\ \text{Travel speed } v_{\text{mech}} &= 1.5 \text{ m/s } (n_{\text{mech}} = 2,194 \text{ rpm}) \\ \text{Drive torque limit } M_{\text{mech}} &= 7.2 \text{ Nm} \end{aligned}$$

⇒ The motor torque must be limited to 7.2 Nm on the drive side!

$$\begin{aligned} \text{Acceleration limit } a_{\max} &= 50 \text{ m/s}^2 \\ \text{Limit for travel speed } v_{\max} &= 3.0 \text{ m/s } (n_{\text{mech}} = 4,390 \text{ rpm}) \end{aligned}$$

After determining the emergency-stop stopping distance during precise sizing, the selected excess travel must be checked to see whether it is sufficient and adjusted if necessary.

Besides the preferred type MS2N05-COBTN, other motors with identical connection dimension can be adapted while taking care not to exceed the calculated limits.

Abbreviations

Abbreviations

Abbreviation/ Index	Designation	Unit
a	Acceleration	(m/s ²)
a_{max}	Maximum acceleration rate	(m/s ²)
BASA	Ball screw assembly	(–)
B_t	Belt type	(–)
c_{spe}	Specific spring rate	(N)
C_{gw}	Dynamic load capacity, guideway	(N)
C_{bs}	Dynamic load capacity, ball screw assembly	(N)
C_{fb}	Dynamic load capacity, fixed bearing	(N)
d₀	Nominal diameter, ball screw assembly	(mm)
d₃	Belt pulley diameter	(mm)
f_w	Load factor	(–)
F_n	Axial load of the ball screw assembly	(N)
F_{eff}	Effective equivalent axial load	(N)
F_{bp}	Max. belt drive transmission force	(N)
F_{comb}	Combined equivalent bearing load	(N)
F_{mbs}	Dynamically equivalent load on bearing of the ball screw assembly	(N)
F_{mgw}	Dynamically equivalent load on bearing of the guideway	(N)
F_n	Axial load of the ball screw assembly	(N)
F_{t perm}	Belt elasticity limit	(N)
F_y	Load due to a resulting force in the y-direction	(N)
F_{y max}	Maximum dynamic load in y-direction	(N)
F_z	Load due to a resulting force in the z-direction	(N)
F_{z max}	Maximum dynamic load in z-direction	(N)
g	Gravitational acceleration (= 9.81)	(m/s ²)
i	Gear ratio	(–)
I_y	Planar moment of inertia about the y-axis	(cm ⁴)
I_z	Planar moment of inertia about the z-axis	(cm ⁴)
J_{br}	Mass moment of inertia of the motor brake	(kg/m ²)
J_c	Mass moment of inertia of the coupling	(kg/m ²)
J_{dc}	Mass moment of inertia of the drive train	(kg/m ²)
J_{ex}	Mass moment of inertia of the mechanical system	(kg/m ²)
J_{ge}	Mass moment of inertia of the gear about the motor journal	(kg/m ²)
J_m	Mass moment of inertia of the motor	(kg/m ²)
J_s	Mass moment of inertia of the linear motion system	(kg/m ²)
J_{sd}	Mass moment of inertia of the belt side drive about the motor journal	(kg/m ²)
J_t	Translative mass moment of inertia of external load based on the linear motion system screw journal	(kg/m ²)
k_{g fix}	Constant for fixed portion of mass	(kg)

Abbreviation/ Index	Designation	Unit
k_{g var}	Constant for variable-length portion of mass	(kg/mm)
k_{J fix}	Constant for fixed portion of mass moment of inertia	(kg/mm ²)
k_{J m}	Constant for mass-specific portion of mass moment of inertia	(mm ²)
k_{J var}	Constant for variable-length portion of mass moment of inertia	(kg/mm)
L	Length of the linear motion system	(mm)
L_{ad}	Additional length	(mm)
L_c	Length nut/length nut and housing	(mm)
L_{ca}	Carriage length	(mm)
L_{bs}	Nominal service life (Ball screw assembly, fixed bearing)	(rpm)
L_{hbs}	Nominal service life (Ball screw assembly, fixed bearing)	(h)
L_{gw}	Nominal service life of the guideway	(m)
L_{hgw}	Nominal service life of the guideway	(h)
L_w	Centerline-to-centerline distance between carriages	(mm)
m_{br}	Holding brake mass	(kg)
m_{ca}	Moved mass of system of carriage	(kg)
m_{ex}	Moved external load	(kg)
m_{fc}	Mass of flange and coupling	(kg)
m_m	Mass of the motor	(kg)
m_s	Mass of the linear system (without attachments)	(kg)
m_{sd}	Mass of the timing belt side drive	(kg)
M₀	Continuous motor torque	(Nm)
M_{cN}	Rated torque of coupling	(Nm)
M_g	Weight moment at motor journal	(Nm)
M_{ge}	Maximum permissible acceleration torque of the gear (at the output drive)	(Nm)
M_L	Dynamic longitudinal moment load capacity	(Nm)
M_m	Equivalent dynamic torque	(Nm)
M_{max}	Max. possible motor torque	(Nm)
M_{mech}	Maximum permissible drive torque for mechanical system	(Nm)
M_p	Maximum permissible drive torque (at drive journal)	(Nm)
M_R	Frictional torque at motor journal	(Nm)
M_{Rge}	Friction torque of gear at motor journal	(Nm)
M_{Rs}	Friction torque of system	(Nm)
M_{Rsd}	Friction torque of belt side drive at motor journal	(Nm)
M_{sd}	Maximum permissible drive torque of the belt side drive	(Nm)
M_{stat}	Static load moment	(Nm)
M_t	Dynamic torsional moment load capacity	(Nm)
M_x	Dynamic torsional moment around the x-axis	(Nm)

Abbreviation/ Index	Designation	Unit
$M_{x \max}$	Maximum permissible torsional moment around the x-axis	(Nm)
M_y	Dynamic torsional moment around the y-axis	(Nm)
$M_{y \max}$	Maximum permissible torsional moment around the y-axis	(Nm)
M_z	Dynamic torsional moment around the z-axis	(Nm)
$M_{z \max}$	Maximum permissible torsional moment around the z-axis	(Nm)
n	Rotary speed of the ball screw assembly	(rpm)
n_1, n_2, \dots, n_n	Rotary speed in acceleration and braking phases	(rpm)
$n_{A1 \dots n}$	Starting speed in phase 1 ... n	(rpm)
$n_{E1 \dots n}$	Ending speed in phase 1 ... n	(rpm)
n_{ge}	Maximum permissible rotary speed of the gear	(rpm)
n_m	Average rotary speed of the ball screw assembly	(rpm)
n_{mech}	Maximum permissible rotary speed for mechanical system	(rpm)
n_{max}	Max. motor speed	(rpm)
n_p	Maximum permissible rotary speed of the linear motion system	(rpm)
P	Screw lead/ball screw assembly	(mm)
P_{app}	Effective power in application	(W)
Keyway	Keyway	(-)
$q_{t1..n}$	Time step of the phases	(%)
s_a	Acceleration travel	(mm)
s_e	Excess travel	(mm)
s_{eff}	Effective stroke	(mm)
s_{min}	Minimum travel range	(mm)
s_{max}	Maximum travel	(mm)
SPU	Screw support	(-)
TT	Carriage	(-)
t_a	Acceleration/braking time	(s)
t_1, t_2, \dots, t_n	Time for phase 1 ... n	(s)
t_{ges}	Sum of time steps	(s)
u	Feed constant	(mm/ rev)
v_1, v_2, \dots, v_n	Speed in phase 1 ... n	(m/s)
v_{max}	Maximum permissible speed	(m/s)
v_{mech}	Maximum permissible speed of mechanical system	(m/s)
v_{mgw}	Average linear speed of the guideway	(m/s)
V	Ratio of mass moments of inertia of drive chain and motor	(-)
z_1	Application point of the effective force	(mm)
π	Pi	(-)

Ordering example MKK-080-NN-3

Ordering example MKK-080-NN-3

Ordering data		Explanation
Linear module	MKK-080-NN-3	Linear module MKK-080-NN-3
Travel range max. (s_{max})	2,800	–
Material pairing	ALST	Aluminum/steel strip
Lubrication	LSS	Lubrication version LSS
Length measuring system	000	Without length measuring system
Carriage		
Carriage fastening	T	Carriage with thread
Number of carriages	1	One carriage
Carriage centerline-to-centerline distance L_w ¹⁾	–	–
Guideway	004	Ball guide rail / frame with centering holes
Drive		
Keyway	0	Without keyway
BASA (Rexroth ball screw assembly do x P)	20x10	Nominal diameter = 20 mm, lead = 10 mm
Accuracy class	T7	T7 = lead deviation 53µm/300mm
Screw support	002	2 Screw support (SPU)
Version	F001	With flange and coupling
Mounting interface		
Gear ratio	i = 1	Gear ratio i = 1
Mechanical interface	MS2N04	Motor attachment for servo motor MS2N04
Motor		
Motor code	MS2N04-D0BQN	Motor type
Motor connection	1	Motor connection (1 cable)
Motor holding brake	Y	With holding brake
Motor connector position	180	Motor connector position = 180°
Cover		
Cover version	2	With cover (corrosion resistant steel strip)
Cover with side sealing	0	Without side sealing
Sensor system (available with max. 6 switches)		
Sensor 1	120	PNP NC
Sensor 2	120	PNP NC
Automation package		
Commissioning & process support	000	without software
Drive controller	302	IndraDrive Cs Converter HCS01-W0018 Interface: Multi-Ethernet + integrated safety technology (STO -> Safe Torque Off)
Motor cable	105	Length of the cable 5 m
Documentation	001	Standard report

¹⁾ Only required for two carriages

Further information

Further information

Notes

Bosch Rexroth AG

Ernst-Sachs-Straße 100
97424 Schweinfurt, Germany
www.boschrexroth.com

Find your local contact person here:

www.boschrexroth.com/contact

