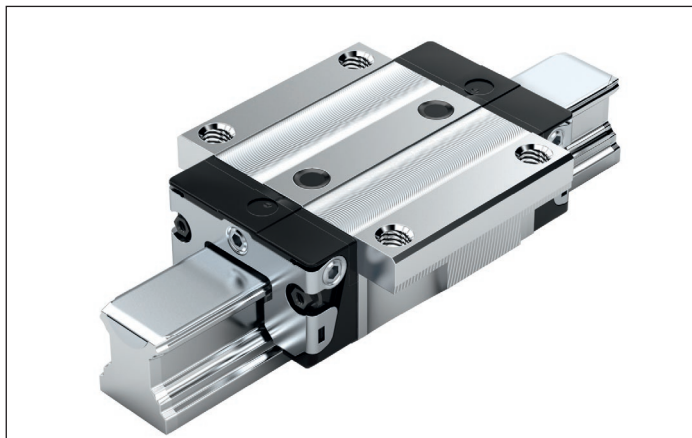

FNS – Flanged, normal, standard height R1651 ... 2.

**Dynamic characteristics**Travel speed: $v_{\max} = 5 \text{ m/s}$ Acceleration: $a_{\max} = 500 \text{ m/s}^2$ (If $F_{\text{comb}} > 2.8 \cdot F_{\text{pr}}$: $a_{\max} = 50 \text{ m/s}^2$)**Note on lubrication**

► Pre-lubricated

Note

Can be used on all SNS/SNO ball guide rails. Ball runner blocks of size 55 and size 65 can be found in chapter “Heavy-duty ball runner block BSHP made of steel” after this chapter.

Options and material numbers

Size	Ball runner blocks with size	Preload class				Accuracy class						Seals on ball runner blocks						
		C0	C1	C2	C3	N	H	P	XP	SP	UP	without ball chain			with ball chain			
												SS	LS ¹⁾	DS	SS	LS ¹⁾	DS	
15	R1651 1	9				4	3	–	–	–	–	20	21	–	22	23	–	–
			1			4	3	2	8	1	9	20	21	2Z	22	23	2Y	–
				2		–	3	2	8	1	9	20	21	2Z	22	23	2Y	–
					3	–	–	–	8	1	9	20	21	2Z	22	23	2Y	–
20	R1651 8	9				4	3	–	–	–	–	20	21	–	22	23	–	–
			1			4	3	2	8	1	9	20	21	2Z	22	23	2Y	–
				2		–	3	2	8	1	9	20	21	2Z	22	23	2Y	–
					3	–	–	–	8	1	9	20	21	2Z	22	23	2Y	–
25	R1651 2	9				4	3	–	–	–	–	20	21	–	22	23	–	–
			1			4	3	2	8	1	9	20	21	2Z	22	23	2Y	–
				2		–	3	2	8	1	9	20	21	2Z	22	23	2Y	–
					3	–	–	–	8	1	9	20	21	2Z	22	23	2Y	–
30	R1651 7	9				4	3	–	–	–	–	20	21	–	22	23	–	–
			1			4	3	2	8	1	9	20	21	2Z	22	23	2Y	–
				2		–	3	2	8	1	9	20	21	2Z	22	23	2Y	–
					3	–	–	–	8	1	9	20	21	2Z	22	23	2Y	–
35	R1651 3	9				4	3	–	–	–	–	20	21	–	22	23	–	–
			1			4	3	2	8	1	9	20	21	2Z	22	23	2Y	–
				2		–	3	2	8	1	9	20	21	2Z	22	23	2Y	–
					3	–	–	–	8	1	9	20	21	2Z	22	23	2Y	–
45	R1651 4	9				4	3	–	–	–	–	20	–	–	22	–	–	–
			1			4	3	2	8	1	9	20	–	2Z	22	–	2Y	–
				2		–	3	2	8	1	9	20	–	2Z	22	–	2Y	–
					3	–	–	–	8	1	9	20	–	2Z	22	–	2Y	–
E.g.:	R1651 7		1				3								20			

1) Only for accuracy classes N and H and for XP in preload class C1.

Order example

Options:

- Ball runner blocks FNS
- Size 30
- Preload class C1
- Accuracy class H
- With standard seal, without ball chain

Material number:

R1651 713 20

Preload classes

C0 = Without preload (clearance)
 C1 = Moderate preload
 C2 = Average preload
 C3 = High preload

Seals

SS = Standard seal
 LS = Low-friction seal
 DS = Double-lip seal

Key

gray numbers
 = No preferred variant / combination
 (partially longer delivery times)

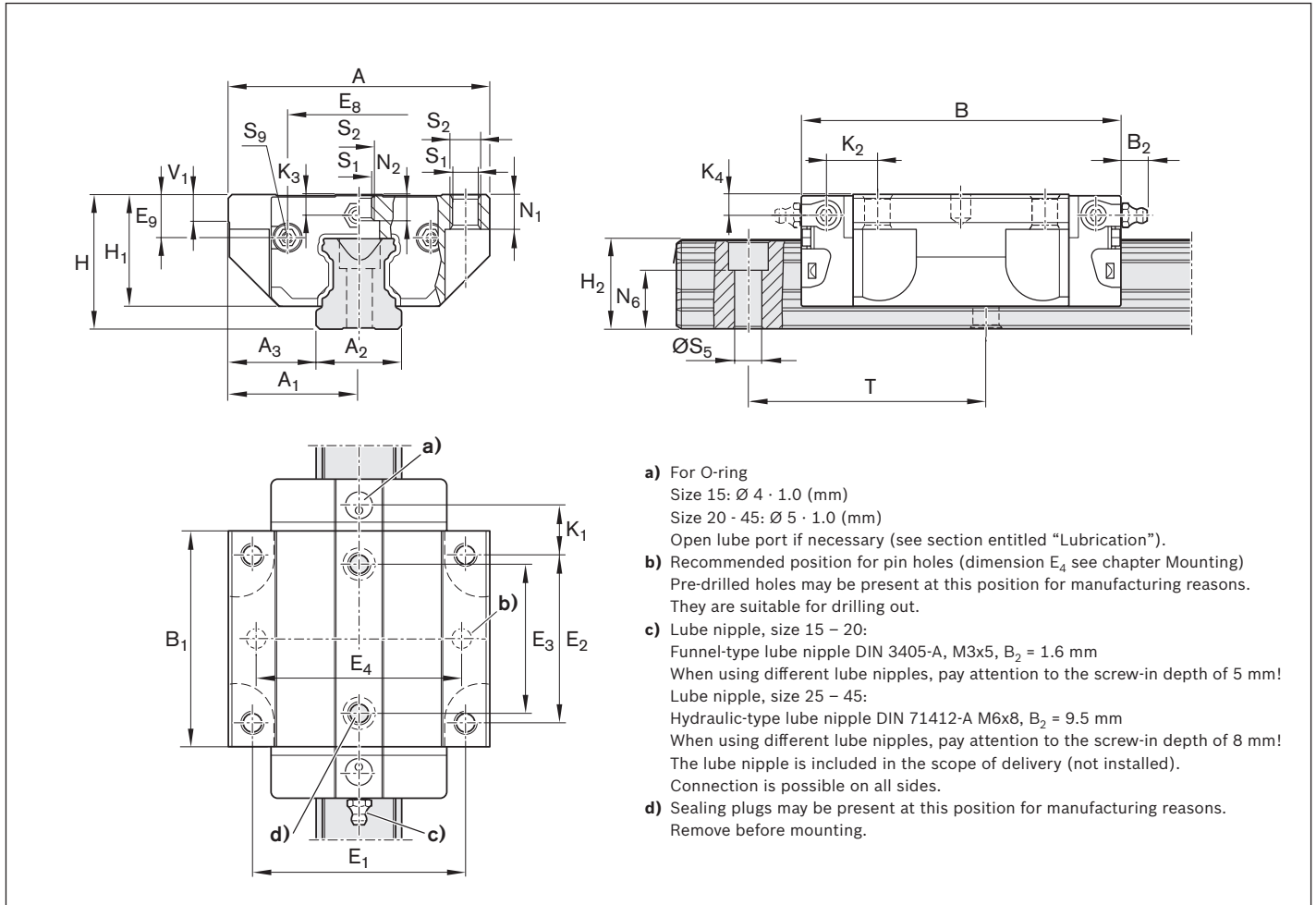

- a) For O-ring
 Size 15: Ø 4 · 1.0 (mm)
 Size 20 - 45: Ø 5 · 1.0 (mm)
 Open lube port if necessary (see section entitled "Lubrication").
- b) Recommended position for pin holes (dimension E₄ see chapter Mounting)
 Pre-drilled holes may be present at this position for manufacturing reasons.
 They are suitable for drilling out.
- c) Lube nipple, size 15 – 20:
 Funnel-type lube nipple DIN 3405-A, M3x5, B₂ = 1.6 mm
 When using different lube nipples, pay attention to the screw-in depth of 5 mm!
 Lube nipple, size 25 – 45:
 Hydraulic-type lube nipple DIN 71412-A M6x8, B₂ = 9.5 mm
 When using different lube nipples, pay attention to the screw-in depth of 8 mm!
 The lube nipple is included in the scope of delivery (not installed).
 Connection is possible on all sides.
- d) Sealing plugs may be present at this position for manufacturing reasons.
 Remove before mounting.

Size	Dimensions (mm)																		
	A	A ₁	A ₂	A ₃	B ^{+0.5}	B ₁	E ₁	E ₂	E ₃	E ₈	E ₉	H	H ₁	H ₂ ¹⁾	H ₂ ²⁾	K ₁	K ₂	K ₃	K ₄
15	47	23.5	15	16.0	58.2	39.2	38	30	26	24.55	6.70	24	19.90	16.30	16.20	8.00	9.6	3.20	3.20
20	63	31.5	20	21.5	75.0	49.6	53	40	35	32.50	7.30	30	25.35	20.75	20.55	11.80	11.8	3.35	3.35
25	70	35.0	23	23.5	86.2	57.8	57	45	40	38.30	11.50	36	29.90	24.45	24.25	12.45	13.6	5.50	5.50
30	90	45.0	28	31.0	97.7	67.4	72	52	44	48.40	14.60	42	35.35	28.55	28.35	14.00	15.7	6.05	6.05
35	100	50.0	34	33.0	110.5	77.0	82	62	52	58.00	17.35	48	40.40	32.15	31.85	14.50	16.0	6.90	6.90
45	120	60.0	45	37.5	137.6	97.0	100	80	60	69.80	20.90	60	50.30	40.15	39.85	17.30	19.3	8.20	8.20

Size	Dimensions (mm)										Mass (kg)	Load capacities ³⁾ (N)		Load moments ³⁾ (Nm)			
	N ₁	N ₂	N ₆ ^{+0.5}	S ₁	S ₂	S ₅	S ₉	T	V ₁	m		C	C ₀	M _t	M _{t0}	M _L	M _{L0}
15	5.2	4.40	10.3	4.3	M5	4.5	M2.5x3.5	60	5.0	0.20	9860	12700	95	120	68	87	
20	7.7	5.20	13.2	5.3	M6	6.0	M3x5	60	6.0	0.45	23400	29800	300	380	200	260	
25	9.3	7.00	15.2	6.7	M8	7.0	M3x5	60	7.5	0.65	28600	35900	410	510	290	360	
30	11.0	7.90	17.0	8.5	M10	9.0	M3x5	80	7.0	1.10	36500	48100	630	830	440	580	
35	12.0	10.15	20.5	8.5	M10	9.0	M3x5	80	8.0	1.60	51800	80900	1110	1740	720	1130	
45	15.0	12.40	23.5	10.4	M12	14.0	M4x7	105	10.0	3.00	86400	132000	2330	3560	1540	2350	

- 1) Dimension H₂ with cover strip
- 2) Dimension H₂ without cover strip
- 3) Load ratings and load moments for ball runner block **without** ball chain. Load ratings and load moments for ball runner block **with** ball chain 12

Determination of the dynamic load capacities and load moments is based on a stroke travel of 100,000 m according to DIN ISO 14728-1. Often only 50,000 m are actually stipulated. For comparison: Multiply the values **C**, **M_t** and **M_L** by 1.26 according to the table.